

SMITH COLLEGE

W 2012 Women in Science

Clark Science Center's
Summer Research Fellows Program



INTRODUCTION

“I don’t know.” This is a statement that can be easily misunderstood if a person is not familiar with how a scientist conducts her work. As scientists, we are the experts...right? Many assume that with all the facts scientists generate, they should have ready, definitive explanations in response to most questions. Emerging from a misunderstanding of what science is, or isn’t, a lively debate is underway about the role of science in national decision and policy making. For young scientists graduating into the national landscape where the role of science may be questioned, the world has become considerably more complicated. And they need to be ready for it.

Preparing our science majors for the world they will be entering is fundamental to our science and engineering education philosophy. Student-faculty research collaborations are at the center of this ongoing effort. These collaborations provide direct exposure to what science is about: successful and failed experiments, clear and ambiguous results, moving forward and starting over. Our student researchers quickly realize they are on a path of discovery. While textbooks provide important factual foundations, Smith students soon learn that the biological and physical worlds are also characterized by countless unanswered questions. Combined with excellence in classroom teaching, our students learn science by doing science. Through this educational process, we work to foster the confidence reflected in their declaring, “I don’t know, but I’m determined to find out.”

The summer of 2012 saw the number of students seeking summer research experiences with a faculty mentor reaching record levels. In total, 179 students participated in the Summer Undergraduate Research Fellows (SURF) program, involving 59 faculty mentor-advisors, representing all of the Clark Science Center’s fourteen departments and programs. The richness of this program and the collaborations which fuel it are best stated by one of our young scientists:

In parallel we worked on course material that could help students who will take the class. It was probably not supposed to be that much fun, but that is what always happens when scientists connect with their research and see what they do not only as a job, but as a way to make a difference.

— Lucy Chikwetu

Student-faculty research projects knew no geographical bounds. Studies were conducted as locally as the Smith Botanic Garden and MacLeish Field Station, and as distantly as international research sites in Africa, Latin America, South America and Asia. Research topics covered an extraordinarily diverse array of questions. Topics covered the smallest of structures from DNA and protein molecules, to large structures such as the coastline of Chile, to the largest of structures, a galaxy cluster.

Our ability to extend this level of student support is the direct result of our partnerships with public and private institutions, involving 39 funding sources, which provided both funding and encouragement. This broad-based support of Smith College’s Summer Undergraduate Research Fellows Program also represents a record number of contributing partners. With their generous support, we are able to create an overarching atmosphere of collaboration, learning and research, and a community of students and mentors working with a common purpose.



We are pleased to recognize the generous contributors to this year's Summer Undergraduate Research Fellows (SURF) program and extend our deep appreciation to them.

Center for the Environment and Ecological Design and Sustainability (CEEDS)
American Chemical Society Fellowship
American Chemical Society Petroleum Research Fund
Arnold and Mabel Beckman Foundation
B. Elizabeth Horner Fund in the Biological Sciences
Botanic Gardens & Friends
Botanic Gardens SEP
Botanic Gardens /CEEDS
Blakeslee Fund in the Biological Sciences
Committee on Faculty Compensation and Development (CFCD)
Danforth (Botanic Gardens)
Dr. Marianne Tsuk Schiffer A.M. 1958 and Dr. John P. Schiffer Endowed Fund
Facilities (Synthetic Turf Project)/Botanic Gardens
Frances Baker Holmes Fund
Henry Dreyfus Teacher Scholar Award
Howard Hughes Medical Institute
Smith College Botanical Garden Landscape Studies
Margaret Walsh Grantham Fund
Moore Grant, Andrew Guswa
Nancy Kay Holmes Fund
National Grid
National Institutes of Health
National Science Foundation
Provost's Office Funding
S. D. Bechtel Fund
Schultz Foundation
Stephen Bechtel Fund
Susan M. Rambo Fund in Mathematics
Wilens Fund in the Biological Sciences

For further information, please contact:

Thomas S. Litwin, Ph.D.
Director, Clark Science Center
tlitwin@smith.edu



Table of Research Topics

Astronomy

Name	Advisors	Project Title	
Wanda Feng	Suzan Edwards	Mass Accretion and Ejection from T Tauri Stars	1
Isabel Lipartito	James Lowenthal	Confirming a High-Redshift Galaxy Cluster	2
Jenny Podel	Suzan Edwards	Discovering Accretion Properties in Young Stars	3

Biochemistry

Name	Advisors	Project Title	
Minhee Kim, Jinglin Huang and Jing Zhang	Kate Queeney and Rob Dorit	Effects of Surface Chemistry on Biofilm Colonization	4
Katharine von Herrmann	Stylios Scordilis	Proteome Profiling of Development in C2C12 Cells	5
Chelby Wakefield	Stylios Scordilis	Two-dimensional Analysis of C2C12 Muscle Cell Line Development	7

Biological Sciences

Name	Advisors	Project Title	
Jessica Andrade	Laura Katz	Analyses of the Relationship between Location and Microbial Community Diversity	8
Abigail Antoine and Jin Sook Park	Michael Barresi	Function of Slit and Robo in Axon Guidance	10
Emily Barbour	Michael Marcotrigiano	Developing Forms and Maps for Data Collection for the Botanic Garden	12
Kate Brien	Laura Katz	The Spatial Distribution of Planktonic Ciliates off the Coast of Rhode Island	13
Diane Chen	Virginia Hayssen	Smith College's Bird Collection: Accession & History	14
Meredith Gallogly and Stephanie Acevedo	Jesse Bellemare and L. David Smith	Soil Seed Bank Exploration: Comparing Secondary Hemlock, Old Growth Hemlock and Black Birch Forests	16



Biological Sciences *(continued)*

Name	Advisors	Project Title	
Adelaide Gordon	Laura Katz	The Diversity and Ecology of Testate Amoebae in Bogs and Fens	18
Seneca Gray	Reid Bertone-Johnson	Landscape Field Studies	20
Hailun Li	Stylios Scordilis	Creatine Kinase during Muscle Development	21
Carmen M. Hernández	Laura Katz	Examining Diversity of <i>Chilodonella uncinata</i> in a Spatial and Temporal Context	23
Brittany Innis	Gary Hartwell and Gaby Immerman	Mill River Invasive Species Mitigation	25
Jenny Jiang	Steve Williams	Investigation of Immunogenicity Using Immune-Informatics Software	26
Rachel Kaminsky	Robert Merritt, Laura Katz, Robert Newton and Steven Williams	Exploring the Diversity of Sulfate-Reducing Bacteria Diversity in the Avery Brook Beaver Pond Sediments	27
Djéné Keita	Steven Williams	Testing the Ability of SecretomeP Prediction Software to Predict <i>Brugia malayi</i> Secreted/Non-Secreted Proteins	29
Caroline D. Keroack and Joy M. Lapsertis	Virginia Hayssen	Species-specific Morphology May Reveal Function of Earless Seal Vibrissae	30
Lydia-Rose Kesich	Michael Barresi	Analyzing the Teratogenic Effects of Macondo Crude Oil on Zebrafish Embryogenesis	31
Nida Khan	Robert Merritt and Laura Katz	To Characterize Sulfate-Reducing Bacteria in Avery Pond	33
Cait Kirby	Robert Merritt	What's Your Orientation: Long PCR Analysis of the Xq28 Region	34
Elissa Larabee	Virginia Hayssen	Influence of Body Size on Reproductive Trends in Canids (Canidae)	35
Da Yae Lee	Christine White-Ziegler	Temperature-Dependent Regulation of Fimbrial Phase Variation in <i>E. coli</i>	36
Claire Maesner	Stylios P Scordilis	HSP25 Immunoprecipitation from C2C12 Skeletal Muscle Cells	37
Paula Noonan	Virginia Hayssen	The Function of the Tail in Aquatic and Semiaquatic Mustelids	38



Biological Sciences *(continued)*

Name	Advisors	Project Title	
Deborah Ok	Michael Barresi	Radial Glia Vital for the Proliferation of Glia and Neural Populations in the Zebrafish Neural Tube	40
Jaclyn Perreault	Christine White-Ziegler	Thermoregulation of Various Genes in <i>Escherichia coli</i> K-12 at an Intermediate Temperature	41
Shannon Pettit	Christine White-Ziegler	Generating Images of Swarming Motility Across Strains of <i>Escherichia coli</i>	42
Siobhan Prout	Virginia Hayssen	Variation in Mustelid Hind Foot and Tail Length	43
Johanna Ravenhurst and Jenna Wurster	Steven A. Williams	Identification of <i>pdf-1</i> as a Functional Circadian Clock Gene in <i>Brugia malayi</i>	46
Jennifer Rioux	Michael Marcotrigiano	Tree Hazard Ratings at the Smith College Arboretum	47
Mikaela Sanders	Jesse Bellemare	Updating and Curating the Smith College Herbarium	48
Iju Shakya, Louise Hart Bodt and Krithika Venkataraman	Steven A. Williams	Decoding the Promoter Region of the Thioredoxin Peroxidase-2 Gene in <i>Brugia malayi</i>	49
Rachael Sirois	Steven Williams	Metagenomic Study of the Equine Gastrointestinal Tract before and after Treatment with the Anthelmintic Medication, Ivermectin	50
Francesca Tomaino	Steven Williams	A PCR-Free Assay for the Detection of <i>Brugia Malayi</i> in Mosquitoes	52
Kristine Trotta	Steven Williams	Methodology for the Isolation and Detection of Sesquiterpene Lactones in <i>Neurolaena Lobata</i>	53
Sarah Tucker	L. David Smith and Laura Katz	A Phylogeographic Comparison of the Invasive Green Crab <i>Carcinus maenas</i> in Relation to Claw Strength and Cuticle Thickness	55
Carla M. Vélez and Tatenda D. Mahlanza	Michael J. Barresi	Cellular and Molecular Characterization of Post-optic Commissure Formation in the Zebrafish Forebrain	57
Jessica Wignall	Steven Williams	Medicinal Plants: Hoax or Potential Breakthrough in Drug Development for Lymphatic Filariasis?	58
Cameah Wood	Laura Katz	Testate Amoebae and Discovering that Environment May Have Effect on the Population of a Species	61
Paula Zaman	Michael Barresi	Identification of Specific Zrf (2-4) Antibody Protein Targets in the Developing Zebrafish Brain	63

Chemistry

Name	Advisors	Project Title	
Metasebia Aberra	David Bickar	The Stabilizing Effect of Metalloporphyrins on Myoglobin	64
Yoon Bae	Elizabeth Jamieson	Impact of Spiroiminodihydantoin Lesion on the Stability of an A 15-MER DNA Duplex	65
April Birnie	Robert Linck	Factors that Affect the Inverted Umbrella Effect of $Mn(CO)_5X$	66
Sophia Carroll and Danielle Chichester	Elizabeth Jamieson and Cristina Suarez	2D NMR NOESY of 11-mer Control DNA Duplex	67
Tessa Clark and Gloria Ortiz	Kevin Shea	Cationic Diels-Alder Dienophiles Stabilized by Cobalt-Complexed Alkynes	69
Signe Dahlberg-Wright	Cristina Suarez	NMR Analysis of Ion Transport in Liposomes	70
Rosa Drummond	David Bickar	Dopamine Cytotoxicity and its Implications Pertaining to Parkinson's Disease	71
Elsa Hinds and Zulema Peralta	Kevin Shea	Development of a Tandem Diels-Alder/Pauson-Khand Reaction for the Synthesis of Tetracycles Mediated by a Cobalt-Complexed Alkyne	72
V. Garbo Garborcauskas	David Gorin	Selective Catalytic Chemistry Using DNA Aptamers	73
Esther Hong	Cristina Suarez	Ion Transport of Extruded Liposomes as Cell Membranes	75
Sarah Kay	Robert Linck	Energetic Comparison of S_N2 Self-Exchange Reactions on Pentacoordinate Carbon, Silicon, and Tin	76
Jiyeon Kim	David Gorin	DCats: Synthetic Tools for Selective Chemistry in Complex Settings	77
Colby R. Loew	Cristina Suarez	A ^{39}K -NMR Study of the Encapsulation of Potassium in Phosphatidylcholine Liposomes	79
Lauren Magliozzi and Jennifer Weng	Carrie G. Read	Cuprous Oxide Nucleation Density Investigation with Various Morphologies for Clean Energy Applications	80
Mojdeh Mostafavi and Julie Vallejo	Shizuka Hsieh	Effects of Hydrogen-Bonding on O-H Stretch Overtone Excitation for Fluorinated Hydroperoxides	82
Chioma Nwonu	Robert Linck	The Stability of Four Coordinate Sulfur Compounds and Five Coordinate Phosphorus Compounds	83
Hanyu Shi	Elizabeth Jamieson	Impact of the Oxidized Guanine Lesion Spiroiminodihydantoin on the Thermodynamic Stability of DNA	84

Chemistry *(continued)*

Name	Advisors	Project Title	
Kelly Smith	Kevin Shea	Purification and Synthesis of 2,6-dimethylcyclohexanol and Similar Cyclohexanol Analogues for Application as General Anesthetics	85
Yuan Ji and Jessica Sweeney	David Gorin	Methyl Transfer of Oxygen Nucleophiles in Organic Synthesis	86
Rumbidzai Vushe and Yamin Tun	Shizuka Hsieh	Hydroperoxide Photochemistry under Solar Wavelengths at Dawn and Dusk	88

Computer Science

Name	Advisors	Project Title	
Lucy Chikwetu	Judy Franklin	ChucK and the Keyboard Instruments Project	89
Julia Edwards	Judy Franklin	The Hallway Project: An Interactive Application Based in ChucK and Processing	90
Emily Flynn	Ileana Streinu	Developing a Method for DNA Sequence-based Rigidity Analysis	91
Janet Harris	Judy Franklin	Programming Sound with ChucK and TAPESTREA	92
Shannon MacKenzie	Eitan Mendelowitz	The Alignment of Two Partially Overlapping Point Clouds	93
Freda Moore	Judy Franklin	Making the Keyboard Instrument	97
Cordelia Nowak	Nicolas Howe	Handwriting Recognition in Classical Syriac	98
Weini Yu	Eitan Mendelowitz	Locative Media Development on Android	99



Engineering

Name	Advisors	Project Title	
Defne Abur	Susan Voss	Analyzing Inter-subject and Intra-subject Variability in Energy Power Reflectance	100
Wiame El Bouhali	Glenn Ellis	Designing Learning Environments for K-12 Engineering Education	101
Elizabeth Esposito	Reid Bertone-Johnson, Marcia McNally, Paul Wetzel and Susan Froehlich	Summer with CEEDS	102
Jennifer Holliday	Judith Cardell	Rural Electrification in South Africa: A Preliminary Study	103
Adrienne Horne	Judith Cardell	Renewable Energy and its Impacts on the Environment and Economic Development in Central China	104
Huimin Ji	Susan E. Voss	The Influence of MP3 Headphone on Human's Ears	105
Jinjin Lu	Judith Cardell	The Framework of Wind Energy Paired with Demand Response	106
June Lukuyu	Judith Cardell	Wind-Diesel Microgrid System for Remote Villages in Kenya	107
Mary McGrath and Alina Pechacek	Susan Voss	Otoacoustic Measurements on Patients with Idiopathic Intracranial Hypertension before and after Lumbar Puncture	108
Kate Meyer and Julia Signell	Andrew Guswa	Developing and Evaluating a Monthly Curve Number Method for Predicting Stormflow	109
Erika Miguel	Susan Voss	Measuring Otoacoustic Emissions Using HearID and Acoustic Processing Hardware	111
Xinyi Liu	Denise McKahn	Modeling and Analysis of Thermal Dynamics in Miniature PEM Fuel Cells	112
Yanning Yu	Glenn Ellis	Designs of Learning Environments in Undergraduate Engineering Education	113
Zhouchangwan Yu, Rumbidzai Vushe and Yamin Tun	Judith Cardell	Electricity Consumption Monitoring System	114



Environmental Science and Policy

Name	Advisors	Project Title	
Janet Burke	Joanne Benkley and Rebecca Wynne, Center for Coastal Management & Assessment, National Centers for Coastal Ocean Science, National Oceanic & Atmospheric Association (NOAA)	Science Communications and Legislative Outreach in a Federal Agency	115
Victoria Dunch	Joanne Benkley and Patricia Fair, Center for Coastal Environmental Health & Biomolecular Research, National Oceanic & Atmospheric Administration (NOAA)	Marine Mammal Health and Toxicology	116
Karen Gilbert	Paulette Peckol, Sara Pruss and Don Field, Ph.D., National Oceanic & Atmospheric Administration, Applied Ecology & Restoration Research Branch, Beaufort Laboratory, NC (NOAA)	Possible Seagrass Bed Fragmentation over Two Decades in Carteret County, NC	117
Elizabeth Gillespie	Joanne Benkley and Kerstin Wasson, National Oceanic & Atmospheric Administration, Elkhorn Slough National Estuarine Research Reserve and University of California, Santa Cruz (NOAA)	Increasing Native Olympia Oyster (<i>Ostrea lurida</i>) Recruitment	118
Kayla Clark, Lauren Malecky, Kaylyn Oates, Angela Oliverio, Alyssa Stanek and Megan Svoboda	H. Allen Curran, L. David Smith, Denise Lello and Miguel Alamilla, Jr., Manager, Hol Chan Marine Reserve	Coral Reef Ed-Ventures 2012: An Environmental Education Program Conducted by Smith College Students for Youth in San Pedro, Belize	119
Emily Peake	Joanne Benkley and Jennifer Dijkstra, PhD, National Oceanic & Atmospheric Administration, National Estuarine Research Reserve, Wells, ME (NOAA)	Effect of Habitat Structure Formed by Macroalgal Foundation Species on Associated Fauna in Rocky Intertidal and Marsh-Cordgrass Ecosystems	124
Lisbet Portman	Reid Bertone Johnson	Center for Environment, Ecological Design and Sustainability (CEEDS) Intern	125
Jenna Zukswert	Amy Rhodes	Comparing Throughfall Chemistry in a Mature Hemlock Forest and Early Successional Deciduous Forest at the MacLeish Field Station in Whately, MA	126

Name	Advisors	Project Title	
Sarah Brisson	Bosiljka Glumac	Distribution and Origin of Caliche Crusts in Ancient Sand Dunes on San Salvador Island, Bahamas	130
Katherine Broadwater	Robert Newton	Geochemistry of Avery Brook, West Whately, MA	131
Paula Burgi and Alexandria Julius	Jack Loveless	Analyzing Systems of Earthquake-Related Landform Deformation along the Chilean Coastline	134
Camille H. Dwyer	Amy Rhodes	The Hemlock Woolly Adelgids' Impact on Throughfall of Northeastern Forests: Throughfall Black Birch Amounts Are Greater than Throughfall Eastern Hemlock Amounts	136
Alexandria Julius and Paula Burgi	Jack Loveless	Use of GPUs for Crustal Deformation Modeling	138
Bismita Sahu	Jack Loveless	Revisiting the Slip Distribution of the 1994 Northridge, California Earthquake	140
Maggie Sawdy	Sara Pruss	Constraining the Record of Neoproterozoic Life: New Insights from Neoproterozoic Strata of Northern Namibia	141
Theo Sweezy	Amy Rhodes	Comparison of Nutrient Cycling in Secondary and Mature Deciduous Forest	142
Sophie Westacott	Sara Pruss	Lab Analysis of Samples Collected from Early Triassic Moenkobi Formation Carbonates in Nevada	143
Kate Aloisio	Minh Ly, Cate Rowen and Nicholas Horton	Early Research in Science, Technology, Engineering and Mathematics at Smith College	144

Mathematics and Statistics

Name	Advisors	Project Title	
Ruobing Zhang	Nicholas Horton	The Statistical Sleuth in R	146
Salma Bargach	Adam Hall	The Effects of Flavonoids on GABA _A Receptor Modulation via Patch-Clamping Electrophysiology and Tadpole Assays	147



Name	Advisors	Project Title	
Luvana Chowdhury	Adam Hall	Patch-Clamp Investigation of the Modulation of GABA _A Receptor Currents with Isomers of the Potential Anesthetic 2, 6-dimethylcyclohexanol	148
Ellen Gunzel	Annaliese Beery	Effects of Anxiety on Non-sexual Affiliative Behavior in <i>M. pennsylvanicus</i>	149
Amanda MacAvoy	Adam Hall	The Effects of Isoflurane Pre-conditioning on MTF-1 Translocation to the Nucleus in Neurons and Microglia <i>in vitro</i>	150
Belinda Nhundu and Shimu Liu	Adam Hall	Isoflurane Impacts the Actin Cytoskeletal Signalling Pathway Ppby Depleting Cofilin Reserves in Neonatal Murine Cortical Tissue	151
Lorna Pyle	Mary Harrington	Circadian Synchronization in Per2:Luc Transgenic Mice Hepatocyte Cultures	152
Helen Queenan	Mary Harrington	Long-Term Fatigue Causes Morphological Changes in Microglia	153
Kara Reitz	Annaliese Beery	Neuroendocrinology of Sociality in Meadow Voles	154
Alexis Ziemba	Adam Hall	Investigation of a Molecular Mechanism for Anesthetic Preconditioning	155

Physics

Name	Advisors	Project Title	
Rohini Ray and Ansha Zaman	Nathanael Fortune	Solar Collector	157



Psychology

Name	Advisors	Project Title	
Aqdas Aftab	Philip Peake	Telling Our Legacies Digitally (TOLD)	159
Jacqueline Baron	Peter de Villiers	Pragmatics in Children with High Functioning Autism Spectrum Disorders	160
Shiqian Mao	Bill Peterson	A Longitudinal Study of Personality and Life Outcomes	161
Katherine Margulis	Jill deVilliers	The Use of Small Clauses in Young Children: An Eyetracker Study	162
Mia Copeland-Brock	Fletcher Blanchard	“White” or “European American”: Priming In-group Prototypic Features versus Mere Self-categorization and Intergroup Differentiation	163
Tarra Murphy	Jill de Villiers	Creating a Mandarin Language Test in Order to Diagnose Specific Language Impairment in China	164
Christina Song	Nnamdi Pole	Examining the Correlates of Posttraumatic Growth in Retired Police Officers	165
Joselina Tejada	Peter and Jill de Villiers	Pilot Testing of a Spanish Computerized Preschool Language Assessment	166
Jennifer Tran	Beth Powell and Jennifer Martin McDermott, (University of Massachusetts, <i>Amherst</i>)	Individual Feedback Sensitivity to Social Self-Conscious Emotions	167
Xiaoye Xu	Bill Peterson	A Longitudinal Study of Personality and Life Outcomes	169



Mass Accretion and Ejection from T Tauri Stars

Wanda Feng

When a star is about a million years old, it has a protoplanetary disk of gas and dust that rotates about it – this is the T Tauri phase. Material in the inner disk is attracted to and follows magnetic field lines to the central star at high velocities, resulting in accretion shocks. At the same time, there are bipolar jets of material leaving the star. As this occurs, emission lines are formed and studying them can provide clues for the mechanism and impacts of accretion and ejection. A simultaneous data set for 31 T Tauri stars was used in 1995 to establish that there is a correlation between mass accretion and mass ejection rates. As part of my research, I used modern techniques and models to calibrate this correlation using the hydrogen-alpha line, supporting that mass ejection rates are approximately ten percent of accretion. Then, I looked at a data set of multiwavelength spectra for a subset of fifteen stars taken with the Keck telescopes at the Mauna Kea Observatory and the IRTF telescope. I was able to calculate line luminosities by measuring equivalent widths at specific wavelengths for select lines – hydrogen-alpha, Paschen-beta, Brackett-gamma, helium I, and calcium II – collecting photometry and extinction values at the correlated bands, and finding the fluxes for zero-magnitude stars. Accretion luminosities were then calculated using line accretion relationships for specific emission lines - these were subsequently used to determine mass accretion rates. By comparing the mass accretion rates per star as organized by veiling, the ratio between the excess and photospheric flux, we learned that there is generally a trend such that the lower the veiling, the lower the accretion rate - this will ultimately be used to analyze the emission lines in the future. I presented my research for the Five College Astronomy Department amongst my peers and professors in early August. (Supported by the Schultz Foundation)

Advisor: Suzan Edwards

Confirming a High-Redshift Galaxy Cluster

Isabel Lipartito

.....

Is it possible that a galaxy cluster could have formed in the early universe? My project for this summer involved reducing images and light spectra from a candidate galaxy cluster at redshift 2.3, or 10.8 billion years back to the Big Bang. This potential cluster, named the Coup-Fourré Galaxy Cluster, consists of twenty objects all believed to be at the same redshift, or distance from Earth. Current theory maintains that such a cluster could not have formed at this point in cosmic history. Images of this cluster had been made earlier using the Gemini North Telescope along with spectra for thirteen of its twenty objects.¹

Using the gemini reduction package from the IRAF (Image Reduction and Analysis Facility) software, I reduced the 55 images of the candidate cluster taken by the Gemini telescope and managed to flatten them with only one percent of the original sky level remaining. The best quality images (about one-third of the total) were combined into a final image and the individual galaxies were identified in that image.

The spectra were the key to confirming and analyzing this cluster. Star-forming galaxies, as these are believed to be, emit strongly in Lyman-alpha UV light. This light is red-shifted to the optical by the time it reaches us due to the expansion of the universe. The spectra were taken in the optical over a range of 400 to 650 nanometers. Still using IRAF, I then reduced the set of spectra the Gemini telescope had taken. There were twelve frames with the same thirteen spectra in each frame. Each frame was flattened and cleaned for cosmic rays. The sky level for each spectra was subtracted and the spectra were extracted into one-dimensional graphs of wavelength vs. intensity. If these galaxies are indeed at the same wavelength, we should detect strong Lyman-alpha peaks at 400 nanometers for each of the thirteen galaxies studied.

At this stage in the project, we have only detected Lyman-alpha peaks at 400 nanometers in three galaxies, indicating that these three are all at redshift 2.3. I intend to continue this project next year, as further work can be done with regards to extracting these spectra and reducing these images. It is possible that we will be able to confirm the redshift of a majority of our galaxies in the future, as well as doing photometry and other sorts of analysis on them. At the present, we have a high-quality image of our potential cluster and are on our way to derive information on its very nature. The significance of this whole project is that it aims to uncover information about the large-scale structure of the universe in its earlier years and document an important group of high-redshift galaxies. I have already presented my current work to other students and professors working through the Five College Astronomy Department. (Supported by the Schultz Foundation)

Advisor: James Lowenthal

The final image: each circle contains a galaxy

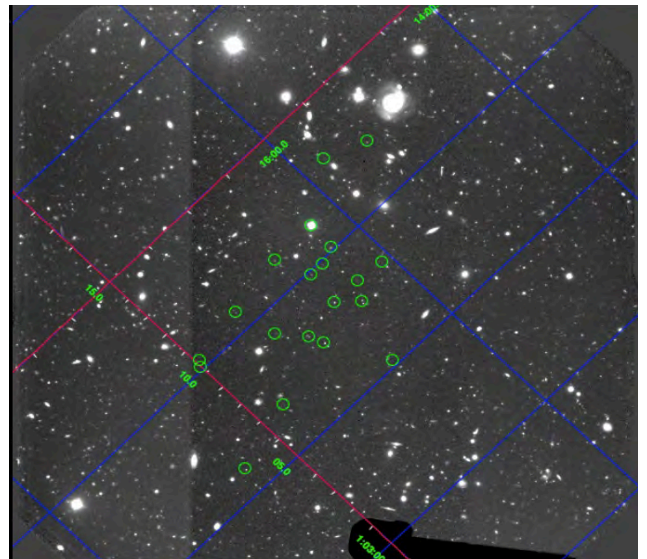

References:

¹Lowenthal et al. Deep Imaging and Spectroscopy of a Galaxy Proto-Cluster. NOAO Observing Proposal 2010.

Discovering Accretion Properties in Young Stars

Jenny Podel

.....

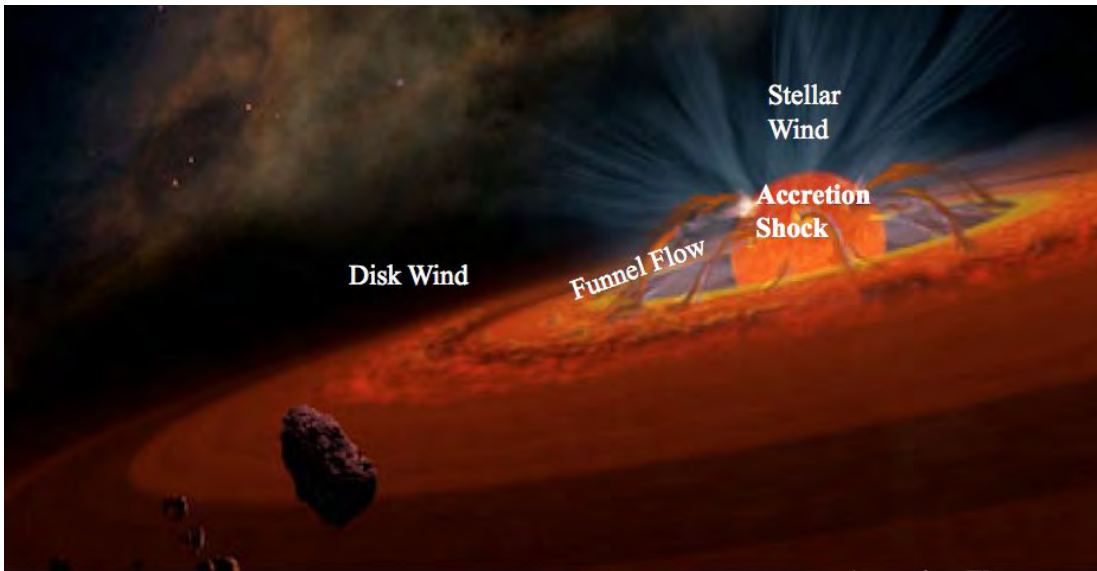

T Tauri stars are only one million years old and are still surrounded by accretion disks that are in the early stage of planet formation. Although we know that the power of the wind is proportional to the rate at which mass flows through the accretion disk, we do not know where in the system the winds originate- from the star, from the disk, or the region at the interface between the star and the disk.

I used a collection of high-resolution spectra of young stars taken with the Keck Telescopes using the optical HIRES and the infrared NIRSPEC spectrographs. I analyzed this data with a fitting program DAVE¹ that ran through the IDL programming environment. This allowed me to measure and study emission lines from hydrogen, helium, sodium, calcium, and iron, of which my main focus was on the Helium I and calcium II transitions.

I created residual spectral emission line profiles, this means I removed the contributions from the stellar photosphere from the emission lines by using a star of a similar spectral type as a template. Then I made multi-component Gaussian fits to the residual profiles. It turned out something new arose in the HIRES data. Previously, it was published² that two Gaussian functions could accurately represent the line profile, but with 1.5 X better resolution I discovered a third component was needed.

This will then be compared to different theories and models on star formation to find the density and temperature in the line formation region. This will give me some clues for the to where these strong winds originate. The third component that I discovered needs to be further investigated and added into theories to adjust their parameters to properly match the stellar data. (Supported by the Schultz Foundation)

Advisor: Suzan Edwards

References:

¹ DAVE Interface, Azuah, 2009, <http://www.ncnr.nist.gov/dave/documentation.html>.

² Helium Emission from Classical T Tauri Stars: Dual Origin in Magnetospheric Infall and Hot Wind Georgina Beristain, Suzan Edwards, and John Kwan, Five College Astronomy Department, Clark Science Center, Smith College, Northampton, MA 01063; sedwards@smith.edu, kwan@umass.edu Received 2000 September 10; accepted 2000 December 8.

Effects of Surface Chemistry on Biofilm Colonization

Minhee Kim, Jinglin Huang and Jing Zhang

The effect of surface chemistry on biofilm colonization has become a popular research subject in medical and environmental fields, with a growing public concern on biofilm coating on medical devices and water pipelines.^{1,2} Our summer research continued our previous study on the responses of *Pseudomonas aeruginosa*, a model organism in biofilm studies, to nanoscale surfaces with different physical characters.

Two types of nanoscale surface topography, flat hydrophobic and flat hydrophilic, were constructed and coated by *P. aeruginosa*, followed by a visual observation of biofilm growth under fluorescence microscope. The qualitative analysis on the arabinose-induced fluorescence, emitted by the attached bacteria, suggested that layers of bacteria start to accumulate and are discernible for measurement after six hours of incubation. Three ways to quantify the biofilm growth were performed to distinguish bacteria's response to two studied surface types. The first one is through TECAN Infinite M1000, a microplate reader capable of detecting and quantifying the fluorescence intensity emitted from areas of interest. TECAN data collected from three sets of experiments demonstrated a distinguishable difference between biofilm growth on flat hydrophobic and hydrophilic surfaces after six hours of incubation. The three-dimensional modeling of the spatial distribution of bacteria on the surface was enabled by Magellan, a software developed by TECAN Group. To prove the validity of results obtained through TECAN, the second quantification means was proposed, through which microscopic images were sampled from areas of interest and analyzed by an image-processing program named Image J.⁴ Sonication was carried out as a third way to assess the growing performance of *P. aeruginosa*. An ultrasound water bath⁵ was applied to remove attached bacterial cells from the surfaces and after centrifugation, cells were reintroduced in aliquots to growth media. Cell colonies were counted and the difference in colony-forming units appeared indicated that more cells were detached from flat hydrophobic samples compared to flat hydrophilic ones after six hours of incubation.

In continuation of our studies, the protocols developed from our summer research should be repeated for multiple times until substantial amount of data are gathered to draw the conclusion. To investigate the effects of surface roughness, protocols should be tested on rough hydrophobic and hydrophilic surfaces, in comparison to flat topography. (Supported by the Howard Hughes Medical Institute)

Advisors: Kate Queeney and Rob Dorit

References:

¹Mack D, Rohde H, Harris LG, Davies AP, Horstkotte MA, Knobloch JK. (2006). Biofilm formation in medical device-related infection. *International Journal of Artificial Organs*. 29 (4): 343-59.

²Pavanello G, Faimali M, Pittore M, Mollica A, Mollica A, Mollica A. (2011). Exploiting a new electrochemical sensor for biofilm monitoring and water treatment optimization. *Water Research*. 45 (4): 1651-1658.³The information of TECAN Group Ltd is available at www.tecan.com.

⁴The information of Image J is available at <http://rsbweb.nih.gov/ij/>.

⁵The information of Branson model 2510 sonicating water bath is available at <http://www.emersonindustrial.com/en-US/branson/Products/precision-cleaning/bench-top-cleaners/bransonics/Pages/default.aspx>.

Proteome Profiling of Development in C2C12 Cells

Katharine von Herrmann

The C2C12 murine cell line can be used to emulate human myogenesis providing a model system where one can begin to ask and answer questions about early development of our skeletal muscle system. This summer, the proteome maps of C2C12 cells at three time-points during cell differentiation were created using the technique of 2D-gel electrophoresis. Cells were harvested as myoblasts (mononucleated replicating muscle precursor cells), as early myotubes (multinucleated short muscle fibers), and as late myotubes (multinucleated muscle fibers that spontaneously contract in culture). The cell extracts harvested from each time-point were separated in one direction by isoelectric focusing based on their isoelectric points along a pH 5-8 gradient within a gel. The proteins were then separated in a second dimension based on their apparent molecular weights by SDS polyacrylamide gel electrophoresis. Protein spots stained with Coomassie Brilliant Blue R-250 were matched and compared among gels using PDQuest analysis software. Significant spots, $p < 0.05$, whose pixel intensities increased or decreased twofold between time points were marked for excision along with spots that appeared or disappeared between time-points (Figure 1). The protein spots will be digested into fragments, sequenced by HPLC/MS/MS and then identified using murine database bioinformatics.

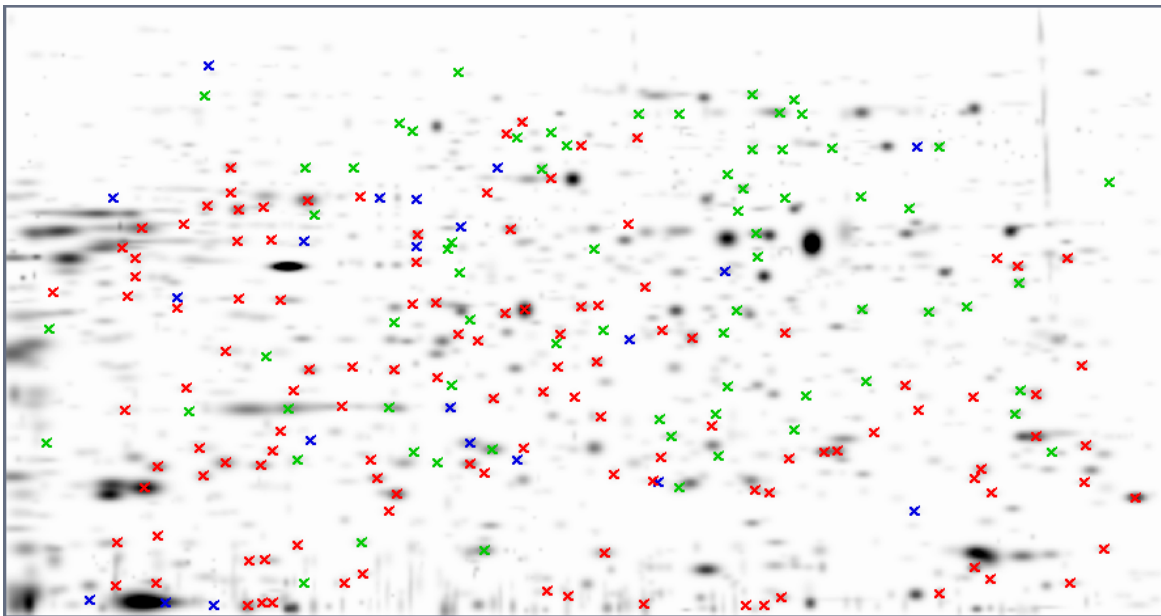

Figure 1: Master gel created by PDQuest that includes proteins present in at least three of five gels from each time point. Proteins that were excised are marked with an “x”. Excisions from the myoblast gels are marked in green, early myotubes excisions are marked in blue, and late myotubes marked in red.

Heat shock protein 25 (Hsp25) under normal conditions acts as a “molecular chaperone” assisting in processes such as protein folding, protein refolding, translocation, and prevention of protein aggregation to help maintain cellular homeostasis (Morton et al. 2009). Under conditions of stress, Hsp25 can be phosphorylated at Ser-15 and/or Ser-86 shifting the function of the protein (Stokoe et al. 1992). Hsp25 is involved in a variety of processes that support cell survival including protein refolding, modulation of actin while concurrently preventing apoptosome formation and caspase activation (Fulda et al. 2009). Myogenesis, the fusion of myoblasts into multinucleated, contractile filaments is a stressful process. The work this summer and continuing into the year will elucidate if Hsp25 plays a protective role in differentiating C2C12 cells by helping to maintain cellular homeostasis.

Hsp25 expression was quantified by immunoblotting a 1D-gel with a polyclonal anti-Hsp25 antibody. Expression increased from myoblasts to early myotubes, the point of initial fusion, and then decreased once the more stable late myotubes developed (Figure 2). These data indicate that the cells may be recruiting Hsp25 during the stress of fusion, however more studies are needed to confirm this correlation. The future trajectory is to establish the influence of Hsp25 on the entire proteome using an RNA silencing technique to knock-down Hsp25 prior to fusion. (Supported by the Wilens Fund in the Biological Sciences)

Advisor: Stylianos Scordilis

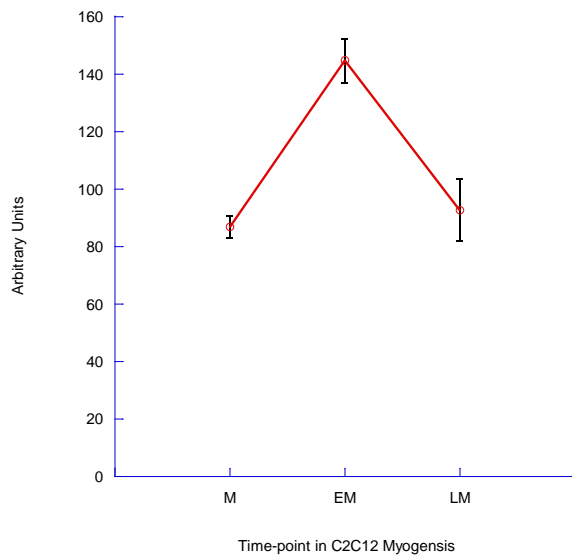

Figure 2: Hsp25 expression during C2C12 differentiation.

References:

- Fulda, S., Gorman, A., Hori, O., and A. Samali, 2010, Cellular Stress Responses: Cell Survival and Cell Death. *Intl J Cell Biol.* Article ID 214074: 23 pages.
- Morton, J., Kayani, A., McArdle, A., and B. Drust, 2009, The exercise-induced stress response of skeletal muscle, with specific emphasis on humans. *Sports Med.* **39**(8):643-662.
- Stokoe, D., Engel, K., Campbell, D., Cohen, P., and M. Gaestel, 1992, Identification of MAPKAP kinase 2 as a major enzyme responsible for the phosphorylation of the small mammalian heat shock proteins. *Fed Eur Biochem Soc.* **313**(3):307-313.

Two-dimensional Analysis of C2C12 Muscle Cell Line Development

Chelby Wakefield

.....

C2C12 cells are a line of mouse thigh muscle stem cells used to study the development of skeletal muscle *in vitro*. These cells start out as myoblasts that are committed to forming skeletal muscle. In low serum containing growth medium these cells exit the cell cycle and fuse together to form multinucleated early myotubes and eventually late myotubes which are the precursors to mature muscle fibers. This project focused on the differential proteome profiling of these cells as they progress from myoblasts to early and late myotubes.

The cells were grown and harvested at the appropriate stages (days 0, 4, and 10). Cellular extracts were then separated in two dimensions (2D); isoelectric focusing (IEF) and molecular weight. Isoelectric focusing separates proteins according to their isoelectric point, pI; the pH at which a protein carries no net charge. The second dimension separated proteins according to their molecular weight by SDS gel electrophoresis. Each spot on the gel represents one or more different proteins (Figure 1). The 2D gel results yielded changes in protein abundance between the three developmental stages; they were visualized by digital scanning and analyzed by PDQuest. Spots differing both by two-fold increase or decrease, as well as being statistically significantly different ($p < 0.05$) were identified. These spots will be cut out using a robotic spot-cutter, digested, and the protein identified using HPLC-coupled mass spectrometry during the upcoming year as a Special Studies project. (Supported by the Howard Hughes Medical Institute)

Advisor: Stylianos Scordilis

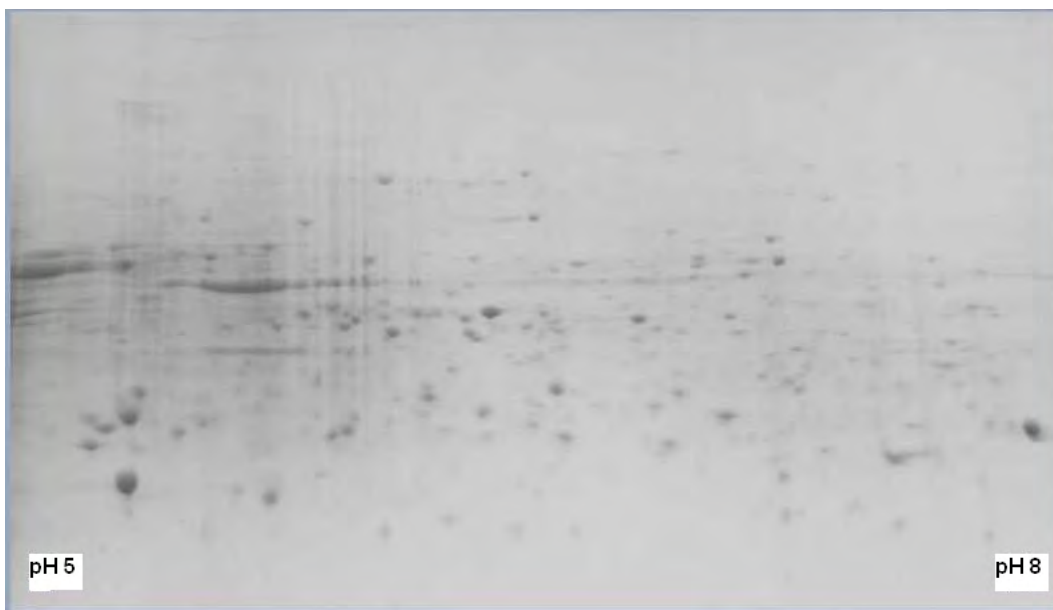

Figure 1. One of my 2D gels from a late myotube sample. Note that each spot represents a different protein with a different molecular weight or pI (large spots might be a few proteins overlapping). The proteins are separated on the horizontal axis according to their pI and on the vertical axis according to their molecular weight, with the heavier proteins towards the top of the gel and the lighter proteins making their way through the gel towards the bottom.

Analyses of the Relationship between Location and Microbial Community Diversity

Jessica Andrade

We inhabit a microbial planet, yet very little is known about the microorganisms around us. Though given little recognition, microorganisms form the basis for many ecosystems through their role in food webs, decomposition, and nutrient remineralization. Ciliates, especially the sister clades of Oligotrichia and Choreotrichia, make up an important component of the energy flow within of the marine ecosystem. A deeper understanding of the diversity of these organisms will provide richer insight into the structure of the oceanic food web.

Views on microbial diversity fall into two primary schools of thought. The first suggests that the distribution of all microorganisms is cosmopolitan and thus microbes are globally dispersed with no barriers to gene flow. The same microbes found in your local pond can be found halfway across the world. The second school of thought provides a contrasting theory arguing that most microbes are endemic: unique to one particular region. This theory maintains the idea that the microbe found in your local pond is exclusive to that location. However, analyses of microbial diversity have yielded an answer between these two beliefs. Microbial communities appear to be composed of a few dominant species and a large number of rare species whose geographic distribution is unclear. Due to this, specific locations can be intensely studied and still only provide information about a fraction of the world's microbial diversity. Comprehension of what factors influence certain species to be dominant and others to be rare species is a first step in grasping the elementary components of biodiversity.

Working collaboratively with others in lab, I addressed these issues using molecular tools to characterize the diversity of ONC from near shore environments. We used size fractionation filtering and denaturing gradient gel electrophoresis (DGGE) to analyze ciliate diversity both at different depths and different locations from the coast to open sea. Size fractionation filtering served to isolate the target organisms from a microbial sample for further study. Next we used DGGE as a means for collecting a community "fingerprint" through the identification of abundant species found within the sample. Based upon the nucleotide signature, each species' ribosomal gene denatures at a specific rate within the DGGE gel. Analysis of the resulting DDGE gels provides a picture of the community's overall diversity and suggests sampling sites that should be studied in more detail. (Supported by the National Science Foundation)

Advisor: Laura Katz

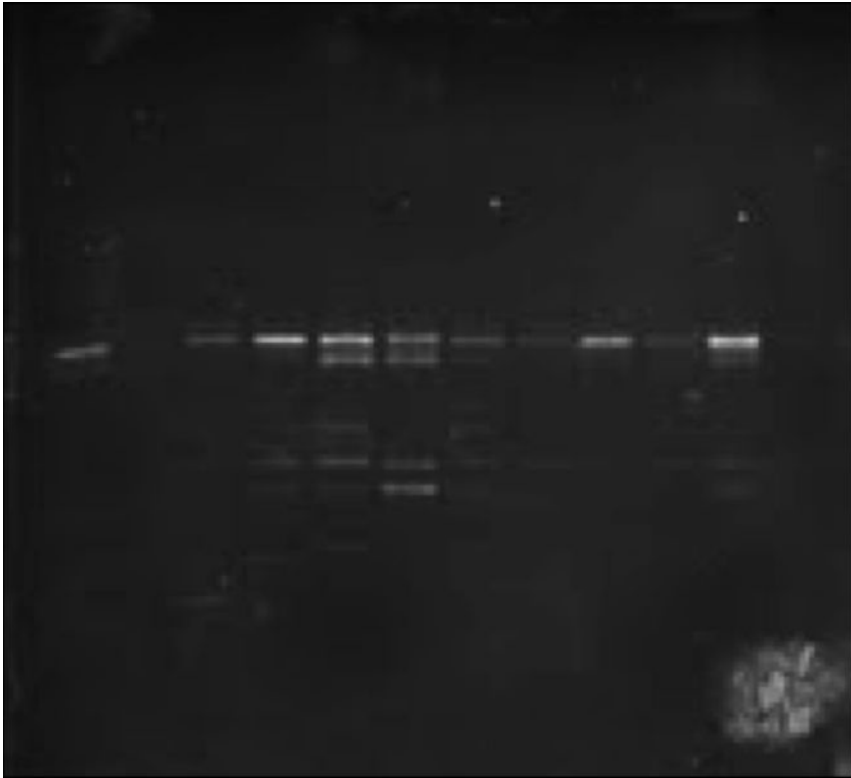

Function of Slit and Robo in Axon Guidance

Abigail Antoine and Jin Sook Park

Axon-glia interactions in the developing brain are caused by Roundabout receptors detecting the presence of Slit proteins. This signal-receptor pathway guides them to form proper connections within the central nervous system. What happens when one or more of these signals are missing? Using zebrafish as our model system, we were able to study embryonic forebrains to determine if specific mutations resulted in particular phenotypes, specifically in the formation of the post-optic commissure. Out of the many different mutant fish lines we had available to us, we focused on the Slit 2 and Slit 3 mutants, as well as Astray/Twitch-twice double mutants.

As the embryo brain develops, glia act as a substrate on which axons projecting from the retina move across in order to form the post-optic and anterior commissures. The Slit 1a protein acts as a chemoattractant, positively guiding the axons along the right path, while Slit 2 and Slit 3 act in the opposite manner, as a chemorepellant, preventing axons from straying too far from where they are supposed to be.¹ In a mutant fish, one or more of these proteins or receptors are missing or nonfunctional, and this would affect formation of the commissures.

To pinpoint a specific phenotype within each mutant group, we examined developing embryos and tried to observe if there were any abnormal behaviors or physical characteristics. At about 32 hours post fertilization, specific proteins were labelled within the embryo using immunohistochemistry, which would fluorescently label for axons and glia. This labeling allows us to examine the commissure formations and compare the forebrain images to a control group in order to determine the existence of mutant phenotype.

Since Slit 2 and Slit 3 were believed to have similar roles in axon guidance, it was unclear whether or not a loss of function in only the Slit 3 protein would show any distinct abnormalities or whether Slit 2 proteins would be able to compensate for the loss of the other chemorepellant. This examination process was made more difficult by the fact that the genotyping protocols for the Slit 2 and Slit 3 mutants were not working properly at this time, which inhibited us from processing a group of confirmed mutants for either fish line. In groups of potential Slit 3 mutants, there were instances of defasciculation of the commissure. Potential Slit 2 mutant embryos were separated by observed behaviors, such as a circular swimming pattern or deafness, and analysis of the commissures will be continued during the semester. Genotyping would be the next step in order to identify confirmed mutants. However, further examination of both mutant lines must be completed in the year to follow in order to confirm phenotypes. (Supported by the Blakeslee Fund in the Biological Sciences)

Advisor: Michael Barresi

References:

¹Barresi, M.J. 2005. Hedgehog regulated Slit expression determines commissure and glial cell position in the zebrafish forebrain. *Development* 132, 3643-3656.

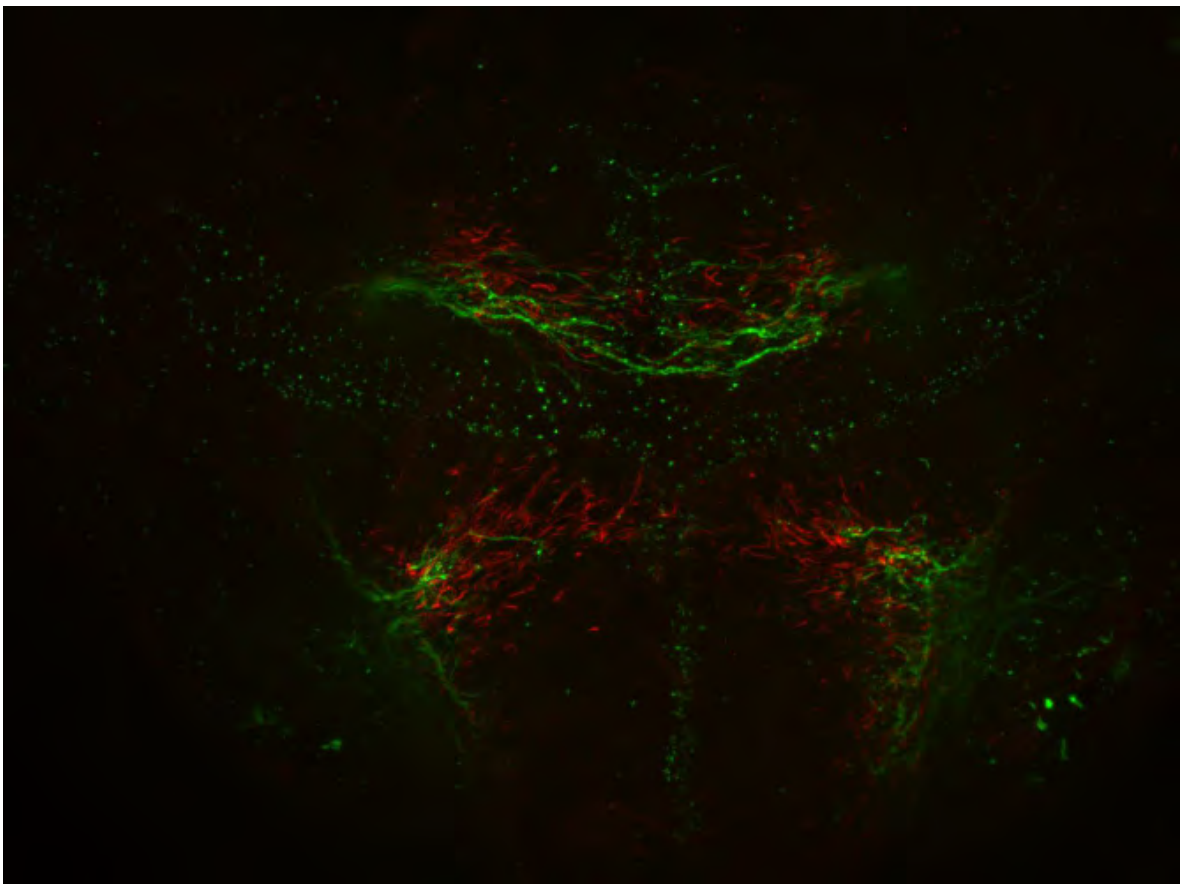
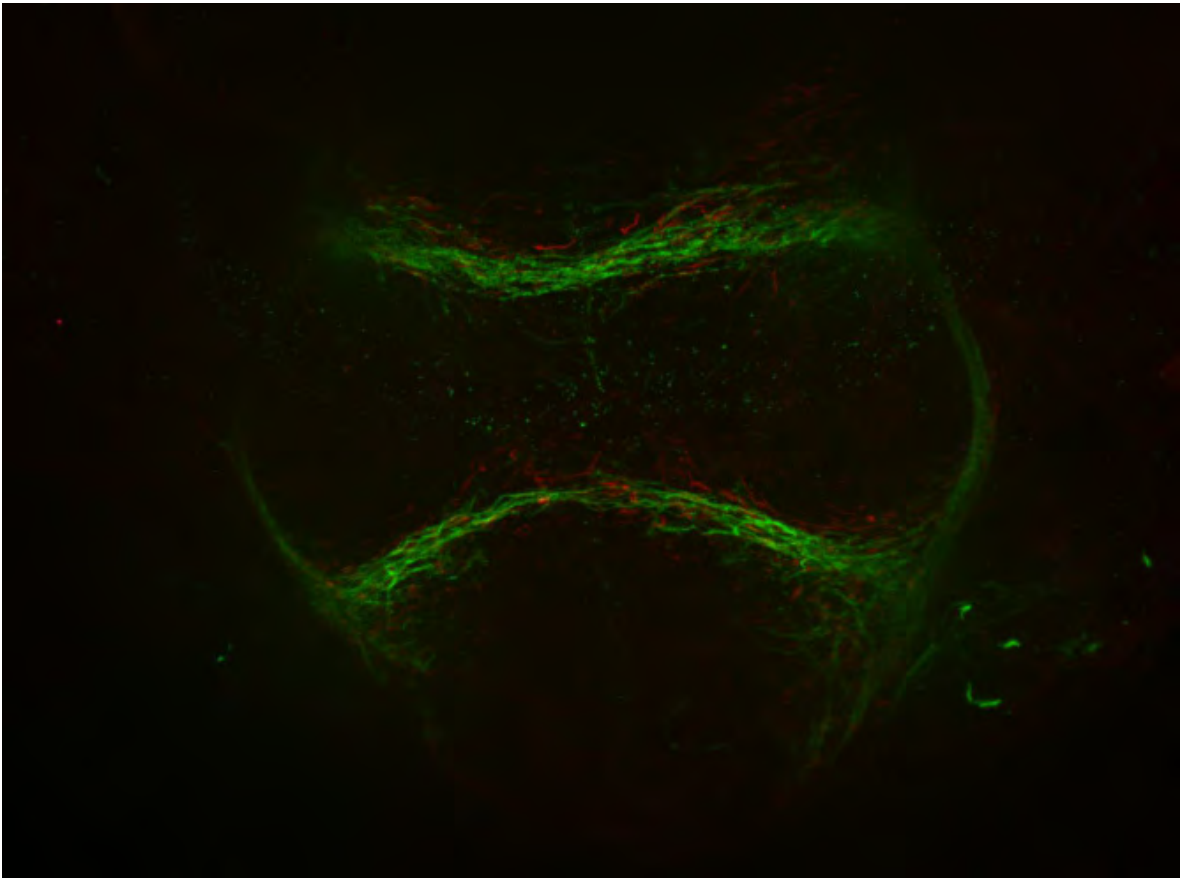

Developing Forms and Maps for Data Collection for the Botanic Garden

Emily Barbour



The Botanic Garden of Smith College currently uses a closed source database called BGBase. Though this database fits the needs of the botanic garden well because it was designed specifically for botanic gardens, it also has certain drawbacks. Understanding BGBase requires detailed training and data entry is very time consuming because data from other programs cannot be imported into BGBase. However, two groups are currently working on developing software that would link BGBase first to Sequel Server, then, through this, to ARCGIS. In anticipation of this, an effort at Smith College has been made to prepare for the potential advantages of the new interaction between the databases. My specific focus in helping in this effort was to create forms that would allow Botanic Garden staff and interns to collect data in the field and then import the information directly into BGBase.

This summer I created four forms: a horticulture task form, plant move form, dead plant form and an inventory form. I tested both FileMaker and Formstack as the programs to build the form, but FileMaker was ultimately chosen for our purposes because it functions as a database and because it is supported by Smith College. To design the forms I first had to go onto BGBase and familiarize myself with the structure of the tables within the database and the fields in BGBase that correlated with the fields on the paper forms that are currently being used and served as a model. When I isolated the fields I exported the data from BGBase to populate the forms. Once the data were imported into the tables I created in FileMaker, I built relationships between relevant tables to auto populate certain fields so the forms would be easier to fill out. Using the data from BGBase, for example, if you enter the name of a plant from the collection, the accession number will automatically be filled in. This would be especially useful for populating codes necessary for BGBase that most people don't know. My hope is that these forms can be put to use to make data collection in the field simpler and data entry into BGBase more streamlined.

I also worked on digitizing a map of all of the water spigots on campus, as there is no known record of them and it can be time consuming to locate them if you don't know where they are. Because there is no list of the locations of the spigots, I systematically walked the perimeter of each building on campus. When I found a spigot I would mark its location on a map that I printed of the building's shadows. We determined the GPS mapping units should not be used because their accuracy lessens the closer you stand to a building while mapping a point, and the spigots are all located on the sides of the buildings. I also collected relevant data about the spigots as I mapped them: whether they are keyed or not, whether they are functioning or not and any abnormalities with the spigots. I included this information with the location of each spigot in ARCMAP, so each spigot can be classified and sorted within the program. Using this information I created a report of which spigots weren't functioning as well as visualizing what areas on campus are outside a two hose radius from a water spigot. It is my hope that this map can be used not only to help workers find the spigots when they need to use them, but to monitor problem areas that are particularly far from any spigots and maintain spigot functionality. (Supported by the Schultz Foundation)

Advisor: Michael Marcotrigiano

The Spatial Distribution of Planktonic Ciliates off the Coast of Rhode Island

Kate Brien

.....

Planktonic ciliates are important members of the oceanic food web, forming the basis upon which many larger organisms rely. They can also be bio-indicators of microenvironments in the ocean. Understanding the distribution and diversity of various species of ciliates may lead to a better understanding of the ocean and even the effects of global warming.

We examined the molecular diversity of ciliate samples collected from a range of depths and distances off the shore of Road Island. Our filtering methods allowed us to look at the DNA of all things between 80um and 2um. This size frame blocked almost all larger organisms such as copepods and allowed bacteria to pass through uncollected. The filters were stored in DNA prep buffer until the DNA could be extracted using Phenol and Chloroform, adding RNase to ensure that only DNA was saved. The DNA was PCR'd using GC primers and then run through Denaturing Gradient Gel Electrophoresis (DGGE), which displayed bands of DNA supposedly representing different haplotypes of ciliates. Lastly, we sequenced the brightest of these bands and used BLAST to determine the identity of the ciliates in the sample. Many of the samples had yet to be sampled by the end of the ten weeks, and so results have not been determined yet.

We also worked on improving steps in the protocol for analyzing samples. Because we had been receiving mixed results from sequencing, we tried several different methods to find the most effective sequencing protocol. We found that pre-cleaning DNA using exosap or MicroClean was not needed and that sometimes uncleaned DNA showed up stronger on an agarose gel. We also found that PCRing DNA before sequencing was necessary for the sequences to work.

Research into the diversity and ecology of marine ciliates has led to many improvements and adjustment in the way we sample. No broad conclusions can be made, but small discoveries such as the presence of ciliate diversity 850 meters underwater encourages one to continue searching. I am looking forward to continuing research regarding the molecular analysis of ciliates over the school year. (Supported by the National Science Foundation)

Advisor: Laura Katz

Map of sampling sites, courtesy of Dr. Jean-David Grattenpanche



Smith College's Bird Collection: Accession & History

Diane Chen

Smith College's bird collection located in room 205 of the biology department is a treasure trove assemblage of useful teaching materials and wondrous scientific fascination. The room is filled with 116 mounted and stuffed birds, standing tall above the students in the vertebrate biology lab, and others curious enough to enter. They pose silently but regally, almost ready to jump back into life and fly from their taped glass enclosures. Behind their pearly black eyes and pointed beaks are a mystery shrouding their arrival to Smith College. With no tags or plaques to identify their origin, these birds remain as an untapped wealth of knowledge in historical significance and scientific research. Multiple stories can explain the accession of these birds to Smith College. All of the birds mounts however date back to the early 1900s or earlier, when Smith College was becoming established.

The accession of the bird collection could have started in 1885 with Florence Augusta Merriam Bailey's founding of the first charter Audubon Society at Smith College.¹ This historical event not only showed women successfully in the forefront of leadership, but would later trigger many more Audubon charter societies at other schools. The organization of the Smith College Audubon Society was a response toward the unrighteous slaughtering of whole birds to be adorned on women's hats as decoration.¹ Bailey gathered students to campaign to outlaw this crime by showing the public how unjust these killings were. Articles were written in protest to newspapers.

Bailey was a student at Smith College from 1882 and 1886.² She had a great fascination with birds and would later become a reputable ornithologist. She took a novel step in deviating from how most ornithologists studied birds². Instead of studying the bird's "skins" (as was popular at the time), Bailey would guide students on bird walks to observe living birds in their habitat. She later became an influential writer in the National Audubon Society's magazine. Bailey did not support the hunting or trapping of birds, however due to this period of large bird appeal, the bird collection could have been started.² Because some of the hats had whole birds attached, they were well-preserved specimens that could be easily removed and later mounted.

Another speculation on the origin of Smith College's bird collection was its participation in a larger collection known as the Wilder Collection.³ The Wilder Collection dates back from 1902 through 1920, with Professor Harris Hawthorne Wilder as the main collector. He was a well-known anthropologist who was also interested in salamanders. The most extensive part of his collection consisted of human skulls and artifacts. Most of the specimens were later given to the University of Massachusetts Amherst, to be added to their anthropology department. However, in the Smith archives, under the Wilder Collection archive box, there is a folder that reads "Wilder Collection—Bird Mounts and Human Skulls."³ In this folder are a few correspondences about the bird mounts; however, the majority of the archival material is about the human skull collection and its present whereabouts.

Elizabeth Horner, a Smith College biology professor from 1938 until 1986, had oversight of the Smith College bird collection as seen in her correspondence with Mary Leprade, a visiting professor by the name of "Elliot," and Arcadia Wildlife Sanctuary.⁴ On August 30, 1983 Professor Horner wrote to Mary Leprade saying she was "sorting and rearranging the birds" and also "directing 13 duplicates to an appreciative Arcadia. The correspondence between Leprade and Horner show that the bird collection definitely was already well established and needed an "update." In Betty's letter to the visiting professor "Elliot," Horner replies in her letter, "Please know that it will be my pleasure always to provide you with whatever specimens I can spare from my personal collection."⁵ The visiting professor borrowed a blue heron. Horner could have donated some of her own bird mounts to the collection, if she had any. Because she was a professor from the biology department, her personal collection could also be an informal description of the already existing Smith College bird collection.

The origin of the bird mounts could also be the Forbes Library. Within the Wilder Collection Bird Mount folder in the archives is a newspaper article from *Hampshire Life*, September 22, 1994, about the bird collection on the second floor of the Forbes Library⁶. Before the 1960s, the Forbes Library carried a vast collection of more than 300 species of birds. Sometime after the 1960s the birds were moved to the Audubon Society in Lincoln, Massachusetts. Perhaps Smith College had obtained some bird mounts from the Forbes Library before all of them were moved to Lincoln.

The Smith College bird collection could have been from Florence Merriam's Audubon Society at Smith College, the Wilder Collection, Horner's own personal collection, or from the Forbes Library. The speculation of placing the bird collection within the Wilder Collection seems to be the most probable origin. However, one can also make strong arguments to its accession during the establishment and protests made by the Smith College Audubon Society in 1885. However, it is very important to note that the Smith College bird collection is part of the Smith College history. The knowledge it will provide to the present and future students of Smith College is invaluable. The historical significance, whichever story it holds true, is priceless. (Supported by B. Elizabeth Horner Fund in the Biological Sciences)

Advisor: Virginia Hayssen

References:

¹Horner, Elizabeth, and Keir B. Sterling. "Feathers and Feminism in the 'Eighties.'" *Smith College Alumni Quarterly* (April 1975).

²Bailey, Florence Merriam. Papers. Sophia Smith Collection, Smith College, Northampton, Mass.

³Wilder Collection. Papers. Sophia Smith Collection, Smith College, Northampton, Mass.

⁴Elizabeth Horner to Mary Leprade, 30 August 1983, B. Elizabeth Horner Papers, Sophia Smith Collection, Smith College, Northampton, Mass.

⁵Elizabeth Horner to Elliot, 24 July 1985, B. Elizabeth Horner Papers, Sophia Smith Collection, Smith College, Northampton, Mass.

⁶Parsons, Jim. "Ton the Trail of a Flock that Flew the Coop." *Hampshire Life* [Northampton] 22 May 1994, 2nd edition: 2-3.

Soil Seed Bank Exploration: Comparing Secondary Hemlock, Old Growth Hemlock and Black Birch Forests

Meredith Gallogly and Stephanie Acevedo

A soil seed bank refers to the accumulation of dormant seeds in the soil of an ecosystem. Soil seed banks often play a critical role in ecosystem recovery following disturbance or destruction of above-ground vegetation. These seed bank-based recovery processes may be especially relevant to forests dominated by hemlock (*Tsuga canadensis*), where there tends to be little pre-existing understory vegetation due to low light and limited nutrient availability, due to hemlock's dense evergreen canopy and acidic leaf litter. The contents of a soil seed bank, particularly deeper soil layers, may also illuminate the longer-term vegetation history of a site, as it may include seeds of plant species that have lived at a location in the past but are no longer present above ground. In the present study we compared the content of the soil seed bank in three distinct forest types: 1) secondary hemlock-dominated forests growing on former agricultural land from the 1800s; 2) logging-generated gaps of about a 25 year old forest dominated by black birch (*Betula lenta*) saplings found within the secondary hemlock forest matrix; and 3) old growth hemlock forest that has not experienced significant human disturbance in the past 200-300 years. Both the secondary hemlock forest and black birch gap forests were located at the Smith College MacLeish Field Station in Whately, MA. Most of this upland site was cleared for farming in the late 18th and 19th centuries, but late 19th century declines in agriculture led to widespread reforestation in the 20th century. The secondary forest that developed was then partially logged in the late 1980s, a human disturbance which resulted in small clear-cut gaps filled with young birch saplings surrounded by the more mature hemlock forest. The old growth hemlock forest sites were located at the Bryant Homestead Preserve in Cummington, MA and the Mt. Toby Demonstration Forest in Leverett, MA.

The three forest types represent an important system for investigating forest soil seed banks, as hemlock is currently threatened by the Hemlock Woolly Adelgid (HWA; *Adelges tsugae*), an invasive insect pest that is expected to largely eradicate hemlock in the coming decades. Current research suggests that *B. lenta* will replace declining hemlock forests, as it has in the logging gaps at the MacLeish Field Station; however, there is also potential for species from the soil seed bank to contribute to the new vegetation, depending on light and disturbance levels during hemlock decline. This drastic shift in the dominant tree type in these communities is expected to alter many ecosystem characteristics, including nutrient cycling processes and the contents of the soil seed bank. Additionally, because differing levels of disturbance during hemlock decline might trigger germination from different components of the soil seed bank (e.g., shallow vs. deep), we collected soil samples from both the surficial organic layer of the soil, which contains mostly seeds that have accumulated in recent years, and the deeper mineral layer, which contains older seeds that have likely been preserved in the soil for a longer period of time (e.g., decades). Here we sought to examine current soil seed banks in these three forest types to predict changes that may occur in the vegetation of these forests in coming decades, as well as to understand how site history might influence the species composition of the soil seed bank.

In June and July 2012, we collected soil samples at the MacLeish Field Station in four hemlock forest plots and three birch logging gap plots; we also collected soils from two plots in the examples old growth hemlock forest in Cummington and Leverett. Within each plot, we collected soil at ten sample points; with one liter of surface organic material and one liter of mineral soil (0-10cm depth) extracted at each point. Soil samples were homogenized in the lab, and the mineral soil samples were sieved to < 2 mm to remove rocks and roots. The samples were placed into 20 x 30cm seed flats, with organic vs. mineral material from each sample point occupying half of each flat. The samples were then placed in the student greenhouse section of the Lyman Plant House at Smith College and were surveyed on a weekly basis for seed germination and seedling identification.

We found that, on average, significantly more seedlings germinated in the secondary hemlock soil samples than did in the birch gap samples, and this pattern held for both the organic and mineral soil layers (Wilcoxon nonparametric test: $p < 0.001$; $p < 0.007$). There are several possible explanations for this disparity. First, a seed bank may take many decades to accumulate in the soil. When the birch gaps were heavily disturbed by logging in the 1980s, a majority of the contents of the seedbank in the newly uncovered soils may have germinated, depleting the seed bank in these areas from its earlier levels. The subsequent 25 years may not have been enough time to restore the seed bank to its pre-disturbance levels. Second, it is also conceivable that the lower, less dense canopy of the young birch forest is a less favorable habitat for roosting birds as opposed to the dense hemlock canopy.

As birds are the major dispersal agents of fleshy-fruited plant species, their roosting behavior could alter ‘seed rain’ in the birch gaps, leading to fewer seeds entering the soil seed bank during the past ~25 years. Finally, it is possible that the micro-environmental conditions of the soil under a birch-dominated canopy are different from those under a hemlock-dominated one (e.g., drier, warmer), and these conditions may not be as suitable for the long-term preservation of seeds in the seedbank. Further research will be necessary to distinguish among these and other possibilities.

We also found that the mean abundance of seedlings in the secondary hemlock forests was greater than that of the old growth hemlock forests (Wilcoxon $p < 0.001$). If we assume that both types of hemlock forest have comparable soil conditions and levels of bird activity, this disparity may be partially the result of forest location and composition. The difference in mean abundance can be somewhat attributed to the overwhelming numbers of birch seedlings that germinated from the organic soil samples taken from the secondary hemlock forests. It appears that *Betula lenta* had a bumper year at MacLeish, as birch seedlings were extremely abundant in the organic soil samples from the field station. Birch seeds are preserved in the seed bank for only one-two years, so the seedlings that sprouted are mostly from last year’s seeds. The birch trees in the old growth forests on Mt. Toby or the Bryant Homestead may not have been so successful, or there simply may not be as many adult birch trees in these old growth forests to contribute to the soil organic layer’s seed bank. However, the glut of birch trees does not entirely explain the disparity in seedling abundance between the secondary and old growth hemlock soils, as even when the birches are removed from seedling counts, the secondary hemlock soils still contain a significantly higher average number of seedlings ($p = 0.021$). Notably, we did observe early trends toward differences in the species composition of secondary vs. old growth hemlock forest soil seed banks, with more open habitat and disturbance-related species being present in the secondary forest samples, likely tracing to the presence of pasture and field vegetation on these sites in the late 1800s. This finding suggests that some “weed” seeds may persist in the soil seed bank for 100 years or more. These patterns will need to be confirmed as plant specimens mature and are definitively identified. (Supported by the B. Elizabeth Horner Fund in the Biological Sciences)

Advisors: Jesse Bellemare and L. David Smith

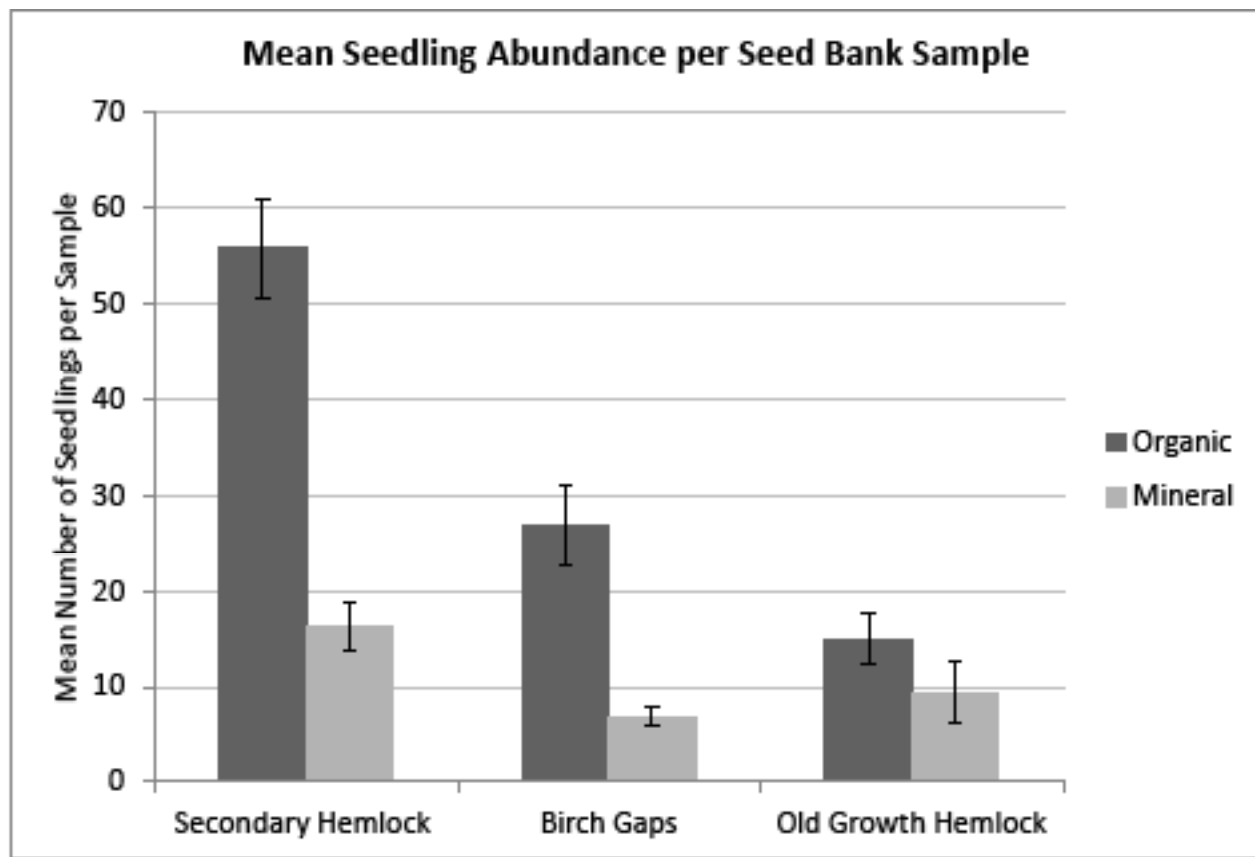

Fig. 1. The mean number of seedlings per sample in the organic and mineral soil of the three forest types.

The Diversity and Ecology of Testate Amoebae in Bogs and Fens

Adelaide Gordon

Testate (shelled) amoebae are a non-monophyletic group of Eukaryotic organisms that are highly sensitive to their environment. Understanding both the specifics of how these amoebae interact with abiotic features surroundings and how different morphospecies are related to one another will shed light on biodiversity and biogeography. Testate amoebae are grouped within Amoebozoa and Rhizaria and live on the *Sphagnum* moss in bogs and fens, which are wetlands with low pH and particular hydrology.¹ These organisms are ecologically important and are used in climate change studies as well as paleoenvironmental studies, although much remains to be learned about their biology. A crucial question that needs to be answered to fully understand the amoeba and their relationship to the environment is the question of their genetic diversity.² Historically testate diversity and evolutionary relatedness have been estimated by test (shell) morphology. However, this method could underestimate the amount of genetic diversity that exists in the group thus limiting our picture of biodiversity.² Additionally, by applying this information on biodiversity, we can begin to unravel questions about why some morphospecies are observed in a particular section of their environment and not in another.³ This information will help inform studies that use these organisms to obtain data on the effect of climate change in these ecosystems in addition to studies of biodiversity.

I worked to characterize the diversity of amoebae from various bogs and fens. Collaborating with others in the lab, we used molecular techniques that targeted the amoebae actin gene to assess the evolutionary relationships of organisms isolated from samples of *Sphagnum*. In addition, we collected data from the sites the where the moss was taken, in order to determine what abiotic factors affected the composition of amoeba communities. These data included pH, hydrologic setting or wetness of setting, depth to ground saturation point, and isotope ratios of the water.

Preliminary analyses indicate that amoebae communities vary within samples taken from the same bog or fen and seem to be affected by factors like wetness of the setting and pH. Despite difficulty getting reliable molecular data over the summer, previous work done on the project supports that relationships gauged using gene sequences are not similarly reflected by traditional morphological techniques.

The biodiversity within this group of organisms is underestimated by morphology and the ecological preferences of the organisms are critical to understanding their biogeographic distribution.^{2,3} By continuing to map evolutionary relationships with more amoeba samples and with other genes, like the small subunit ribosome gene, we can continue to develop our analysis. Similarly, by examining other factors that may be influencing the ecology of these amoeba, like dissolved carbon and oxygen, we might be able to form a more complete picture of how and why they prefer to live in one location and not another within the same bog.³ Overall, gaining a more complete understanding of these organisms will aid us in assessing our world at the microscale. (Supported by the Margaret Walsh Grantham Fund)

Advisor: Laura Katz

References:

- ¹Charman, D. J. (1997). Modelling hydrological relationships of testate amoebae (protozoa: Rhizopoda) on New Zealand peatlands. *Journal of the Royal Society of New Zealand*, 27(4), 465-483.
- ²Kosakyan, A., Heger, T. J., Leander, B. S., Todorov, M., Mitchell, E. A. D., & Lara, E. (2012). COI barcoding of nebelid testate amoebae (amoebzoa: Arcellinida): Extensive cryptic diversity and redefinition of the hyalospheniidae schultze. *Protist*, 163(3), 415-434.
- ³Mieczan, T. (2009). Ecology of testate amoebae (protists) in *sphagnum* peatlands of eastern poland: Vertical micro-distribution and species assemblages in relation to environmental parameters. *Annales De Limnologie - International Journal of Limnology*, 45(01), 41.

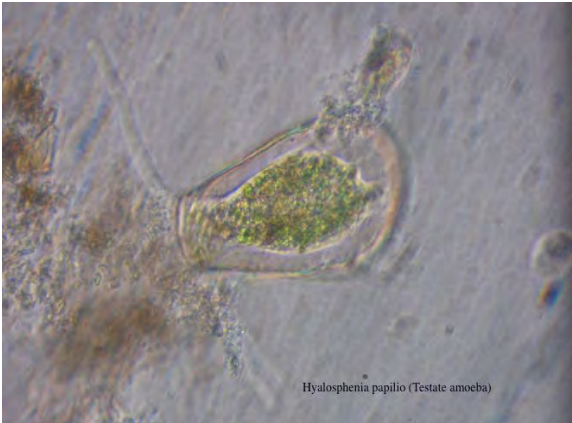

Hyalosphenia papilio (Testate amoeba)



Heath Bog, Acadia Maine

Landscape Field Studies

Seneca Gray



Landscape Studies students have been doing research in the Ward 3 district of Northampton for a few years now. The studies and projects reflected the interests and desires of the residences in the area. Clients would approach the department with a proposal in mind, or the students would engage the citizens in community forums to talk about the broad scale neighborhood landscape. Since the entire research program is generated and inspired by the Ward 3 public, it is natural to inform them of the projects Smith students have been producing. For this, we used the computer design software, InDesign, to format a booklet of the program, it's intent, it's progress, and all the projects already created that will be accessible to the public. Two reports, or "primers," were compiled: one featuring highlights of Smith's entire Ward 3 investigation, and one specifically focused on projects for the Cutchins School of Ward 3. Sifting through previous programming as well as doing our own data collecting was a significant part of the process. The final products took weeks to layout the master design template, and apply and edit the information.

The Landscape Studies department is also heavily involved with the creation of the Bechtel Classroom at the MacLeish Field Station. The BEC reflects Smith's commitment to sustainability and the liberal arts. I was asked to design a pavilion to accompany the BEC at the field station. The process started with personal site analysis and meetings with my professors, along with professional engineers and building contractors. Using AutoCAD, a drafting software, I composed floor plans, layouts, elevations and material diagrams that were authentic enough for professional use. However, most importantly, I devoted a majority of my time to understanding the aesthetic pleasure of the pavilion. The location of the building, the people using it, the purpose of its creation are all extremely important to understand. Through the site visits and meetings, I was able to design and adjust the pavilion so that my vision for its existence was met. (Supported by the Smith College Botanic Garden Landscape Studies Fund')

Advisor: Reid Bertone-Johnson

Creatine Kinase during Muscle Development

Hailun Li

Creatine kinase (CK) plays a major role in catalyzing the conversion of phosphocreatine and ADP into creatine and ATP, which provides nearly instantaneous ATP regeneration to many cell types with a high energy demand. Thus, it is not surprising that CK is found in mature muscle cells, but when does it appear in the development of muscle cells? This summer, I quantified CK in the three developmental stages of the C2C12 cell line, myoblast (M), early myotube (EM), and late myotube (LM).

Several techniques were used: cell culture; cell lysis; sample protein estimation (Lowry assay); protein separation through SDS-gel electrophoresis, along with a CK standard curve; immunoblotting to a PVDF membrane, which was probed using an anti-CK primary antibody at 4°C overnight; followed by quantitative gel densitometric scanning.

As I presented to my peers in the lab, CK exists at relatively low levels in all three stages (Figure 1). While a CK band is clearly observed on the lane with 0.2 µg of the adult skeletal muscle cell extract sample, it was not found in gel lanes with 20 µg of the myoblast, early myotube, or late myotube cell samples. Increasing the loadings to 50 µg of cell extracts, a band could be seen at relatively low intensity for each cell sample. Preliminary quantitation (Figure 2) demonstrates that CK exists at the highest level in early myotubes and the lowest level in myoblasts, although the differences between the stages are small in general.

Despite the high level of creatine kinase in mature muscle cells, its low level in the developmental stages indicates that its increase in amount may happen relatively late in cell maturation. However, this result and the differences between the stages in the quantification should not be considered significant until the experiment is repeated with further optimized conditions. Aside from this, I hope to identify the band on each lane of the cell samples, study more about creatine kinase with 2-D gel techniques, and continue this project into the coming academic year. (Supported by the Howard Hughes Medical Institute)

Advisor: Stylianos P. Scordilis

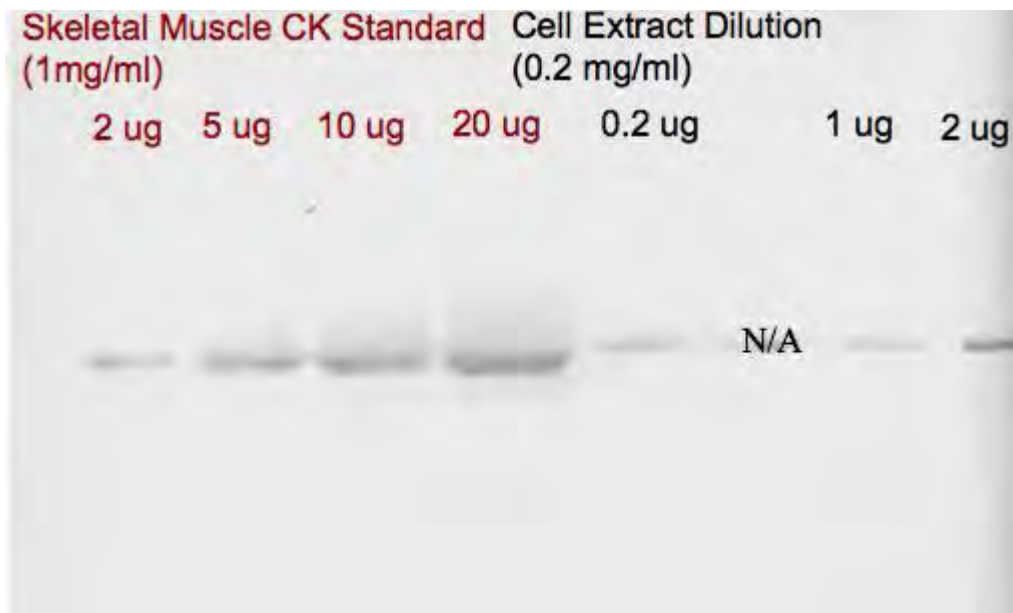

Figure 1. An immunoblot using anti-mouse skeletal muscle creatine kinase antibody. The first four lanes are the standard curve using skeletal muscle creatine kinase, followed by C2C12 cell extracts.

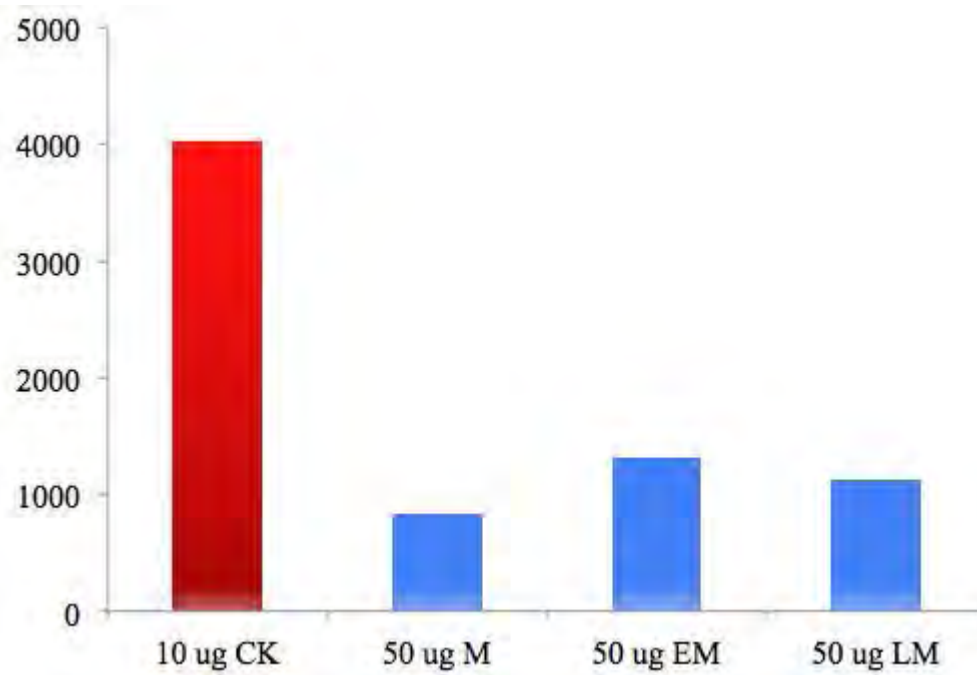

Figure 2. The integrated pixel intensity from an immunoblot using anti-mouse skeletal muscle creatine kinase antibody for 10 μ g skeletal muscle creatine kinase, and 50 μ g of myoblast (M), early myotube (EM) and late myotube (LM) C2C12 cell extracts.

Examining Diversity of *Chilodonella uncinata* in a Spatial and Temporal Context

Carmen M. Hernández

Diversity in microbial lineages is far more expansive than what is found in animal lineages. Within a single microbial species, diversity becomes less focused on morphology but more directed on the genetic level, which can potentially even challenge its classification as a single species.^{1,3} A group of taxa that exemplifies uniformity in morphology but divergence in their molecular profile is the ciliates.² They are characterized by their cilia present in at least one part in its life cycle, genome rearrangement, and nuclear dimorphism, in which they have a somatic macronucleus and a germline micronucleus (the macronucleus is transcriptionally active during most of its lifecycle while the micronucleus is only active during conjugation).² For this project, I worked extensively with the ciliate morphospecies *Chilodonella uncinata* (class: Phyllopharyngea), by examining two regions of its genome, the highly conserved nuclear small subunit ribosomal DNA (nSSU-rDNA) and divergent mitochondrial small subunit ribosomal DNA (mtSSU-rDNA) (up to 8.0%).³ In previous work of the Katz lab, 28 cells of *C. uncinata* were isolated from collecting sites on the Smith College campus and nSSU r-DNA/mtSSU r-DNA sequences were found. Phylogenetic analyses indicated that all sequences clustered with other known sequences of *C. uncinata*, and interestingly enough, for any location at any point in time only there was only one genetic type present.⁴ However there was not an emphasis on how genetic types changed over time in the course of one day. In order to reconcile this lack of information denaturing gel gradient electrophoresis (DGGE) is to be used to detect the genetic types potentially present at any point in time in a particular location. Preliminary work during the summer focused on creating and testing *C. uncinata* specific primers for nSSU r-DNA and mtSSU r-DNA based off alignments from the 28 cells isolated. These primers were then used on extracted DNA from pond water, filtered through 80µm, 10µm, and 2µm filters. Preliminary results via PCR indicated that the primers did work in amplifying the correct size fragment of DNA and a rough analysis of sequences show that targeted organism was in fact *C. uncinata*. Further work is now needed to actually go through the periodic sampling of different locations to see communities of *C. uncinata*. Hopefully these results will show that communities will change over small periods of time and that a more inclusive phylogeny of *C. uncinata* will show more accurately how diverse this morphospecies actually is. (Supported by the National Science Foundation)

Advisor: Laura Katz

References:

¹Finlay B. J. (2004). Protist taxonomy: an ecological perspective. *Phil. Trans. R. Soc. Lond. B.* 359: 599-610.

²McGrath, C., R. Zufall and L. A. Katz. (2006). "Genome Evolution in Ciliates" in *Genome Evolution in Eukaryotic Microbes*, L. A. Katz and D. Bhattacharya, eds. Oxford University Press.

³Katz et al. (2011). Heterogeneous rates of molecular evolution among cryptic species of the ciliate morphospecies *Chilodonella uncinata*. *Journal of Molecular Evolution*.

⁴Palaguachi, Gladys (2012). Our Microbial Planet: Understanding Diversity Through Analyses of Ciliate Morphospecies. Unpublished Undergraduate Thesis. Smith College.

Mill River Invasive Species Mitigation

Brittany Innis

Invasive plants cause extreme stress to native ecosystems. They often easily outcompete their native counterparts due to their ability to grow and reproduce incredibly quickly. Invasive plants are often introduced as ornamentals, and quickly escape cultivation. These aggressive species can cause native plant populations to drop to dangerously low levels, even potentially causing local extinctions. In order to avoid invasive monocultures, the movement to control invasive plant species has grown drastically in the past few decades. Smith College has also been invaded by these aggressive species, especially in the riparian areas along the mill river.

This summer I continued my work fulfilling the Orders of Conditions imposed by the local Conservation Committee in response to the Synthetic Turf Project that occurred two years ago. In collaboration with the Smith College Botanic Garden summer interns approximately 95% of invasive plants in four focus areas surrounding the Mill River on campus were treated or removed. The invasive plants removed included *Rose multiflora* (Multiflora Rose), *Berberis thunbergii* (Japanese Barberry), *Fallopia japonica* (Japanese Knotweed), *Elaeagnus umbellata* (Autumn Olive), *Celastrus orbiculatus* (Oriental Bittersweet), *Euonymus alatus* (Winged Euonymus) and *Acer platanoides* (Norway Maple). Once the removals were complete, I created a map using GIS software to reflect the removed invasive populations. This map, in addition to a final report that includes a future years maintenance plan, will be sent to the Conservation Committee as proof of fulfillment of the Order of Conditions.

As I have worked on this project the past three summers I have learned quite a bit about plant ecology, and the impact invasive species can have on a native population. The numbers of invasive species found each summer have significantly shrunk, and personal observation has led to me to believe that native populations have begun a slow recovery. In the future, this project will include the planting of native species in target areas. This project has also led to multiple projects within the Smith academic community, including an introductory biology class tagging and removing the invasive Norway Maples, and a landscape studies class looking at the possibilities for use of one of the target areas. The removal of invasive species not only encourages the health of a native plant population, but also helps make these areas useable as educational and recreational spaces for the Smith College community. (Supported by the Facilities Synthetic Turf Project and Botanical Gardens Funds)

Advisors: Gary Hartwell and Gaby Immerman

Investigation of Immunogenicity Using Immune-Informatics Software

Jenny Jiang

.....

Lymphatic filariasis, caused by parasitic worms, is a neglected tropical disease that affects millions of people, often poor people in underdeveloped countries. It is the second leading cause of permanent and long-term disability worldwide. I analyzed datasets of proteins secreted in the different life stages of the parasite using membrane topology software like Phobius and SignalP to test how well these programs are at predicting secreted proteins for this organism. The results are shown in Figures 1 and 2.

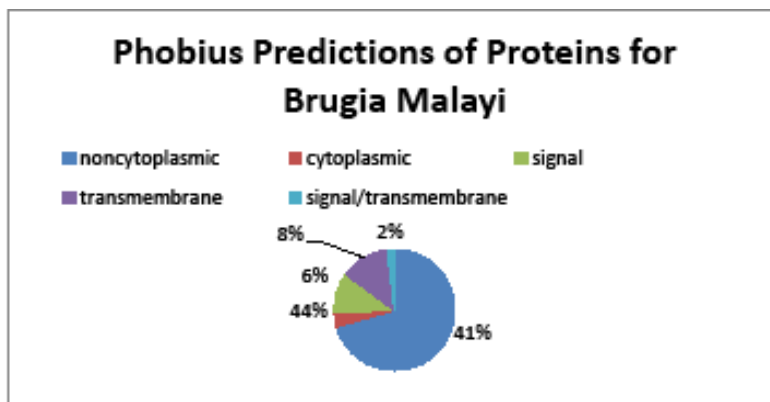

Figure 1. Phobius predictions on all literature cited proteins.

The following chart demonstrates the overall predictions for a total of 974 proteins. These proteins were consolidated from the published work of Moreno & Geary (2008) and Bennuru et al. (2009). The number of proteins within the overall 973 was predicted as follows: 104 signals secreted, 19 signals transmembrane, 126 transmembrane, and 686 non-secreted. Non-secreted proteins were a combination of cytoplasmic and non-cytoplasmic predictions (where non-cytoplasmic could also mean nuclear).

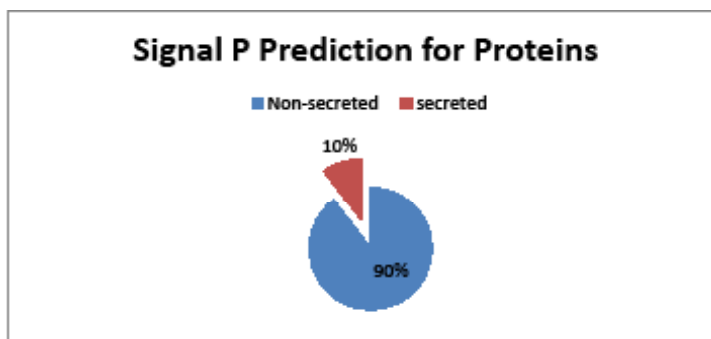

Figure 2. Signal P predictions on all literature cited proteins.

The graph represents the overall predictions for a total of 976 proteins. These proteins were consolidated from the published work of Mereno & Geary (2008) and Bennuru et al. (2009). The number of proteins within the overall 976 was predicted as follows: 101 signal secreted and 875 non-secreted.

As the results differ between the two membrane topology software it cannot be determined if these software can be used to predict protein secretion. Further experimental testing is needed to determine the accuracy of immune-informatics software. (Supported by the Schultz Foundation)

Advisor: Steve Williams

Exploring the Diversity of Sulfate-Reducing Bacteria Diversity in the Avery Brook Beaver Pond Sediments

Rachel Kaminsky

Beavers influence ecosystem dynamics by building dams that retain sediment and organic material. This creates wetlands and modifies nutrient cycling, affecting the character of the water and materials transported downstream. Beaver ponds are biogeochemical hotspots that contain highly unexplored microbial activity and diversity.¹ They contain sulfate-reducing bacteria (SRBs), which reduces sulfate, using it as the final electron acceptor in respiration.² This reduced sulfate facilitates the methylation of mercury, which is a bioaccumulative environmental toxicant.

We conducted a study of the SRB community located in the sediments in a system of beaver ponds in the Avery Brook stream system located in Conway, MA. This subcatchment forms part of the Mill River watershed and drains into the Northampton Reservoir, the main source of drinking water for Northampton.³ This summer, we focused on distinguishing how the SRB community diverges between multiple sites within one pond.

The methods used for sampling the sediments involved the use of a foam board to float out towards the middle of the pond (where we hypothesized more SRB would be located due to the more anoxic nature) and using a five foot-long straw to collect sediment from the sediment-water interface. A previous method involved collecting sediment cores and segmenting off the top three centimeters of the core. Genomic DNA was extracted from the samples using the PowerSoil® DNA Isolation Kit from MoBio Laboratories, Inc. Denaturing gradient gel electrophoresis (DGGE) was performed on bacterial *dsrB* sequences that were amplified using PCR. PCR products of the same length can be separated by DGGE based on nucleotide composition. This approach is useful for creating a genetic profile of environmental communities and can also be used to identify abundant taxa, which is very difficult using other methods given the hyper-diverse nature of sediment environments.⁴ Bands of interest were excised from the gel and sequenced. Bacterial *dsrA* sequences were also amplified using PCR, and cloned into competent cells. A few clones from each sampling site were chosen for sequencing. The sequences derived from DGGE and cloned DNA were entered into the BLAST database to determine their identities. Cloning products were then minipreped and sent to Penn State for sequencing. In addition to molecular techniques, the geochemistry of the beaver ponds is being studied by observing the levels of metals, ions, pH and dissolved oxygen and carbon.

Preliminary data from Sara Sirois' honors thesis as well as BLAST sequences obtained this summer and last summer show that there is a wide variety of sulfate reducing bacteria, many of which are novel and therefore not identifiable at the species level when compared to BLAST. The majority of *dsrA* sequences were derived from members of the Deltaproteobacteria and the Firmicutes. At this point, only one pond has been studied. Further collection of data from more ponds will answer questions regarding the community divergence between different ponds. Plans for the future include isolating both SSU and *dsrA* RNA in order to identify active taxa. We will continue to use DGGE to generate a more comprehensive profile of the pond in this study as well as others in the Avery Brook series. This work will be continued in the 2012-13 school year as an honors project. (Supported by the Howard Hughes Medical Institute)

Advisors: Robert Merritt, Laura Katz, Robert Newton and Steven Williams

References:

¹Naiman RJ, Johnston CA, Kelley JC. Alteration of north American streams by beaver. *Bioscience* 1988 Dec; 38(11): 753-62.

²Stahl DA, Fishbain S, Klein M, Baker BJ, Wagner M. Origins and diversification of sulfate-respiring microorganisms. *Antonie van Leeuwenhoek*. 2002; 81:189-195.

³Fletcher L. The geochemistry of the Avery Brook subcatchment in the Mill River watershed, Conway, MA. Smith.

⁴Teske A, Wawer C, Muyzer G, Ramsing NB. Distribution of Sulfate-Reducing Bacteria in a stratified Fjord (Mariager Fjord, Denmark) as evaluated by Most-Probable Number Counts and Denaturing Gradient Gel Electrophoresis of PCR-Amplified Ribosomal DNA Fragments. *Appl. Environ. Microbiol.* 1996; 62(4): 1405-1415.



Figure 1: DGGE gel exhibiting the SRB community distribution from two sites in a pond (lanes two and three are duplicates of one another).

Testing the Ability of SecretomeP Prediction Software to Predict *Brugia malayi* Secreted/Non-Secreted Proteins.

Djénè Keita

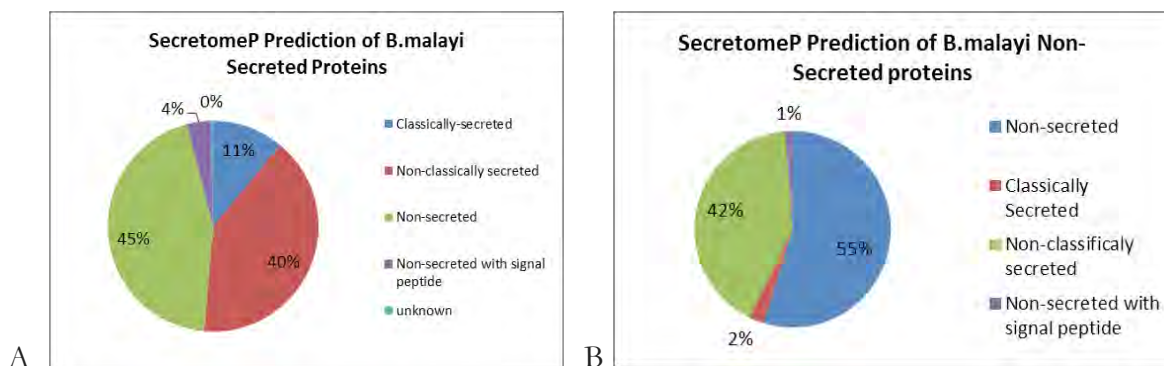

Figure 1A and 1B: SecretomeP predictions of 973 known secreted¹ and 503 non-secreted proteins² of *Brugia malayi*. Protein predictions were classified according to their NN-Score. Classically secreted proteins had an NN-Score ≥ 0.5 with a signal peptide. Non-classically secreted protein predictions had an NN-score ≥ 0.5 . Non-secreted protein predictions had an NN-score of < 0.5 . Non-secreted proteins with a signal peptide had an NN-Score < 0.5 (suggesting membrane proteins). Unknown proteins predictions were the uncharacterized by SecretomeP. Proteins from Figure B within the non-secreted proteins were previously identified as cytoplasmic, nuclear regulation, cytoskeletal, or transcription.

Bioinformatics is a field that uses computer technology to collect, store, analyze and integrate biological and genetic information, which can then be applied to many scientific investigations such as gene-based drug discovery and development. *Brugia malayi* is one of the causative agents of lymphatic filariasis, a tropical disease responsible for incapacitating more than 120 million people in the tropical and subtropical areas of Africa and Asia. Much work involving lymphatic filariasis has focused on analyzing secreted proteins because these proteins are the logical proteins to analyze when looking for highly immunogenic epitopes. This is because it is these secreted/excreted proteins that most readily come in contact with our immune-type cells. The focus of my work was to test the ability of SecretomeP prediction software to predict unknown *B. malayi* proteins by first screening known *B. malayi* secreted/non-secreted proteins cited in previous work on lymphatic filariasis. Accordingly, 973 secreted¹ and 503 non-secreted² proteins were obtained from the published literature. FASTA files of each of these proteins were manually created using Genbank. These files were run through SecretomeP. Of the known secreted proteins, SecretomeP was only able to predict 51% of proteins to be secreted (classically and non-classically)[Figure 1A]. Meanwhile, only 55% of the proteins from the non-secreted data file were predicted to be non-secreted [Figure 1B]. These results indicate that SecretomeP is not a good prediction software to use to predict *B. malayi* secreted and non-secreted proteins because it had a poor rate of prediction rate within each set of known proteins. It is a poor prediction software for *B. malayi* proteins and it cannot be used to either verify known *B. malayi* proteins or classify unknown proteins. (Supported by the Schultz Foundation)

Advisor: Steven Williams

References:

- ¹Bennuru S, Semnani R, Meng Z, Ribeiro JMC, Veenstra TD, et al. (2009) *Brugia malayi* Excreted/Secreted Proteins at the Host/Parasite Interface: Stage- and Gender-Specific Proteomic Profiling. PLoS Negl Trop Dis 3(4): e410. doi:10.1371/journal.pntd.0000410.
- ²Bennuru S, Meng Z, Ribeiro JM, Semnani RT, Ghedin E, et al. (2011) Stagespecific proteomic expression patterns of the human filarial parasite *Brugia malayi* and its endosymbiont *Wolbachia*. Proc Natl Acad Sci U SA 108: 9649–9654.

Species-specific Morphology May Reveal Function of Earless Seal Vibrissae

Caroline D. Keroack and Joy M. Lapsertis

Vibrissae, or whiskers, are specialized hairs found on mammals that are involved in tactile sensation. These hairs are found on various regions of the face, including the lips, eyebrows, and nose. Each hair has a set length and thickness, which may affect the function of the whisker. At the base of each whisker is a special hair follicle connected to neurons, which pick up signals from the environment. In seals, whiskers are concentrated on the face, around the nose and lips, and above the eyes. The earless seals (Phocidae), with the exception of the monk seals, exhibit a unique beaded morphology unlike any other mammalian vibrissae. The frequency and size of the bumps differs among phocid species as well as the appearance and distribution. Phocids do not use echolocation to locate prey, so vibrissae must play an important sensory role. How the bumps functionally effect the vibrissae in phocids remains unclear. In order to understand how these highly specialized whiskers work, detailed morphometrics must be collected and analyzed against behavior ecology.

Data were collected from preserved museum specimens as well as fresh stranded or by-catch seals. General facial measurements were taken as well as specific whisker measurements. The total length of the whiskers was taken, as well as peak-to-peak and trough-to-trough distances, and peak and trough widths. In addition to measurements, the vibrissal arrangement and density were mapped. The maps revealed certain core patterns (Figure I) that are distinct between species. By measuring, counting, mapping, and comparing whiskers across individual and across seals, we hope to ultimately reveal the function of the vibrissae.

Much of the data has yet to be analyzed but some trends are apparent. Clearly the morphology and distribution of vibrissae varies highly between phocid species. This may have some correlation to prey preference and diving behavior. We are also collecting data on these behaviors from the literature, to test for correlations between behavior and vibrissal characteristics. (Supported by the B. Elizabeth Horner Fund in the Biological Sciences)

Advisor: Virginia Hayssen

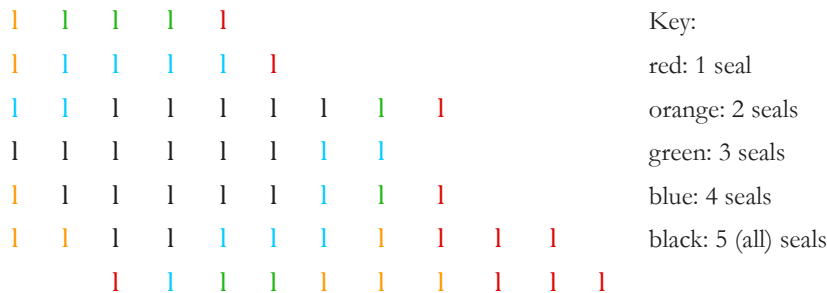

Figure I: (Above) Photograph of left side of face of crabeater seal, maps of the vibrissae were laid out in grids and then overlapped to yield combination maps. Combination map of crabeater seal, left side of map is anterior (1), right is posterior(2), dorsal is the first row(3), and ventral is bottom row(4) (*Lobodon carcingophaga*) vibrissae.

Analyzing the Teratogenic Effects of Macondo Crude Oil on Zebrafish Embryogenesis

Lydia-Rose Kesich

On April 20, 2010, the Deepwater Horizon offshore drilling rig exploded, killing eleven workers, opening a massive, highly pressurized oil leak, and beginning one of the worst environmental disasters in American history. In the five months it took to seal the well, nearly 4.9 million barrels of oil had been introduced to the Gulf of Mexico, resulting in severe and poorly understood deformities of native marine life.¹ Using zebrafish as a model system, our lab has been characterizing developmental defects associated with crude oil exposure. This summer I explored methods by which these defects could be traced back to an interaction between a chemical component of oil and a zebrafish cell signaling pathway.

Microarray analysis measures the differences between levels of gene expression in different tissue samples, in the case of my project, oil-treated embryos and non-oil treated embryos. Each microarray contains tens of thousands of probes, which are short sequences of DNA that will hybridize with an RNA transcript in the sample. Our microarray yielded nearly 40,000 differentially regulated genes, which have to be sorted for significance and matched to a particular phenotype in the oil-treated embryos. This is being done in two ways: by identifying genes that may be a factor in a certain phenotype and looking for them in the microarray results, or by mathematically identifying genes that have an extreme differential between oil-treated and control, and trying to match them to a phenotype.

Oil-treated zebrafish present with several defects described in a previous publication of our lab, including dorsal curvature of the spine, cardiac edema, yolk-sac edema, delayed development, hemorrhaging, and disordered muscle fibers and somites.¹ Our oil-treated zebrafish also have defects in an inner ear structure called the otolith, which in teleost fish primarily contains the protein products of three genes: *starmaker (stm)*, *otolith matrix protein 1 (omp1)*, and *otolin 1*.² After some basic characterization of the defect I searched the microarray results for the presence of these genes and found *stm* and *omp1* to be downregulated in three out of four microarray trials, indicating that the otolith defects have a source in a disrupted genetic pathway and are not the result of chemical stress caused by oil exposure.

Microarray analysis is a useful tool in characterizing our already-described phenotypes. The microarray allows me to look for genes that I suspect are misregulated, and is much more time- and cost-effective than performing immunohistochemistry or *in situ* hybridization to look for differential regulation of every gene that may possibly play a role. This will be an essential tool in my attempts to describe the causes of the muscle phenotype. In the future I hope to do interactome analysis, which identifies connections between misregulated genes and helps to reconstruct broken cell-signaling pathways. (Supported by the B. Elizabeth Horner Fund in the Biological Sciences)

Advisor: Michael Barresi

References:

¹De Soysa et al. 2012. Macondo crude oil from the Deepwater Horizon oil spill disrupts specific developmental processes during zebrafish embryogenesis. *BMC Biology* 10:40.

²Petko et al. 2008. *Otoc1*: a novel otocon-90 ortholog required for otolith biomineralization in zebrafish. *Dev Neurobiol.* 68:209-222.



To Characterize Sulfate-Reducing Bacteria in Avery Pond

Nida Khan

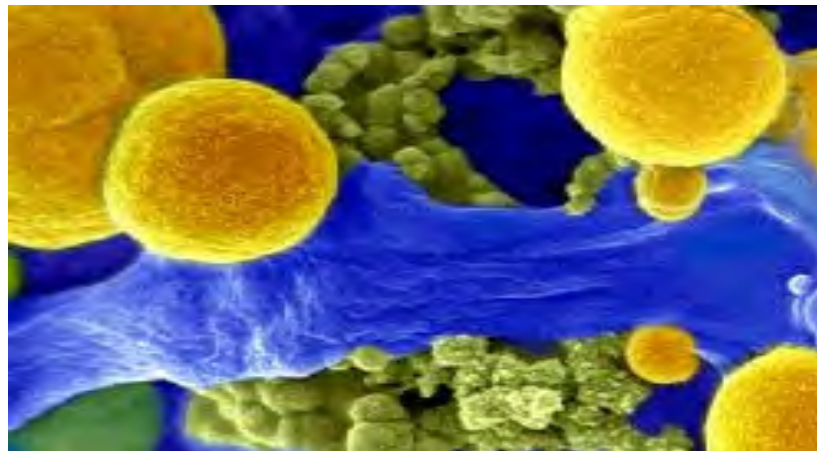

Figure 1. Sulfate-reducing Bacteria

The purpose of this project was to characterize sulfate-reducing bacteria in Avery Pond, which is a beaver pond, located in Massachusetts. Sulfate-reducing bacteria are responsible for the methylation of mercury, which is a bioaccumulant. These bacteria have the enzyme dissimilatory sulfate reductase which uses sulfate as an electron acceptor in anaerobic respiration. By studying the *dsrAB* gene, which codes for the enzyme dissimilatory sulfate reductase, I could identify the microorganisms responsible for sulfate reduction and therefore, create a profile of the sulfate-reducing bacteria in the pond.

In order to create this profile, DNA was isolated from soil samples from the pond using the MO Bio kit. The sample then underwent PCR and gel isolation to determine whether any sulfate reducing bacteria were isolated from the sample. This was done so that I could confirm the presence of DNA and proceed to sequence the DNA. However, much time was put in to determining a protocol that effectively allowed for the isolation of DNA from the soil samples with fewer impurities. Towards the end of the summer, I started focusing on RNA as opposed to the DNA in the soil samples. Many bacteria may have the *dsrAB* gene, but this gene may not necessarily be expressed. Therefore, by focusing on isolating RNA from the soil samples, I could create a profile of bacteria that are actively expressing the *dsrAB* gene. RNA isolation proved to be more of a challenge due to the possibilities of RNase degradation, low RNA yields and impurities. (Supported by the Blakeslee Fund in the Biological Sciences)

Advisor: Robert Merritt and Laura Katz

What's Your Orientation: Long PCR Analysis of the Xq28 Region

Cait Kirby

On the XQ28 region of the X chromosome there are two genes flanked by two repeat regions. The orientation of these genes and repeat regions is variable, with 33% of females presenting as heterozygous. (Small et al) The two genes that exist in this region, emerin and filamin, serve to produce muscle and structural tissue. If any part of the emerin gene is deleted a patient could have muscular dystrophy; if any part of the filamin gene is deleted, the embryo is inviable. Emerin, 2kb in length, and filamin, 26kb long, are sandwiched between two 11.3kb repeat regions which have 99% sequence identity (Small et al). Inversions inhibit recombination via less frequent crossing over, which contributes to speciation (Small et al).

The goal of this project is to design a teaching lab to provide students with a hands-on learning opportunity to understand concepts such as crossing over, recombination, and linkage disequilibrium. This teaching lab will also give students an opportunity to delve into lab work, including DNA extraction, PCR, and gel electrophoresis. In designing this experiment I used information from scientists at Emory University who provided us with primer sequences, and a PCR program. After determining novel DNA extraction methods, the PCR began to work, though inconsistently. After deciding to add DMSO (to improve denaturation of G-C rich regions) and BSA (to bind up inhibitors) both of which are purported to enhance the efficiency of PCR, we became successful, though still rather inconsistently.

The goal of this project is to produce a presence-absence assay allowing us to quickly and easily determine in which orientation a student's genes lie. The primers that we were provided produce two different sized bands, the forward orientation results in an 11kb band, while the inverted orientation results in a 12kb band. The difference is slight, and typically not discernible, but I will still attempt to multiplex the PCR – putting both assays into one reaction – providing us with one quick answer instead of two separate reactions. (Supported by the Nancy Kay Holmes Fund)

Advisor: Robert Merritt

References:

Small, Iber & Warren. Emerin deletion reveals a common X-chromosome inversion mediated by inverted repeats. *Nat Genet.* 1997 May ;16(1):96-9.

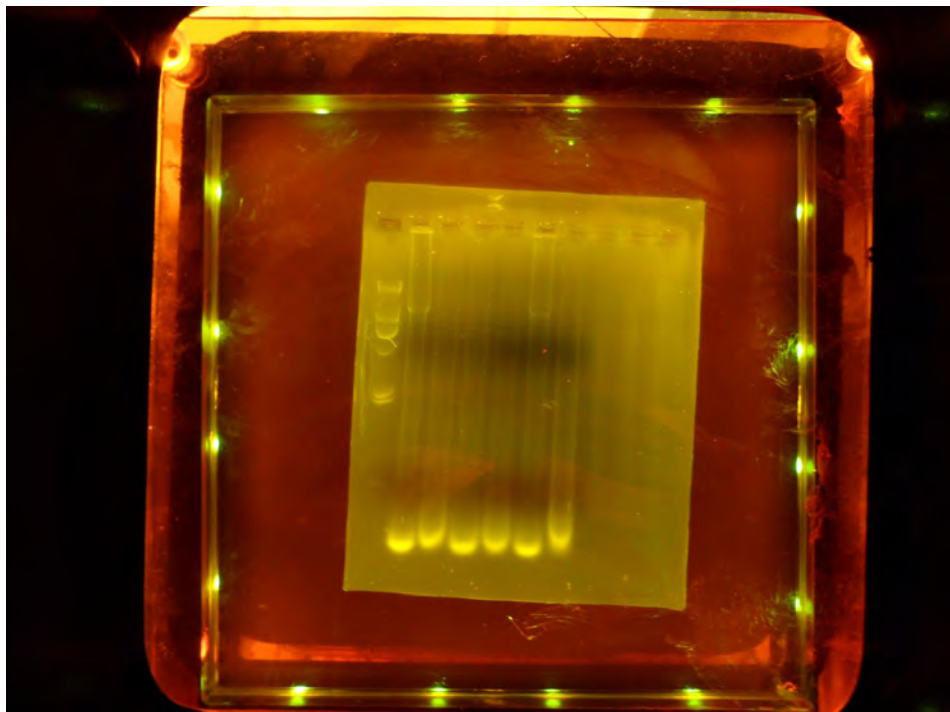

Influence of Body Size on Reproductive Trends in Canids (Canidae)

Elissa Larabee

Thirty-five extant species of canids currently comprise the family Canidae, a predominately carnivorous group that includes wolves, foxes, and domesticated and wild dogs. Morphological characteristics such as body mass, head body length, hind foot length and ear length vary across species. Reproductive variances in litter size, gestation length and lactation length also occur.

In an effort to better understand the relationship between body size and the reproductive trends of canid species, quantitative data (ie: body mass/length, ear/hind foot length, average litter size of an individual, neonatal mass, gestation and lactation length) was collected from previously conducted studies and regression analysis was done to discern what, if any, allometric relationships exist. Data from past STRIDE students was combined to create a consistent data set. For the summer 2012 SURF project, the data set was updated by retrieving data from primary sources from 2010 to 2012.

Following regression analysis of all compiled data a positive correlation was found to exist between neonatal mass and adult female mass, as well as litter size and adult body mass. In general, no relationship was found to exist between lactation or gestation length and adult body size. Furthermore, no energetic benefit seemed to be present in regards to temporal trade-offs between gestational and lactation length, indicating that both reproductive processes are in fact independent variables in regards to body size of canids.

Gestation length is believed to have a minimum time requirement needed to produce a viable birth that was consistent among all species of canids, while lactation length was shown to be more variable.

This research is currently ongoing, more investigation into specific outliers (*Canis Lupus* and *Chrysocyon brachyurus*) is needed to determine what factors may influence certain inconsistencies in their reproductive trends in respect to other canid species. (Supported by the B. Elizabeth Horner Fund in the Biological Sciences)

Advisor: Virginia Hayssen

Temperature-Dependent Regulation of Fimbrial Phase Variation in *E. coli*

Da Yae Lee

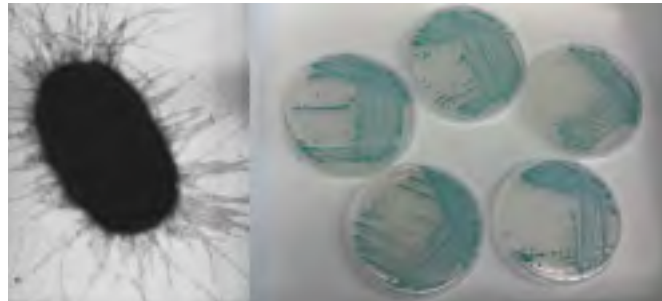

Source: rehydrate.org

How does temperature act as an environmental cue to elicit genotypic and phenotypic responses in bacteria? This summer, as part of my continuing research in the White-Ziegler lab on the effect of thermoregulation in *Escherichia coli*, I examined the dependence of phase variation [P/V] in its fimbrial operons on the temperature of growth. For *E. coli* strains capable of intestinal or extraintestinal infections, fimbriae are essential colonization and virulent factors, aiding in bacterial adhesion to and invasion of host epithelial cells.¹ As energy-expensive as it is to make fimbriae, fimbrial adhesions are tightly regulated in part by phase variation, or the reversible switching of phenotypes based on protein expression to generate a heterogenic population.²

For this study involving transcriptional lac fusions of five *E. coli* fimbrial operons (*fan*, *pap*, *daa*, *sfa* and *fim*), two models of thermoregulation were tested: does temperature act as a precise switch that turns on or off an operon at a defined degree (°C), or does it gradually modulate the amount of fimbrial operon transcripts with changing temperature (observed by a change in the intensity of blue color of the colonies)? For the experiment, *E. coli* K-12 strain was grown overnight on five M9 X-gal plates at 37°C, each plate inoculated with a colony of a different fimbrial operon-lac fusion. Of these control colonies, one darkest blue colony (blue representing P/V ON; white representing P/V OFF) was streaked onto four new X-gal plates, each then incubated at a new temperature (30, 29, 27 and 25°C). Once full-sized colonies had grown, the plates were observed for two notable features: (1) how does the intensity of blue colonies compare to those on other plates and, (2) what is the temperature (if at all) at which the operon completely turns off?

The *fan* operon, which is known not to be phase variable, served as the negative control. Across all temperatures, all *fan*-lac colonies of the clonal population were blue. At 25°C, however, all colonies were white, indicating the gene was turned off. Of the four known phase-varying operons—*pap*, *daa*, *sfa*, and *fim*—*pap*- and *daa*-lac expressing colonies responded to decreasing temperature with a decreasing intensity of blue, whereas *sfa* and *fim*-lac expressing colonies did not show a sign of intensity change. A common feature was all four phase-varying fimbrial genes seemed to turn off completely by 25°C, producing all-white colonies. The results suggest that P/V is turned OFF somewhere between 27 and 25°C. As for the two models of temperature regulation proposed, both appear to be at work but affecting different genes. Further studies will attempt to define the critical temperature at which fimbrial operons are turned off. Also genotypic data using qRT-PCR and microarrays will be used to confirm these phenotypic results, to describe how temperature modulates the shift from a less virulent (without fimbriae) to virulent (with fimbriae) lifestyle. (Supported by the National Institute of Health)

Advisor: Christine White-Ziegler

References:

¹Hacker, J. 1992. Role of fimbrial adhesins in the pathogenesis of *Escherichia coli* infections. *Canadian Journal of Microbiology*, 38(7): 720-7.

²Van der Woude, M. W., Bäumlér A.J. 2004. Phase and antigenic variation in bacteria. *Clinical Microbiology Review*, 17 (3): 581-611.

HSP25 Immunoprecipitation from C2C12 Skeletal Muscle Cells

Claire Maesner

.....

Immunoprecipitation is a technique that utilizes the high affinity of an antibody for an antigen to purify a target protein from a highly complex solution, even a cell culture extract. This strategy was used to specifically isolate heat shock protein 25, a molecular chaperone protein involved in the cellular stress protection mechanisms, out of cells from the C2C12 murine skeletal muscle cell line. A direct immunoprecipitation was accomplished employing an anti-HSP25 antibody to isolate the desired protein. Running the sample on a one dimensional SDS polyacrylamide gel confirmed the isolation of the target had been successful (Figure 1, lanes 1-3 within the red box). A purified HSP25 standard is in lane 5, after the molecular weight ladder in lane 4. Following this accomplishment, the immunoprecipitation technique is being modified to pull down and identify the target's associated proteins, thus further revealing its physical interactions with other proteins within these skeletal muscle cells. (Supported by the Howard Hughes Medical Institute)

Advisor: Stylianos P Scordilis

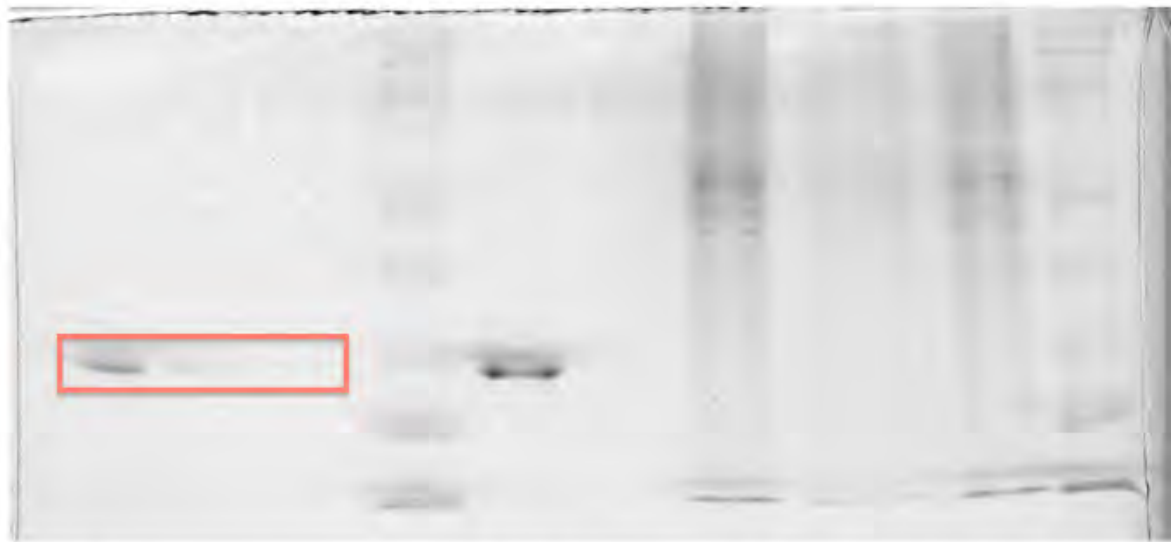

Figure 1: Successful precipitation of the HSP25 protein shown in the first three columns from the left. These samples match the molecular weight of the standard protein (run after the molecular weight ladder) and fall at 25 kDa. Subsequent columns from the left show the lysate sample after the immunoprecipitation, the antibody coupling confirmation, and the original lysate sample.

The Function of the Tail in Aquatic and Semiaquatic Mustelids

Paula Noonan

Otters and mink, members of the Mustelidae family, occupy aquatic and semiaquatic niches. The pertinent question is: “Why did some mammals become aquatic in the first place?” (Reidenberg 2007). The answer is the key source of energy: food available in the aquatic habitat. The adaptations for swimming for these mustelids differ in terms of thrust (amount of webbing of the feet for paddling) and propulsion (amount of undulation of the body and tail). At the same time, mobility on land is somewhat hindered by morphological adaptations for aquatic life, such as webbed feet (Estes 1989). But is the length of the tail significant in an aquatic environment as these otters and mink search for prey? Does the use of the tail by the truly aquatic sea otter differ from that of the freshwater otters or the semiaquatic mink? Specifically, would a longer tail in relation to the body length be a help or a hindrance in an aquatic environment?

One way to look at the function of the tail is to determine what its proportion is to the length of an animal’s body. This type of morphological information exists on the skin tags of specimens in natural history museums and provided the data needed for the sea otter, *Enhydra lutris*; the freshwater otters, *Aonyx capensis*, *Aonyx cinerea*, *Hydrictis maculicollis*, *Lontra canadensis*, *Lontra felina*, *Lontra longicaudis*, *Lontra provocax*, *Lutra lutra*, *Lutra samatrana*, *Lutrogale perspicillata*, and *Pteronura brasiliensis*; and two mink, *Mustela lutreola* and *Neovison vison*. Specimen data came from the American Museum of Natural History in New York, the Field Museum in Chicago, the Smithsonian National Museum of Natural History in Washington, D.C., the ARCTOS and MCZBase databases, and the primary literature. Male (n=617) and female (n= 455) data were separately calculated to control for sexual dimorphism.

Most otters and mink have tails that are 38-76% of the length of their bodies, with the two mink species on the lower end of this range (see Figure 1). However, the sea otter, the only mustelid that spends nearly its entire lifetime in the water, has a tail length of 23% of its body length.

A possible explanation for varying lengths of tails for these species may result from environmental adaptations. Entirely aquatic, sea otters have the most modified feet for swimming, making them awkward on land. When the sea otter is on its back, it may use its tail to maneuver slowly, but in normal swimming position and when swimming submerged, the tail and forepaws are not used in propulsion. Intermediate examples might include the small-clawed otter (*Aonyx cinerea*), the river otter (*Lontra canadensis*), and especially the giant otter (*Pteronura brasiliensis*), which have webbed feet but undulate their tails for propulsion (Borgwardt and Culik 1999; Fish 1994, 2000). Mink have minimal webbing, but maintain a streamlined body similar to the otters (Williams 1989).

If thrust is generated by the tail for some of these species, why would the sea otter have a much shorter tail? The sea otter’s adaptation for a fully aquatic lifestyle appears to show a trade-off between the efficiency of large, webbed feet against the potential undulatory thrust of a longer tail. If a shorter tail works best for sea otters, is there a trend for the freshwater otters to be intermediate in length and the mink (as the most land-based) to have the longest tails? Since mink are not truly reliant on an aquatic habitat, unlike the otters, one might conclude that their morphological adaptations show less modification. However, as the results in Figure 1 show, since the mink have shorter tails than the freshwater otters, the question becomes whether a short tail may be the original trait and a longer tail the derived trait. Further investigation of the relative tail lengths of other mustelids may provide the answer. (Supported by the Elizabeth B. Horner Fund in the Biological Sciences)

Advisor: Virginia Hayssen

References:

- Borgwardt, N., and B. M. Culik. 1999. Asian small-clawed otters (*Amblonyx cinerea*): resting and swimming metabolic rates. *Journal of Comparative Physiology B* 169: 100-106.
- Estes, J. S. 1989. Adaptations for aquatic living by carnivores. In J. L. Gittleman, ed., *Carnivore Behavior, Ecology, and Evolution*. New York: Cornell University Press, pp. 242-282.
- Fish, F. E. 1994. Association of propulsive swimming mode with behavior in river otters (*Lutra canadensis*). *Journal of Mammalogy* 75(4): 989-997.
- Fish, F. E. 2000. Biomechanics and energetics in aquatic and semiaquatic mammals: platypus to whale. *Physiological and Biochemical Zoology* 73(6): 683-398.
- Reidenberg, J. S. 2007. Anatomical adaptations of aquatic mammals. *The Anatomical Record* 290: 507-513.
- Williams, T. M. 1989. Swimming by sea otters: adaptations for low energetic cost locomotion. *Journal of Comparative Physiology A* 164:815-824.

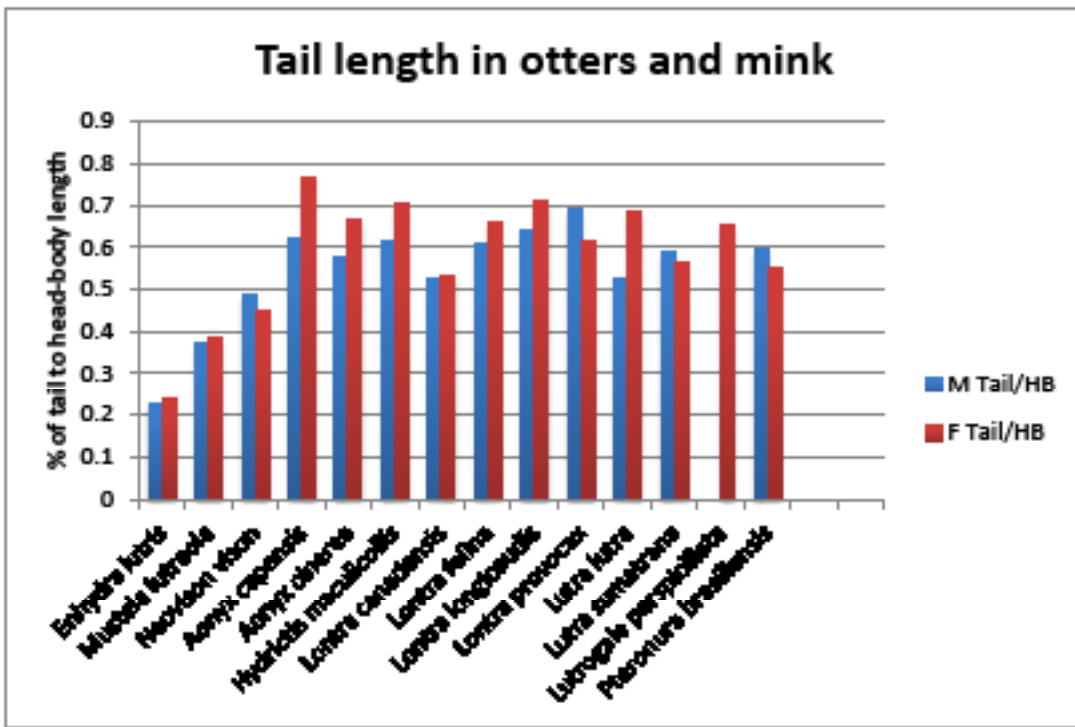

Figure 1. The percent of tail length to head-body for the sea otter, *Enhydra lutris*; two mink, *Mustela lutreola* and *Neovison vison*, and the freshwater otters, *Aonyx capensis*, *Aonyx cinerea*, *Hydricitis maculicollis*, *Lontra canadensis*, *Lontra felina*, *Lontra longicaudis*, *Lontra provocax*, *Lutra lutra*, *Lutra samatrana*, *Lutrogale perspicillata*, and *Pteronura brasiliensis*.

Radial Glia Vital for the Proliferation of Glia and Neural Populations in the Zebrafish Neural Tube

Deborah Ok

Radial glia are neural stem cells that grow into other types of glia and neurons in the lumen of the neural tube. To better understand how important radial glia are for the maintenance of the nervous system, we performed a study on zebrafish with mitotically inhibited radial glia. We collected data on how much cell death occurred over the course of development among radial glia as well as different glia populations such as oligodendrocyte precursor cells. We also wanted to know if the radial glia were accumulating in the lumen over time or dying off. We used a mutant zebrafish line with a knock down of *eg5* (3112a). *Eg5* is a protein essential for the mitosis of radial glia and STLC treated embryos which imitate the mutants' phenotype inhibit radial glia from dividing into other cells. Heterozygous embryos do not express the effects of the *eg5* protein were used as the control. This study of neural stem cells and their targeted inhibition can further our understanding of their role in the nervous system and contribute to regenerative medicine and cancer studies. (Supported by the Howard Hughes Medical Institute)

Advisor: Michael Barresi

Thermoregulation of Various Genes in *Escherichia coli* K-12 at an Intermediate Temperature

Jaclyn Perreault

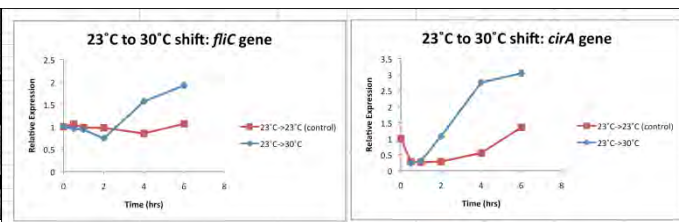
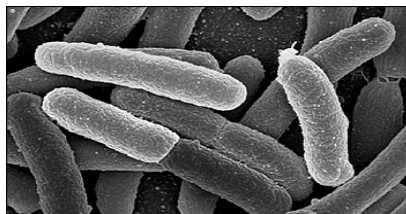

<http://www.bnl.gov/bnlweb/pubaf/pr/photos/2009/10/eColi-350px.jpg>

Temperature is an important regulator of pathways crucial to bacterial survival and colonization of both host and external environments.^{1,2} This project tested the effect of a 30°C environment, an intermediate temperature between room (23°C) and body temperature (37°C), on gene expression in *Escherichia coli* K-12 to investigate at what temperature certain genes turn on prior to host entry.

Previous research shows increased expression of genes involved in acquisition and utilization of iron, carbohydrates and amino acids upon shifting into a 37°C environment.¹ To investigate the expression of genes involved in motility, biofilm formation, iron acquisition, and anti-bacterial defense at 30°C, *E. coli* K-12 (MG1655) was shifted to 30°C temperature after 45 minutes of growth at 23°C in M9 glycerol media. Samples were obtained as the bacteria entered exponential phase (roughly an O.D. of 0.2-0.4) after growth at 30°C for 0.5, 1, 2, 4, and 6 hours. Using Quantitative RT-PCR, gene expression levels were compared for each time point between *E. coli* grown at 23°C and *E. coli* shifted to 30°C. Thermoregulated genes, *ompT*, *fliC*, *csgA*, and *cirA* as well as the non-thermoregulated control, *fur*, were tested.

Less than two-fold change in relative expression levels occurred for *ompT* (encoding an outer membrane protease¹) and *csgA* (encoding the major subunit for curli in biofilm²), while roughly two-fold increase occurred in *fliC* (encoding flagellin, the major flagellar subunit³) and *cirA* (encoding an outer membrane porin involved in iron acquisition¹) by six hours. These results suggest that 30°C temperature does not prompt the increased production of defensive outer membrane proteases (through *ompT*) that was observed at 37°C¹; nor it is sufficient to decrease biofilm formation through any biologically significant drop in *csgA* production. Perhaps continued curli production for biofilm is advantageous for surface adhesion prior to immersion in the 37°C host environment. The results also suggest that a temperature shift to 30°C is enough to prompt flagellar synthesis and activate iron acquisition systems; it may be advantageous to have these systems in place when approaching a host prior to entry.

This project will be continued as a Special Studies in Fall 2012. Future research can explore other genes involved in host environment adaptation, as well as other intermediate temperatures between 23°C and 37°C. Further research will also utilize microarray techniques to gain a greater whole-genome picture of the gene expression changes occurring at intermediate temperatures. (Supported by the National Institutes of Health)

Advisor: Christine White-Ziegler

References:

- ¹White-Ziegler, C. A., A. J. Malhowski, and S. Young. 2007. Human body Temperature (37°C) Increases the Expression of Iron, Carbohydrate, and Amino Acid Utilization Genes in *Escherichia coli* K-12. *J. Bacteriol.*, 189:5429-40.
- ²White-Ziegler, C. A., S. Um, N. M. Perez, A. L. Berns, A. J. Malhowski, and S. Young. 2008. Low temperature (23 {degrees}C) increases expression of biofilm-, cold-shock- and RpoS-dependent genes in *Escherichia coli* K-12. *Microbiology*, 154:148-66.
- ³NCBI Gene Database. 2012. *fliC* flagellar filament structural protein (flagellin). Available at <http://www.ncbi.nlm.nih.gov/gene/949101>. Accessed 18 August 2012.

Generating Images of Swarming Motility Across Strains of *Escherichia coli*

Shannon Pettit

Swarm motility assays conducted as part of my honors project revealed differences in the swarming motility of *E. coli* across different strains, temperatures, and types of growth media. These analyses of motility provide a phenotypic comparison for gene expression data generated in the White-Ziegler laboratory. Recent microarray data from our lab has shown that genes involved in flagellar motility are down-regulated in a 37°C to 23°C transition for the non-pathogenic K-12 strain MG1655, while qRT-PCR data indicates that those same genes show increased expression after a 23°C to 37°C upshift. These gene expression patterns are not conserved across strains, where uropathogenic strain CFT073 demonstrates decreased motility gene expression after a 23°C to 37°C temperature shift.

To generate images that support the phenotypic motility data, reduced-agar swarm motility plates were prepared and inoculated with the three strains of interest and a negative control. Images were taken of these plates at specific times after inoculation. These images were taken with illumination from below with indirect white light in a covered environment to minimize glare.

These images support our previous findings that there are differences in motility based on strain and environmental conditions that include ambient temperature and the nutrient richness of the growth media. Uropathogenic strain CFT073 was motile in all media and temperature conditions, while enteropathogenic strain E2348/69 and K-12 strain MG1655 are more sensitive to environmental conditions. These two strains show high levels of motility on nutrient rich media, but minimal or no motility on a nutrient poor medium (Figure 1).

The importance of these images is how they support the previously generated swarm motility data described in my honors project, which I presented in poster form at the American Society of Microbiology 2012 Annual Meeting in San Francisco, CA. They will be used in a publication alongside the data to further describe the effects of ambient temperature shifts on the gene expression and morphology of *E. coli*. (Supported by the Blakeslee Fund in the Biological Sciences)

Advisor: Christine White-Ziegler

Figure 1: Swarm Motility of MG1655 Across Temperatures and Growth Media

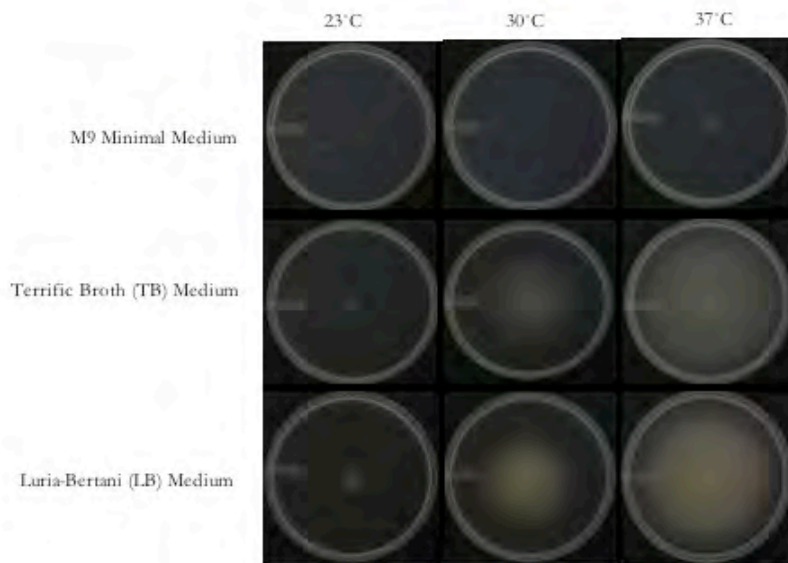

Variation in Mustelid Hind Foot and Tail Length

Siobhan Prout

As the behaviors and environments of animals vary, the animals evolve and adapt so that form meets function. One family of animals may present a wide range of body sizes and designs, which is the case in the family Mustelidae. Although commonly referred to as weasels, members of the family include badgers, martens, and otters. In fact, Mustelidae is the world's largest family of carnivores. Two distinct members of Mustelidae are badgers, with ten species in five genera (Fig. 1), and martens, with three species in genus *Martes* (Fig. 2). I compared morphological data with behavior in these two groups to find a relationship between hind foot length, tail length, and behavior, such as how much time they spend in trees or on the ground digging. I compared badgers to martens because although they are all mustelids, they live in different environments and therefore their hind feet and tails serve different purposes. I expected to find that the partially arboreal marten has a longer hind foot and tail than the terrestrial badger because the marten divides its time between the ground and trees, which they climb for protection, to hunt, and sometimes to make dens in hollow trunks.¹ Their bodies are designed for these activities, with hind feet long enough to curve to grip branches, and a tail that provides extra balance when climbing.² Because badgers are diggers that rely on their forefeet to burrow through soil,³ I expected that their hind feet and tails would be shorter so as not to be a hindrance to digging.

For each species, I took the weighted average for hind foot length and divided it by the weighted average of head-body length so I could compare the hind feet length of different species relative to their body sizes. I used the same method to find the ratio of tail length to head-body length. The sample sizes for each species of *Martes* were as follows: *Martes americana*, hind foot, n149, tail, n167; *Martes flavigula*, hind foot, n90, tail, n109; *Martes foina*, hind foot, n59, tail, n66; *Martes martes*, hind foot, n163, tail, n245; *Martes melampus*, tail, n2; *Martes pennanti*, hind foot, n56, tail, n64; and *Martes zibellina*, hind foot, n17, tail, n4. The sample sizes for each species of badger was as follows: *Arctonyx collaris*, hind foot, n17, tail n30; *Meles anakuma*, hind foot, n1, tail, n2; *Meles leucurus*, hind foot, n3, tail, n30; *Meles meles*, hind foot, n18, tail, n26; *Mellivora capensis*, hind foot, n6, tail, n8; *Melogale everetti*, hind foot, n14, tail, n14; *Melogale moschata*, hind foot, n43, tail, n45; *Melogale orientalis*, hind foot, n12, tail n13; *Melogale personata*, hind foot, n39, tail, n39; and *Taxidea taxus*, hind foot, n443, tail, n464.

Overall, martens have longer tails and longer hind feet than badgers. The average ratio for tail length to body length in martens (Fig. 3) was 16.4% greater than the average ratio for badgers (Fig. 4) (0.601, 0.321). The average ratio for hind foot length to body length in martens was 46.6% greater than the average ratio for badgers (0.201, 0.168).

Overall, the data support the idea that the marten, a tree-climber, has a longer hind foot and tail than the badger, a digger. The ratios for all species of martens were similar with little variation between males and females. Even when a species spends more time in open areas than in trees, such as *Martes foina* compared to *Martes martes*, length differs only slightly. The ratios for the badgers were much more varied, most notably in the tails of genus *Melogale* and the hind feet of *Mellivora capensis*. These badgers are known to climb trees to hunt,^{3,4} which may be why their ratios are similar to those of the martens. Over the past year, a graduate student and I have worked to collect data on body size and reproductive habits in mustelids. We plan to spend the next two semesters using our compiled data to further explore relationships among species within the large and varied family of Mustelidae. (Supported by the B. Elizabeth Horner Fund in the Biological Sciences)

Advisor: Virginia Hayssen

References:

- ¹Dublin, L. L. 1903. Adaptations to aquatic, arboreal, fossorial and cursorial habits in mammals. *The American Naturalist*, 37: 731-736.
- ²Larson, S.G. and J.T. Stern. 2006. Maintenance of above-branch balance during primate arboreal quadrupedalism: Coordinated use of forearm rotators and tail motion. *American Journal of Physical Anthropology*, 129: 71-81.
- ³Van Valkenburgh, B. 1987. Skeletal indicators of locomotor behavior in living and extinct carnivores. *Journal of Vertebrate Paleontology*, 7: 162-182.
- ⁴Storz, J.F. and W.C. Wozencraft. 1999. *Melogale moschata*. *Mammalian Species*, 631: 1-4.

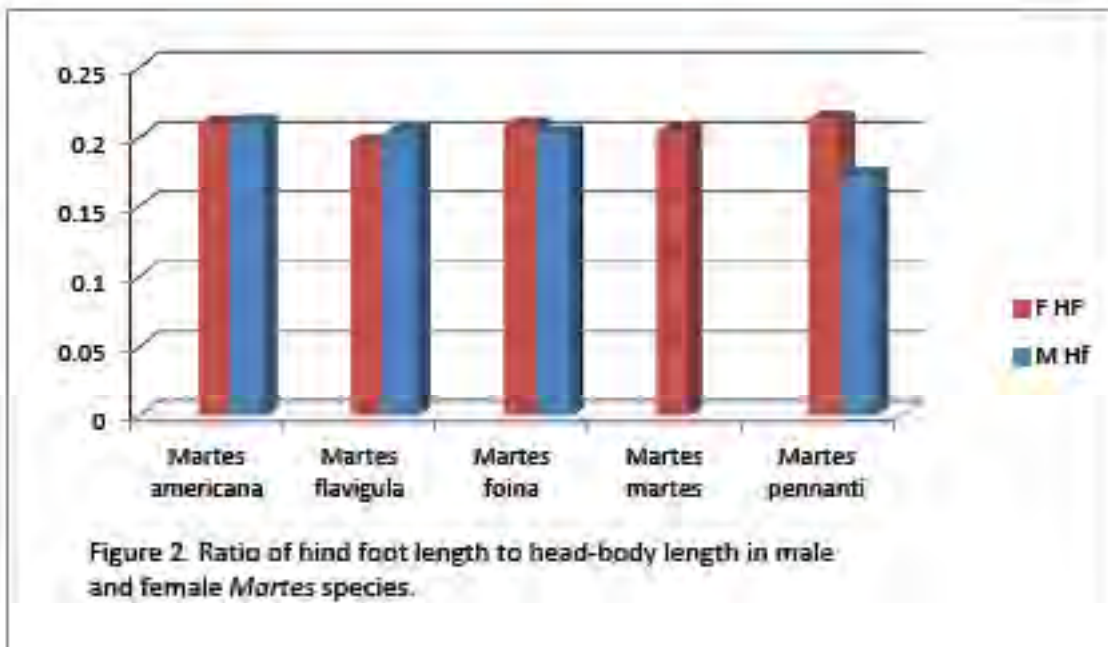
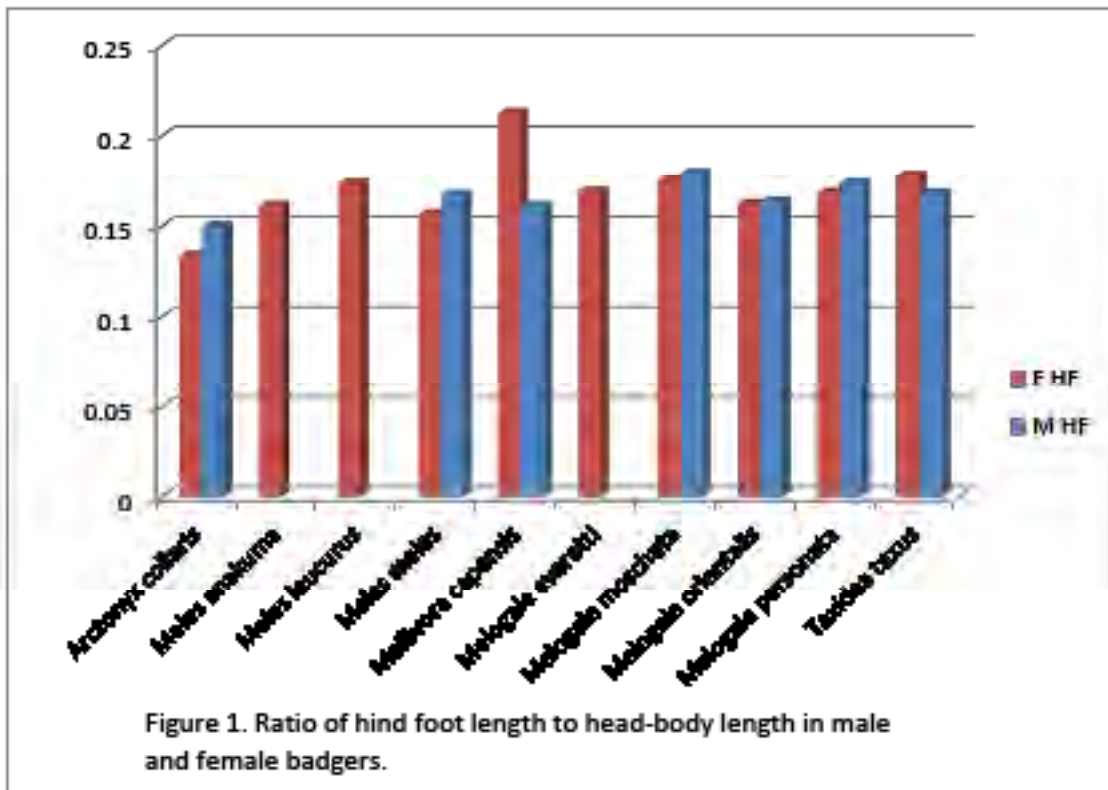

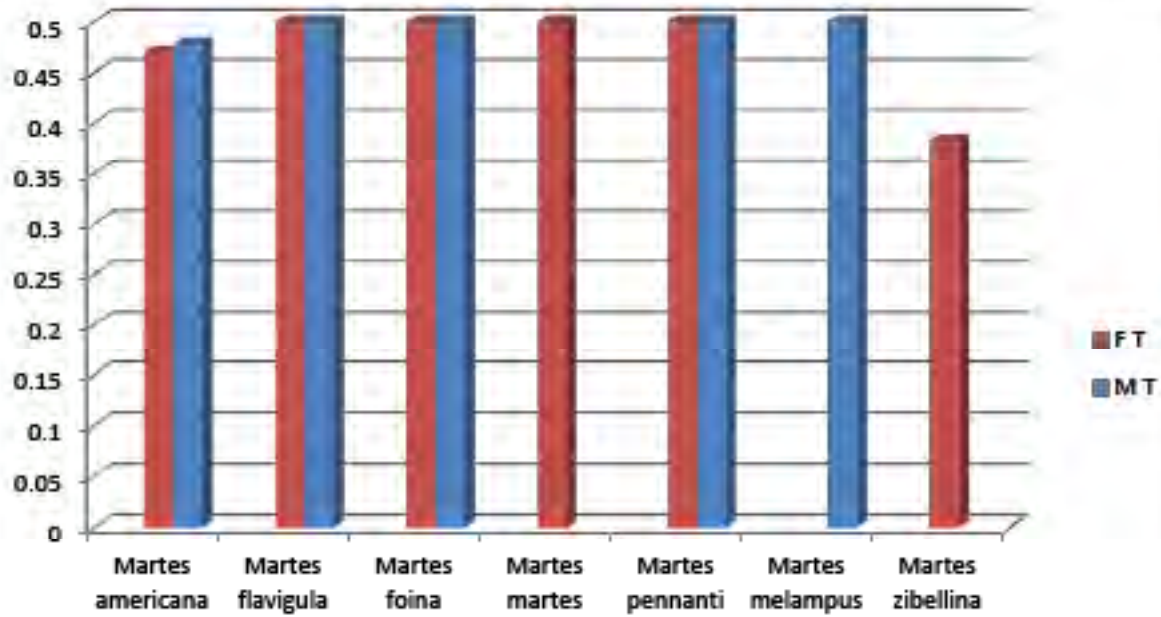

Figure 3. Ratio of tail length to head-body length in male and female *Martes* species.

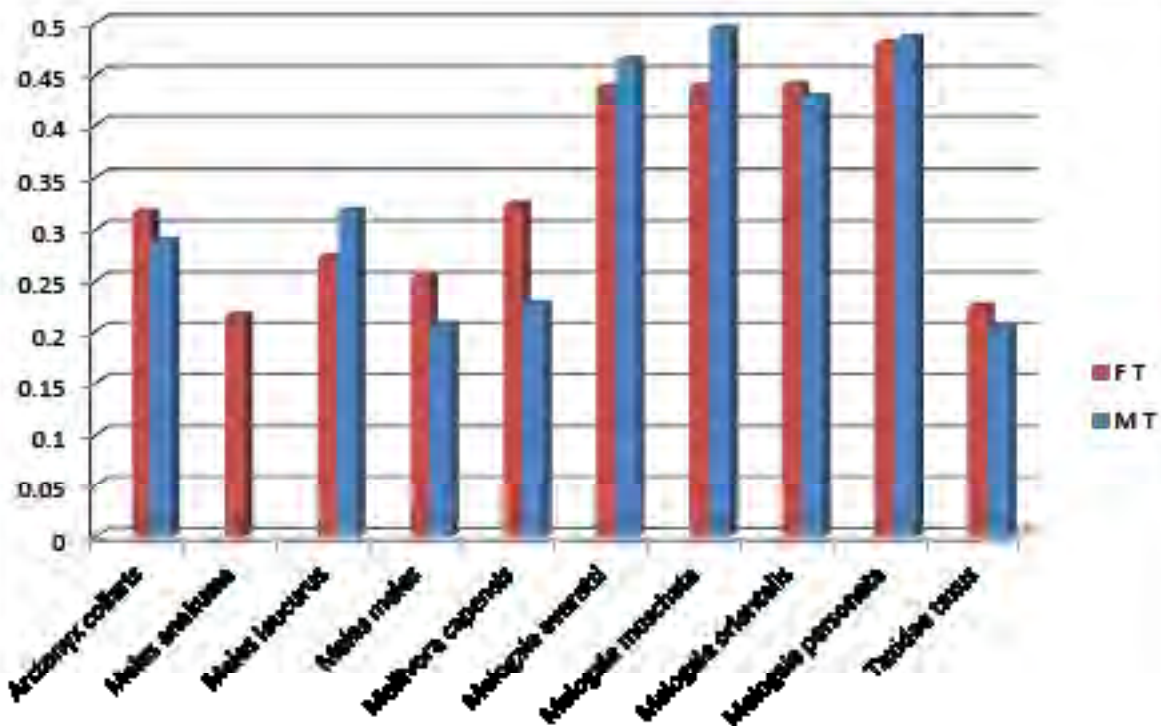

Figure 4. Ratio of tail length to head-body length in male and female badgers.

Identification of *pdf-1* as a Functional Circadian Clock Gene in *Brugia malayi*

Johanna Ravenhurst and Jenna Wurster

The aim of this ongoing project is to correctly identify and isolate a functional circadian clock gene in the parasite *Brugia malayi*; with the hope that said gene would act as a novel drug target to combat lymphatic filariasis. Lymphatic filariasis (LF) is the result of a parasitic infection from the filarial nematodes: *Brugia malayi*, *Brugia timori* and *Wuchereria bancrofti*.¹ LF causes lymphedema and elephantiasis, and has left over 43 million people officially disabled.² In response, the World Health Organization has organized the Global Programme to Eliminate Lymphatic Filariasis (GPELF); the goal of which is to eradicate LF as a public-health problem by 2020.¹

Previous work has narrowed down a candidate circadian clock gene, pigment dispersing factor receptor (*pdf-1*), via BLAST search results of both nucleotide and protein sequences. These search results have shown that a particular *Brugia malayi* sequence has over ninety percent sequence similarity to the *Caenorhabditis elegans*' *pdf-1* sequence, indicating potential homology between the two genes. With this idea in mind, experimental design has been centered around proving the unidentified *B. malayi* gene possess the same function as *C. elegans pdf-1*. Additional work done prior to summer 2012 includes long PCR amplification of the unidentified gene from a *B. malayi* cDNA library, acquisition of *C. elegans pdf-1* mutant strains, and design of a transgenic construct using the promoter and regulatory regions of *C. elegans* ligated to the coding regions of the proposed *B. malayi* gene.

The work conducted during summer 2012 consisted of building the three-part *C. elegans – B. malayi* construct and design of methods to perform a crawling locomotion analysis on *C. elegans pdf-1* mutant strains. For the construct design, vector cloning and sequencing of the ligation for pieces “A” and “B” of the construct were tested. However, results indicated that the ligation, done during the 2011-12 academic year, was not successful. Thus the construct focus shifted towards confirming that piece “B”, a hybrid of the *B. malayi* coding region and *C. elegans* intron regions, was successfully made.

As for the locomotion analysis, it was decided that the Parallel WormTracker™ module for MATLAB® would be used to analyze the crawling locomotion of *C. elegans* mutant and wild-type strains. This module, available via the Department of Molecular and Cellular Physiology at Stanford University, identifies when the worms perform a change in direction (dubbed a “pirouette”), as well as their individual and collective speeds. Troubleshooting was performed on what video source would best integrate with the Parallel WormTracker™ module. Attempts were made with video footage captured in “DP controller”; a program written to integrate with an Olympus XDP71 microscope camera. However, the footage and analytical software did not integrate well and the analysis was spotty at best. (Supported by the Howard Hughes Medical Institute and the Blakeslee Fund in the Biological Sciences)

Advisor: Steven A. Williams

References:

¹World Health Organization. *WHO Lymphatic Filariasis Fact Sheet*. World Health Organization, Mar. 2011. Web. 19 Aug, 2012

²USA. Center for Disease Control and Prevention. *Parasites – Lymphatic Filariasis*. Global Health – *Division of Parasitic Diseases and Malaria*.

Tree Hazard Ratings at the Smith College Arboretum

Jennifer Rioux

The campus of Smith College is made beautiful by trees of all sizes. The same trees that beautify our campus can become significant hazards when in declining health. It was recommended by a lawyer that the botanic garden set up a system to ensure every tree on campus be thoroughly inspected on a regular basis to protect against accidents such as a limb falling on a pedestrian or a car. Systems for inspection have been created in the past but none fully met the needs of the botanic garden. The new rating system used was based off of tree hazard-rating methods from other arboretums and past botanic garden intern work. It was determined that rating trees using the USDA community tree risk evaluation form would be most useful to the staff of the botanic garden. This system rates the trees on a three to twelve point scale through four sections. The sections are probability of failure, size of defective parts, probability of target, and other risk factors. The ratings of these sections add up to a total score indicating the level of danger the tree poses. Thirty trees were rated to test the system this summer. The trees chosen for the sample were some of the least healthy trees on campus. Their ratings ranged from five to twelve. The tree with the terrifying rating of twelve will be removed in the near future. It is completely hollow from decay. Once rated the trees were mapped using GIS software and can be easily viewed on a campus map. This map allows the botanic garden staff to visually see which trees need attention and when they need it most. This project is ongoing and will become even more useful as trees are added to the map. (Supported by the Schultz Foundation)

Advisor: Michael Marcotrigiano

References:

- Albers, J. S., Pokorny, J. D., & Johnson, G. (2003). Defective trees: Risk assessment guidelines. *Urban tree risk management*, 10(8), 1-9.
- Davison, E., & Brandt, B. (2009). Campus tree care plan. *University of Arizona Campus Arboretum*.
- Jonnes, J. (2011). What is a tree worth? *The Wilson Quarterly*.

Updating and Curating the Smith College Herbarium

Mikaela Sanders

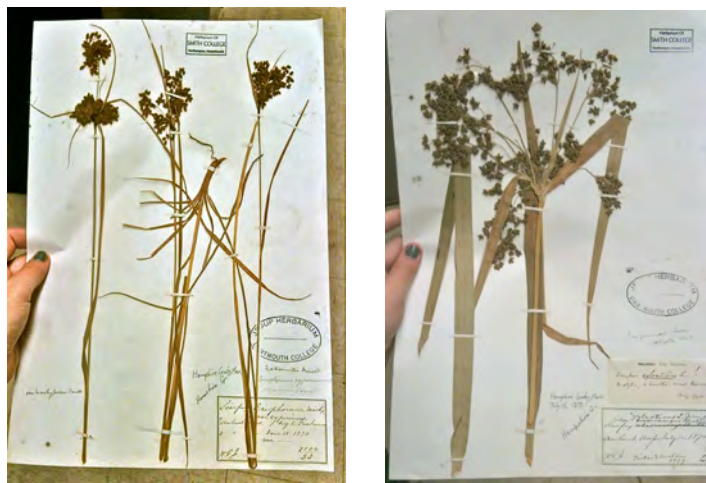

The Smith College herbarium is home to nearly 60,000 pressed plant specimens. These collections include plant material from the mid-19th century through recent decades, representing specimens from around western Massachusetts, New England, and regions as far as the Philippines and Eastern Europe. Before this summer, Smith's herbarium specimens were stored in a comparatively inaccessible attic room on the fourth floor of Burton Hall. This windowless, dusty, and cluttered space was not conducive to student use, and had no space for classroom or research purposes. This summer, I assisted Jesse Bellemare with the large task of transferring the herbarium files from their previous home to a new location in Sabin Reed 250-251. This new herbarium offers a well-lit, spacious place for students to comfortably access and view Smith's extensive collection of plant specimens. I designed a layout for the herbarium shelves in Sabin Reed 250-251, and I ultimately moved at least half of the collection into the new space.

In addition to moving herbarium files, I began reorganizing the specimens under a new filing system that highlights specimens from the Massachusetts and general New England area. Massachusetts specimens were sorted to the top of each species folder, followed by specimens from other New England states, followed by specimens from all other geographic regions. This new system will make the plant species that students are most likely to find in the wild easier to locate in the herbarium. I also updated the collection's taxonomy and nomenclature according to the latest scientific definitions. I separated basal angiosperms from dicots, organizing them in their own distinct area. Ferns and lycopodiums, gymnosperms, monocots, basal angiosperms, and dicots were all transferred separately and in alphabetical order by scientific name.

A highlight of this project was the herbarium-related fieldwork I did with Jesse Bellemare. We visited MacLeish Field Station twice and collected as many species of ferns and lycophytes as we could find, with the goal of creating a new "Flora of MacLeish" section of the herbarium. I collected over twenty different plant species, recorded their habitats and scientific names, and preserved and pressed them on herbarium paper. Future plant biology classes will have the opportunity to add to these MacLeish specimens, with the ultimate goal of documenting every plant species present at the field station.

Once all the herbarium specimens are transferred to their new location, Smith's biology and environmental science students will be able to study the structures and different life stages of local and global flora by viewing them in real life. The herbarium will greatly improve student understanding of plant taxonomy and organization. This summer's herbarium project began the process of bringing this invaluable collection of specimens into a much more active academic and research area of the Science Center, which will greatly increase herbarium accessibility and use. (Supported by the B. Elizabeth Horner Fund in the Biological Sciences)

Advisor: Jesse Bellemare

Decoding the Promoter Region of the Thioredoxin Peroxidase-2 Gene in *Brugia malayi*

Iju Shakya, Louise Hart Bodt and Krithika Venkataraman



Figure 1. Gel Electrophoresis Results from Qiagen Maxi-prep Kit.

Sample	Luminometer Reading (RLU)
PBS	0.023
Wild Type (without DNA)	0.065
E8	0.073
58	0.072
A8	0.067
B8	0.064

Table 1. Luminometer Readings from DNA Transfection in *Brugia pahangi*.

With over a billion people at risk of infection,¹ Lymphatic filariasis (LF) is considered a leading cause of disability. LF is a Neglected Tropical Disease caused by *Wuchereria bancrofti*, *Brugia malayi*, and *Brugia timori*. During the L3 stage, when these parasites transition host from mosquito to human, the parasite is considered most vulnerable. To manipulate this stage, the thioredoxin peroxidase-2 (*tpx-2*) gene was studied in our project. The thioredoxin peroxidases transcribed by this gene are crucial, as they defend *B. malayi* from toxic oxygen radicals released by the host immune cells. Our study was based on mutating the *tpx-2* promoter, which allows the gene to be turned on and off. Using a luciferase assay, the efficiency of the mutated promoters was measured, based on differences in fluorescence levels. This enables future identification of important regions of the *tpx-2* promoter for determining future vaccine targets. For the purpose of this project, *Brugia pahangi* was used as a safe, reliable model for investigation, as it does not infect humans, unlike *Brugia malayi*.

In order to transfect DNA into *Brugia pahangi*, the required DNA from transformed cells was streaked and inoculated. The DNA (wildtype E8 and mutants 58, A8, and B8) was then isolated using a Qiagen maxi-prep kit and run on a gel (Figure 1). The concentrations of the DNA were then measured with the Qubit.

Following this, approximately 1,000 *B. pahangi* were cultured using a calcium chloride precipitation technique. DNA was then added to eight wells of 100 worms each, leaving two wells of 100 worms without added DNA to serve as the control.

After ten days, the worms were lysed and measured with a luciferase assay in the luminometer (Table 1). The data were inconsistent with prior results, and inconclusive due to contamination and inconsistency with transfection.

The next step will be to repeat the experiment for more luminometer measurements. Additionally, an alternate assay technique will be implemented, exploiting the properties of green fluorescent protein, instead of luciferase. (Supported by the Blakeslee Fund in the Biological Sciences)

Advisor: Steven A. Williams

References:

¹CDC. (2010)/ Parasites - lymphatic filariasis. (2010). Retrieved from <http://www.cdc.gov/parasites/lymphaticfilariasis/index.html>.

Metagenomic Study of the Equine Gastrointestinal Tract before and after Treatment with the Anthelmintic Medication, Ivermectin

Rachael Sirois

Horses require constant anthelmintic treatment in order to prevent infection by a range of parasitic nematodes. Infection by parasitic nematodes can lead to a variety of symptoms, including retarded growth, weight loss, anorexia, anemia, recurrent colic, digestive disturbances, general weakness, and in severe cases, death. Many anthelmintic treatments work by interfering with the nervous system and muscle function of the parasite, but they may also eliminate other organisms, such as natural gut bacteria and fungi. The ideal way to study this process while better understanding the equine gastrointestinal tract is to conduct a metagenomic study of the gastrointestinal tract microbiome.¹ This study will be performed with the purpose of addressing two specific aims: 1) identify the approximate genetic composition of samples isolated from the equine gastrointestinal tract, thereby providing an accurate representation of the microbial community, and 2) track individual species throughout the duration of the treatment cycle using high-throughput sequencing.

The central hypothesis is that the presence of these parasitic nematodes, or the drugs used to treat them, may cause changes in the balance of the gastrointestinal tract microbiome and, in turn, adversely affect the health of the horse. DNA samples will be isolated from equine fecal samples throughout the duration of pre-treatment, treatment, and post-treatment with the anthelmintic medication, *Ivermectin*. After determination of sample genetic composition through use of the Automated Ribosomal Intergenic Spacer Analysis (ARISA) method,² genomic DNA samples will be sequenced using the high-throughput sequencing technology, Ion Torrent by Life Technologies, which is to be provided by New England Biolabs in Ipswich, MA. The proposed research is significant because it addresses the need for a better understanding of the equine GI tract microbiome, a valuable field that is highly underrepresented in the biology sphere.

Two fecal samples, Pre-treatment with Ivermectin and Post-treatment with Ivermectin, were appropriately prepped for sequencing on the Ion Torrent, which included end-repair of the samples and adapter ligation. The Ion Torrent generates relatively shorter reads, ranging from 170-200 base pairs and thus, bioinformatics will be an important component to this project. Sequencing of the pre-treatment samples generated 986 contigs comprised of 394,376 base pairs. The next stage for this project will be to decide on a data analysis program, such as Geneious or Galaxy, to analyze the data from both Pre-treatment and Post-treatment samples. This will be the aim for my research going into the 2012-13 academic year and will be the focus of my master's thesis to be presented at the end of the spring semester. (Supported by Blakeslee Fund in Biological Sciences)

Advisor: Steven Williams

References:

- ¹Santos, A. S., et al. "Understanding the Equine Cecum-Colon Ecosystem: Current Knowledge and Future Perspectives." *Animal* 1.1 (2010): 1-9. Print.
- ²Popa, R., et al. "Limitations and Benefits of ARISA Intra-Genomic Diversity Fingerprinting." *Journal of Microbiological Methods* 78.2 (2009): 111-8. Print.

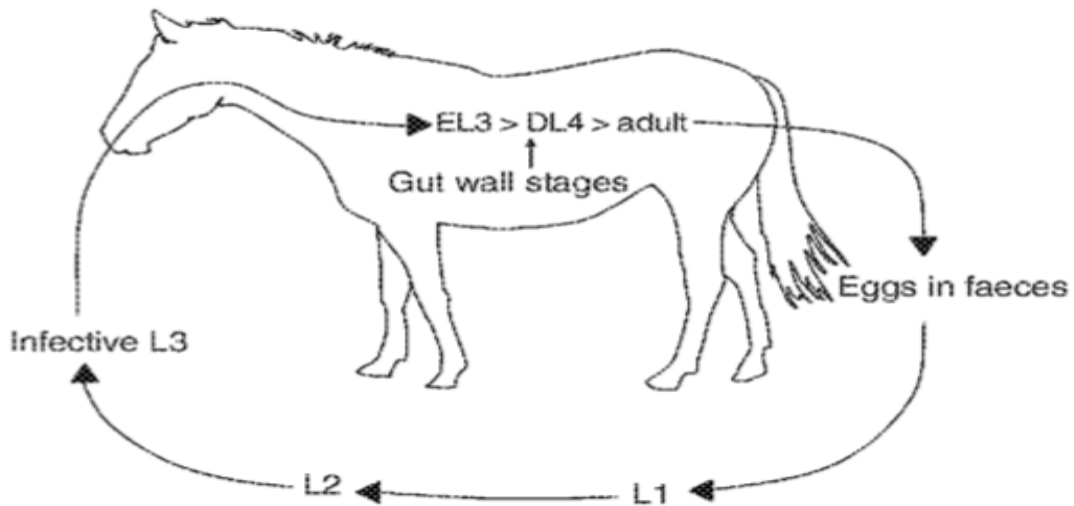

Fig 1: Life cycle of cyathostomins: L1: first stage larvae; L2: second stage larvae; L3: third stage larvae; EL3: early L3; DL: developing fourth stage larvae (comprising late L3 and developing L4).

Figure 1: Life cycle of small stonglyes in the horse.

Matthews, J. 2011. HBLB's advances in equine veterinary science and practice: facing the threat of equine parasitic disease. *Equine. Vet.* 43:126-132.

A PCR-Free Assay for the Detection of *Brugia Malayi* in Mosquitoes

Francesca Tomaino

Lymphatic filariasis is a tropical disease caused by the human parasites *Wuchereria bancrofti*, *Brugia malayi* and *B. timori*. These thread-like worms inhabit the human lymphatic system, causing both acute episodes of inflammation and chronic lymphoedema or elephantiasis.¹ The Global Program to Eliminate Lymphatic Filariasis is currently implementing a program of mass drug administration (MDA) to eliminate lymphatic filariasis globally; however, it is necessary to measure the changing infection rates of the disease over the course of MDA in order to evaluate the program's success and determine when MDA can be stopped.

Since the disease is transmitted by mosquito, one method of monitoring its prevalence is to collect mosquitoes and test them for the presence of parasites. Real-time PCR assays for the detection of *B. malayi* parasites in mosquitoes have been developed for this purpose.² These assays, while effective, require expensive equipment, including—most notably—a thermal cycler for the PCR reaction. Many of the countries in which lymphatic filariasis is endemic are extremely poor and lack laboratory facilities that are equipped to carry out diagnostic testing. Because of this, mosquitoes collected in endemic countries must often be shipped out of country for processing, an expensive arrangement that not only compromises the efficiency of elimination efforts, also puts developing nations in a position to be taken advantage of, since they are forced to give up legal rights to samples. An assay that does not rely on PCR for parasite detection would eliminate the need to ship samples and would encourage the development of laboratory facilities within the developing countries where this disease is problematic. I have developed a PCR-free assay for the detection of filarial parasites in mosquitoes that has the potential to do just this.

Following extraction of DNA from pooled mosquitoes, parasite DNA was amplified using helicase-dependent amplification (HDA), a novel type of DNA amplification reaction which uses a helicase enzyme to separate the strands of the template DNA, eliminating the need for thermal cycling with a PCR machine. Amplification was achieved using HDA kits (IsoAmp[®] III) obtained from BioHelix and specific primer sets designed to amplify a 97 base pair fragment of the Hha I repeat in *B. malayi*. The reaction, which takes place during a 90-minute incubation at 65° C, was optimized to assure the highest efficiency possible.

Milenia[®] HybriDetect strips from Milenia Biotec were used to detect the product, which was labeled with both FAM and biotin using a probe and labeled primer. Following hybridization of the probe to the amplified product, the test strips are placed in the samples and allowed to incubate at room temperature for fifteen minutes. The appearance of a positive purple band on the strip in addition to a control band indicates a positive result. The test strips were shown to be as sensitive as gel electrophoresis in their ability to detect amplified DNA.

The assay was determined to be sensitive enough to detect one infected mosquito in a pool of twenty total mosquitoes. However, in addition to the human parasite *B. malayi*, the assay was also shown to detect the closely related animal parasite *B. pahangi*. Therefore, in regions where these two parasites are co-endemic, follow-up testing of positive samples will be required. Finally, a blind study was carried out to confirm that the HDA assay yields identical results to the standard qPCR assay that is currently in use. This PCR-free assay can be used to reliably detect parasitic DNA in pooled mosquito samples without the need for expensive equipment. With this assay, labs in countries where lymphatic filariasis is endemic would have the capacity to process their own mosquito samples instead of shipping them to labs in other countries. (Supported by the Nancy Kay Holmes Fund)

Advisor: Steven Williams

References:

¹"Lymphatic Filariasis." World Health Organization. www.who.int/mediacentre/factsheets/fs102/en/.

²Rao, R. U., G. J. Weil, K. Fischer, T. Supali, and P. Fischer. 2006. Detection of *Brugia* parasite DNA in human blood samples by real-time PCR. *Journal of Clinical Microbiology* 44: 3887–3893.

Methodology for the Isolation and Detection of Sesquiterpene Lactones in *Neurolaena Lobata*

Kristine Trotta

Sesquiterpene lactones (SLs) are a class of terpene-derived organic compounds that are characterized by their polycyclic C₁₅ structure and five-membered lactone ring. They occur in abundance in plants of the family Asteraceae, and have been shown to be bioactive components in some traditional plant medicines that treat inflammation and intestinal worms, among myriad other conditions.¹ Evidence for the effectiveness of *Neurolaena lobata* in weakening and killing *Brugia pabangi* nematodes² (related to the *Brugia malayi* nematodes that cause lymphatic filariasis) indicate that SLs may be at least partially responsible for the plant's bioactivity. Identification of the SLs is necessary for attempting to elucidate the molecular mechanism of *N. lobata*'s lethality against *B. pabangi*.

An extraction of 5 g dried, crushed *N. lobata* (The Arvigo Institute, LLC) was prepared with 50% aqueous methanol twice by reflux at 50°C for 30 minutes³ to yield 100 mL of a transparent brown liquid. The extract was washed with 300 mL ethyl acetate,³ and the bright yellow organic layer was separated and left to evaporate. This yielded a yellow residue that was reconstituted in dichloromethane, gravity filtered³, divided into aliquots, and vacuum centrifuged to evaporate the solvent. Aliquots were reconstituted and consolidated in a total of 20 mL 50% aqueous methanol. 7 g aluminum oxide was added³. Filtration yielded approximately 15 mL of a transparent yellow liquid. Compound separation and detection was performed by preparative thin layer chromatography using silica gel GF as the stationary phase and toluene/ethyl acetate (3:2) as the mobile phase.⁴

Preparative TLC yielded five distinct spots per lane (Figure 1) with the following mean R_f values: (1) 0.27, (2) 0.42, (3) 0.52, (4) 0.62, (5) 0.69. This suggests that there may be at least five detectable varieties of SLs in *N. lobata*. Spots 1, 2, and 3 are consistent with previous findings: 0.29 (Neurolenin D), 0.42 (Neurolenin C), and 0.53/0.54 (Neurolenins B and/or F), respectively⁴ (Figure 2). Spots 4 and 5 may be impurities or less polar SLs that may have not been previously described.

Sesquiterpene lactones may have an important role in *Neurolaena lobata*'s ability to kill *B. pabangi* nematodes. This preliminary work in detecting SLs in *N. lobata* is an essential step in the way of discovering the molecular mechanism for this plant's bioactivity. Future studies of this plant will involve large-scale extractions to attempt to purify SLs for structural analysis by NMR and IR, as well as applications of individual SLs in *B. pabangi* cultures to assess the efficacy of each isolated compound on worm mortality. (Supported by Howard Hughes Medical Institute)

Advisor: Steven Williams

References:

- ¹Chaturvedi, D. Sesquiterpene lactones: Structural diversity and their biological activities. In *Opportunity, Challenge and Scope of Natural Products in Medicinal Chemistry* [Online]. Tiwari V.K. and Mishra B.B., Ed; Research Signpost: Kerala India, 2011; Chapter 10, pp 313-334. http://www.trnres.com/ebook/uploads/tiwari/T_1302158793Tiwari-10.pdf (accessed 10 June 2012).
- ²Fujimaki, Y., et al. Macrofilaricidal and microfilaricidal effects of *Neurolaena lobata*, a Guatemalan medicinal plant, on *Brugia pabangi*. *Journal of Helminthology* [Online] **2005**. 79, 23-28. <http://journals.cambridge.org/action/displayAbstract?fromPage=online&aid=712552> (accessed 1 June 2012)
- ³Passreiter, C.M. Quantification of Sesquiterpene Lactones in Leaves of *Neurolaena lobata*. *Phytochemical Analysis* [Online] **1998**. 9, 67-70. [http://onlinelibrary.wiley.com/doi/10.1002/\(SICI\)1099-1565\(199803/04\)9:2%3C67::AID-PCA389%3E3.0.CO;2-V/abstract](http://onlinelibrary.wiley.com/doi/10.1002/(SICI)1099-1565(199803/04)9:2%3C67::AID-PCA389%3E3.0.CO;2-V/abstract) (accessed 1 June 2012).
- ⁴Passreiter, C.M., Wendisch D, Gondol D. Sesquiterpene Lactones from *Neurolaena lobata*. *Phytochemistry* [Online] **1995**. 39, 133-137. <http://www.sciencedirect.com/science/article/pii/0031942294008630> (accessed 13 June 2012).



Figure 1: Compound separation of the methanol extract of *N. lobata* under UV detection (254 nm). All replicates of this material under the given conditions yielded five distinct spots.

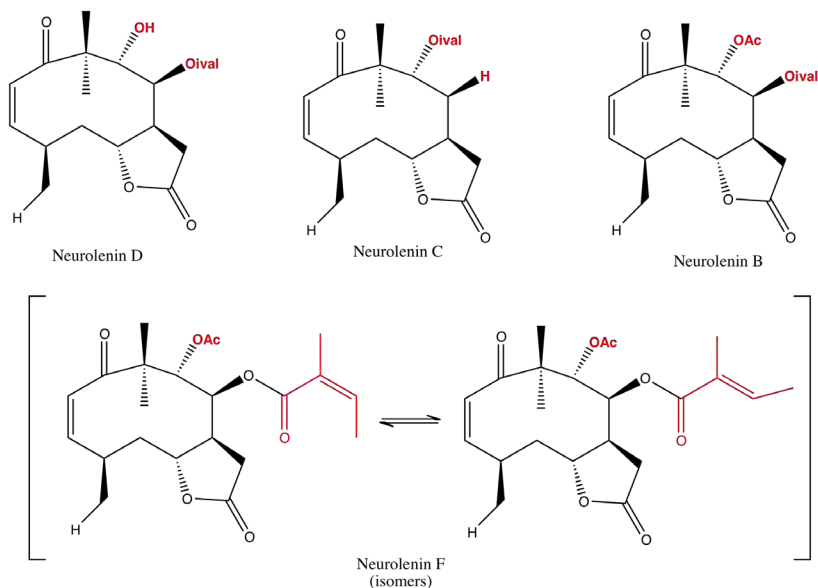

Figure 2: Proposed sesquiterpene lactones detected by preparative TLC in accordance with Passreiter, Wendisch, and Gondol (1995).⁴ Though all compounds have the same carbon backbone, they vary by functional groups, as displayed in red. Note that 'ival' is an abbreviation for 'isovaleric acid', a five-carbon acidic functional group, and that 'OAc' is an abbreviation for 'acetoxy group', an oxygen-modified acetyl group.

A Phylogeographic Comparison of the Invasive Green Crab *Carcinus maenas* in Relation to Claw Strength and Cuticle Thickness

Sarah Tucker

In the last 100 years, the introduced European green crab has made a northern expansion into colder waters of the Gulf of Maine. Cold water temperature limits the deposition and sequestration of calcium carbonate in the shells of many marine organisms.¹ Whether water temperature similarly affects the thickness and strength of crustacean cuticles, however, is not proven. Preliminary studies conducted in the summer of 2010, through the Smith SURF program, have suggested that green crab populations in colder waters have thinner exoskeletons and thus may be more prone to claw breakage. Due to the potential impacts of temperature on the crab's ability to forage and ultimately survive, severe genetic selection is also likely.

This summer we collected specimens from northern and southern green crab populations in the Gulf of Maine to sample phylogeographic diversity and measure cuticle strength and thickness. Specimens were brought back to the laboratory and coaxed to reflexively drop their crushing claw. The claw was then secured into an apparatus that provided consistent tensile force until breakage occurred. Photographs of the cross-sectioned claws were taken for analysis of cuticle thickness. These ecomorphological measurements have largely improved the sample size of the data set collected during the summer of 2010.

An additional layer of this study has been the investigation of techniques to assess the phylogeography of our sampled populations. Specifically, I have investigated primers and techniques for mitochondrial DNA sequencing. This work will test for a correlation between the breakage resistance and cuticle thickness and genetic diversity of northern and southern green crab populations in the Gulf of Maine.

Traditionally the European green crab movement northward was hypothesized to be limited by the colder waters of the Canadian Maritimes. In the past ten years however, recent research has shown established populations in the Maritimes.² This research is encouraging of a potential genetic basis for the hypothesized spatial differences in resistance to breakage and cuticle thickness. Further analysis of ecomorphological measurements and assessment of phylogeography will be continued as an honors thesis project in the 2012-13 academic year. (Supported by Elizabeth B. Horner Fund in the Biological Sciences)

Advisor: L. David Smith and Laura Katz

References:

¹ Baldrige, A. K. and L. D. Smith. 2008. "Temperature constraints on phenotypic plasticity explain biogeographic patterns in predator trophic morphology." *Marine Ecology Progress Series* 365: 25-34.

² Roman, J. 2006. Diluting the founder effect: cryptic invasions expand a marine invader's range. *Proceedings of the Royal Society of Biological Studies*, Vol 27 1600: 2453-2459.



Cellular and Molecular Characterization of Post-optic Commissure Formation in the Zebrafish Forebrain

Carla M. Vélez and Tatenda D. Mahlanza

During brain development, the process by which axons cross the midline is essential for the proper connection and communication between the two sides of the central nervous system. These connections, known as commissures, are formed by attractant and repellent cues that guide axons to their specific targets. Three of these commissures exist in the vertebrate forebrain; the optic nerve, the anterior commissure and the post-optic commissure. The focus of this research is determining the role of the Zebrafish radial fiber (Zrf) 1-4 antibodies in the formation of the post-optic commissure. Current knowledge demonstrates that Zrf 1 binds to Glial fibrillary acidic protein (Gfap)¹, however, the target proteins for Zrf 2-4 are currently unknown.

Microscopic imaging is an essential tool in assessing the possible roles of Zrf antibodies during commissure formation. The creation of several transgenic fish lines facilitates the visualization of these processes. These lines were created by injecting DNA constructs directly into a wild-type embryo's cell while it's still in the one cell stage. Zebrafish embryos have the capacity to express this mutant DNA and proceed with normal development. The expression of these constructs is confirmed using fluorescent microscopy and the fish are currently in the process of reaching maturity so that the lines can be established by identifying founder pairs.

The creation and maintenance of these transgenic fish lines is imperative in the progression of this project's next phase; direct live-cell imaging of early brain development using Laser Scanning Confocal Microscopy. The visualization of this process will be a great learning tool in understanding the behavior of axons during early brain development. (Supported by the Howard Hughes Medical Institute).

Advisor: Michael J. Barresi

References:

¹Marcus, R.C. and Easter, S.S. (1995). Expression of glial fibrillary acidic protein and its relation to tract formation in embryonic zebrafish (*Danio rerio*). *The Journal of Comparative Neurology* **359**, 365-81.

Medicinal Plants: Hoax or Potential Breakthrough in Drug Development for Lymphatic Filariasis?

Jessica Wignall

Lymphatic Filariasis (LF), a debilitating tropical disease transmitted by mosquitos, affects 120 million people in 72 countries and has permanently disfigured about 40 million in the process.¹ The filarial nematodes (*Brugia malayi*, *Brugia timori*, and *Wuchereria bancrofti*) infect the human lymphatic system, causing inflammation and swelling of extremities. The strategy to eliminate the disease is in pandemonium, as new drugs have not been developed for more than 40 years.² The current drugs on the market have been reported to cause side effects, such as gastrointestinal disturbance, malaise, and skin rash.² The troubling side effects of synthetic drugs aside, all current drugs fail to target the infant stage of the parasite. Inflammation primarily occurs when the parasite molts into an adult.⁵ If drug manufactures could develop a drug that would target and kill the third larval stage of the parasite (L3), then they would significantly reduce the number of LF cases in at-risk populations. Even more advantageous would be a drug that could target both the L3 and adults nematodes, as those infected with this disfiguring disease should not be left untreated. In order for the scientific community to fight LF on both fronts, examination of the medicinal use of plant compounds to kill filarial worms is appropriate.

Bioactive plants, such as *Neurolaena lobata* are used medicinally in Central and South America.³ While few studies have used extracts of *N. lobata* on *Brugia pabangi* adults⁴ – which are closely related to *Brugia malayi* – the effects of *N. lobata* extracts at various concentrations in a time-dependent manner on *Brugia pabangi* L3s have not been documented. Additionally, since preliminary toxicity screenings indicate that *N. lobata* is not toxic to humans⁵ research must continue to explore *N. lobata* as a potential drug candidate for LF.

N. lobata extracts were prepared by crushing dried leaves in 10% ethanol and filtering the mixture by gravity filtration until the final volume reached about 15 ml. The solution was dispensed into 1.5 ml centrifuge tubes in aliquots of 1 ml and the tubes were lyophilized for six hours at a “low drying rate” with HEAT “off.” A brown tar-like substance remained at the bottom of each tube. All tubes were weighed, resuspended in MEM medium, and vortexed to assure the solution was completely homogenous. *Brugia pabangi* L3s were obtained from the Filarial Research Reagent Repository and a modified version of the *Brugia pabangi* culture protocol developed by T.V. Ragan and co-authors at the UConn Health Center was followed.⁶ A “cocktail” of the following antibiotics were added to a 500 ml bottle of Minimum Essential Medium (MEM): gentamicin, 0.3% ciprofloxacin, and 5000U penicillin streptomycin. The antibiotics fungizone, 5000U pen strep, gentamicin, and 0.3% base ciprofloxacin were added to a 500 ml bottle of RPMI. On the day of the culture, the complete culture medium was made, which required combining 90 ml of the MEM with antibiotics, 10 ml of fetal bovine serum, and 20 µl of ceftazidime into a 120 ml glass bottle. Four washes were carried out using the RPMI medium with antibiotics and the L3s were transferred into each wash solution with a P-200. This procedure was repeated twice until all 1200 L3s were successfully plated into two 6-well plates containing 5 ml of complete culture medium in each well. The 6-well plates were incubated in a 37°C, 5% CO₂ incubator. The death toll was counted after 24 hours of incubation and then the worms were left alone until day five. On day five, 50 µl of 100x vitamin C was added to each well (experimental and positive controls) to optimize molting and *N. lobata* extract was administered to designated wells. Triplicates of the following concentrations of extract were added: 200 ppm, 300 ppm, and 400 ppm. After 24, 48, and 72 hours of exposure to the plant extract the number of dead/alive L3s, molts, and partial molts were counted for calculation.

Five cultures of 1200 L3s with uniform culture conditions yielded promising results for the utilization of *N. lobata* against *Brugia pabangi* and alike parasites. By varying the concentration of *N. lobata*, I was looking to observe how mortality and molting were changing with respect to time. Findings indicate that this plant speeds up the molting process (Figure 2) and causes premature death of the L3s at all extract concentrations (Figure 1, 3, 4). By 72 hours, nearly 100% mortality was observed for all experimental concentrations. Kristine Trotta and I will continue our research through the 2012-13 academic year as Special Studies to examine how this plant is working at the molecular level, regarding the exact compounds involved in killing the L3s *in vivo*, along with further toxicity screenings, and cultures using *Brugia pabangi* adults. (Supported by Howard Hughes Medical Institute)

Advisor: Steven Williams

References:

- ¹“Lymphatic Filariasis.” *WHO*. Jan. 2012. Web. 20 Feb. 2012. <<http://www.who.int/mediacentre/factsheets/fs102/en/>>.
- ²Zaridah, M.Z., S.Z. Idid, A. Wan Omar, and S. Khozirah. “*In Vitro* Antifilarial Effects of Three Plant Species against Adult Worms of Subperiodic *Brugia Malayi*.” *Journal of Ethnopharmacology* 78.1 (2001): 79-84. 27 Sept. 2011. Web. 20 Feb. 2012. <<http://www.sciencedirect.com/science/article/pii/S0378874101002860>>.
- ³Caceres, A. (1998). Plants used in Guatemala for the treatment of protozoal infections. I. Screening of activity to bacteria, fungi and American trypanosomes of 13 native plants. *Journal of Ethnopharmacology*, 62(3), 195-202.
- ⁴Fujimaki, Y. (2005). Macrofilaricidal and microfilaricidal effects of *Neurolaena lobata*, a Guatemalan medicinal plant, on *Brugia pahangi*. *Journal of Helminthology*, 79(1).
- ⁵Huq, Saira (2012). Honor Thesis with Steven Williams, 1-68.
- ⁶Rajan, T.V., Natalia Paciorkowski, and Carol McGuiness. “Ascorbic Acid Is a Requirement for the Morphogenesis of the Human Filarial Parasite *Brugia Malayi*.” *The Journal of Parasitology*, 89.4 (2003): 868-70. The American Society of Parasitologists. Web. 21 Aug. 2012. <<http://www.jstor.org/stable/3285895>>.

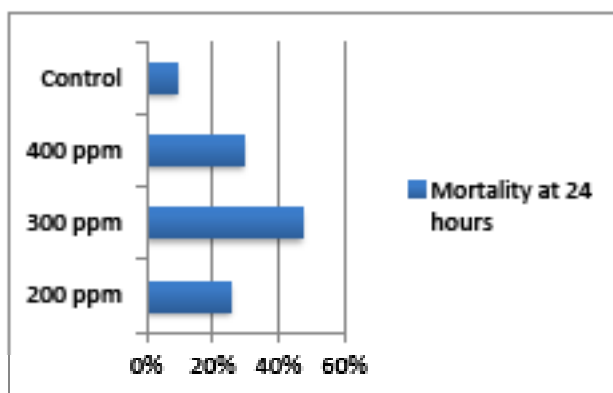

Figure 1: Mortality of *Brugia pahangi* L3s after 24 hours of exposure to *N. lobata*. Untreated (i.g. media and vitamin C only) L3s were the positive control group and all other L3s were treated with varying concentrations of *N. lobata* extract. The average mortality was calculated from triplicate wells each containing 100 L3s over the course of five cultures. The optimal concentration appears to be 300 ppm, as it killed nearly 50% of the L3s after a 24-hour period.

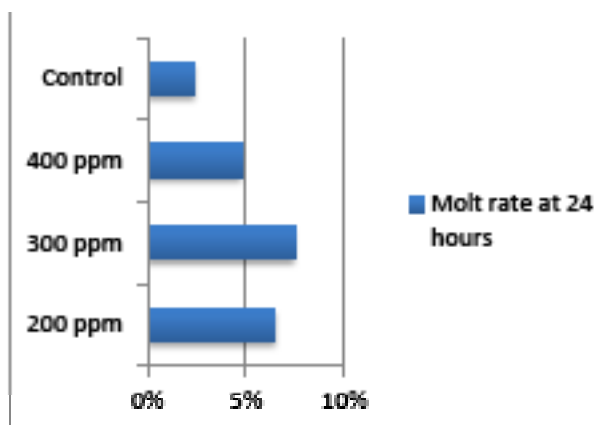

Figure 2: L3/L4 molt rate of *Brugia pahangi* L3s after 24 hours of exposure to *N. lobata*. L3s molting is unsynchronized and significant molting (i.g roughly 80%) is not observed until later in the life cycle (day 10 and day 11). Therefore, *N. lobata* is inducing molting in the treated wells.

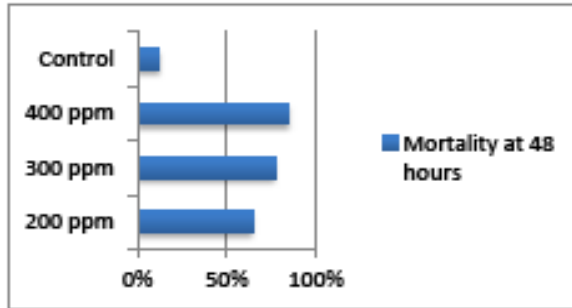

Figure 3: Mortality of *Brugia pahangi* L3s after 48 hours of exposure to *N. lobata*. Continued exposure to *N. lobata* leads to statistically significant L3 death.

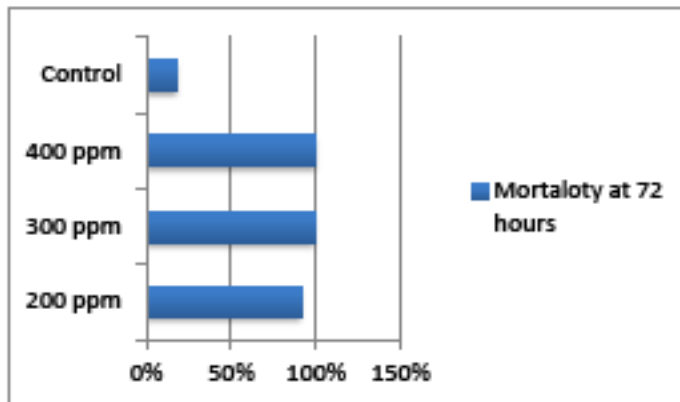

Figure 4: Mortality of *Brugia pahangi* L3s after 72 hours of exposure to *N. lobata*. All concentrations of *N. lobata* have about the same potency in killing nearly 100% of the L3s by the 72-hour mark.

Testate Amoebae and Discovering that Environment May Have an Effect on the Population of a Species

Cameah Wood

Testate amoebae are single celled microorganisms that dwell within bogs, near or in freshwater, soils, and some vegetation. These organisms are enclosed within shells that differ in shapes and sizes. In addition, they move and eat by using pseudopodia. (Pseudopodia are very important when identifying whether the amoebae being viewed under a microscope is alive.) Noticing the different physical characteristics of the testate amoebae is another very important characteristic when viewing testate amoebae. This helps to identify the species, until they are identified by their genetic make-up. Testate amoebae are important to science because they have the capabilities of helping scientists research and discover the climate conditions and changes within an area or habitat that can span over thousands of years. Over the period of time which I conducted research, I collected viewed, identified and classified testate amoebae from local bogs. This helped to spark ideas for future projects.

When conducting research with testate amoebae, collecting is the beginning. Traveling to different local bogs such as Acadia, Harvard Forest, and Bear Swamp etc., has helped us to maximize the possibility of collecting an array of different species of testate amoeba. At the collection sites, we then look around for sphagnum moss. This type of vegetation, is where majority of testate amoebae dwell, this is due to the ph. levels existent within the moss. Testate amoebae thrive off of acidic vegetation such as the sphagnum moss. In addition to this, we also collect a sample of the water from the area which the sphagnum is located. From there we view our samples, make note of the number of species we find, mouth pipette them, genome amplify them, clone sequence, and then proceed to analyze our results.

After repeatedly doing this, many things were realized that there was a pattern within the species population within different sites. Within some sites for example, the testate amoebae *Hyalosphinia Papillio* may be more existent then in other places. After coming to that conclusion, the characteristics of the sites where identified. This identification can consist of whether or not location of a sample was higher up on a hill, dryer (where there was little to no water available to sample) etc. After looking at all the different characteristics there is a possibility that different conditions of the environment have effect on the population of a species within a site, and further research can be conduction on this topic. (Supported by Blakeslee Fund in the Biological Sciences)

Advisor: Laura Katz

References:

- ¹*Microscopy-UK Micscape Microscopy and Microscopes Magazine*. Microscopy-UK Micscape Microscopy and Microscopes Magazine. N.p., n.d. Web. 20 Aug. 2012. <<http://www.microscopy-uk.org.uk/mag/indexmag.html>?<http://www.microscopy-uk.org.uk/mag/artjun03/gsamoebae.html>>.

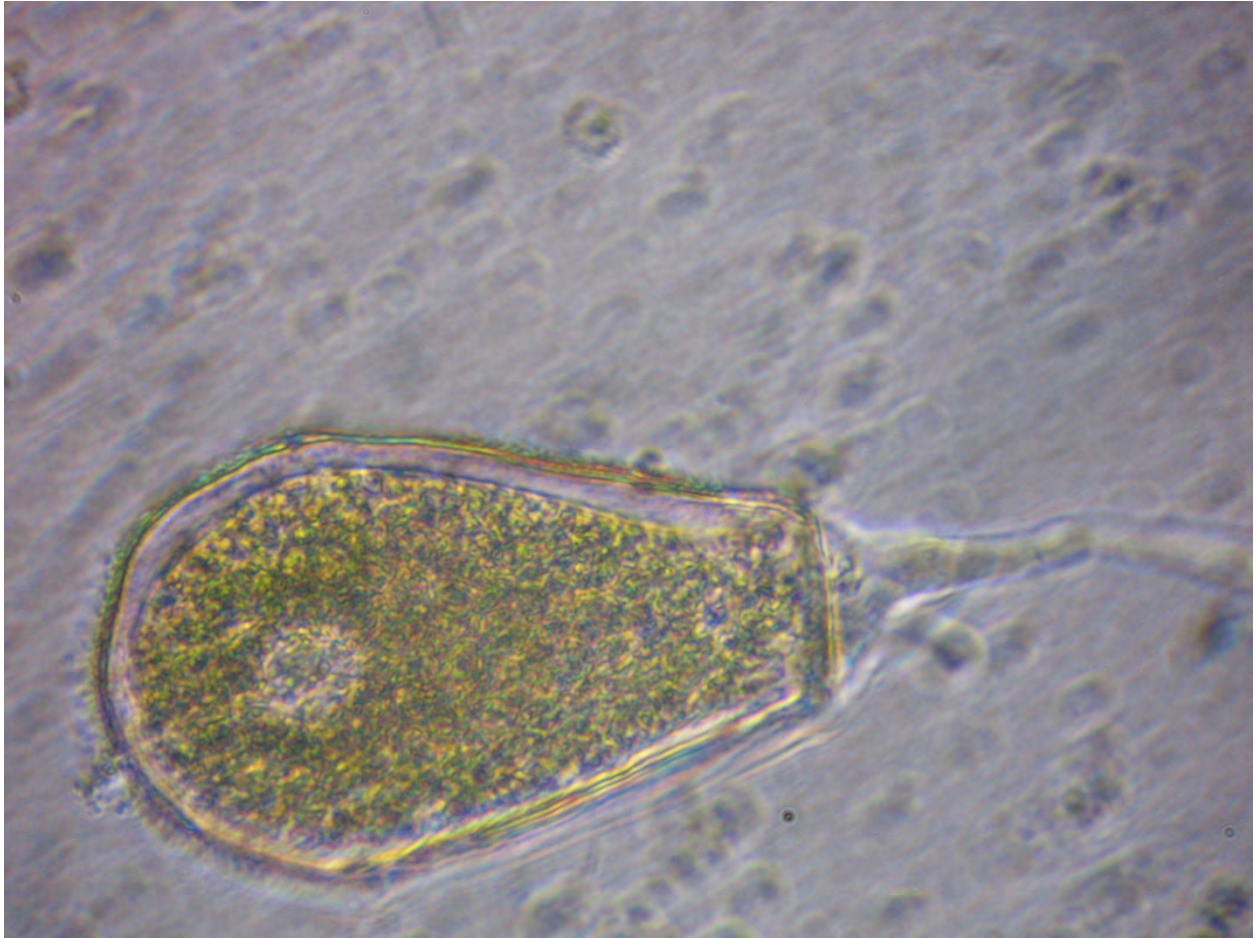

Identification of Specific Zrf (2-4) Antibody Protein Targets in the Developing Zebrafish Brain

Paula Zaman

In the developing Zebrafish brain, axons are typically guided across the midline by attractant and repellent protein cues to form commissures. During the summer, I looked at the formation of the postoptic commissure of the diencephalon in the Zebrafish brain. During pathfinding of these attractant/repellent cues, the POC axons closely contact a population of glial fibrillary acidic proteins (Gfap) positive astroglia covering the midline which was labeled by Zrf1. There were also three other Zrf (2-4) antibodies that we were interested in due to previous studies that have stated that they played a role in POC formation by interacting with unknown proteins.

The purpose of this research was to determine, quantify, and further look into what these proteins are and how they play a role in commissural formation. In this experiment I used two main techniques to determine what proteins these Zrf antibodies bind to, they are: immunoprecipitation and co-localization. Immunoprecipitation is a technique that precipitates a protein antigen out of solution using an antibody that specifically binds to that particular protein. This process is used to isolate a particular protein from a sample containing many different proteins. We will also be looking at co-localization on an imager called 'Velocity' for specific cell populations labeled with the different Zrf antibody labeling. Co-localization allows us to view protein interaction between known and unknown proteins. In this experiment, we will use Velocity which is a highly detailed imager that could take 3-D images of antibody localization. With this research, we hope to better the current model of axonal signaling in the POC and learn more about the key players that make neurological pathfinding. (Supported by the Howard Hughes Medical Institute)

Advisor: Michael Barresi

The Stabilizing Effect of Metalloporphyrins on Myoglobin

Metasebia Aberra

.....

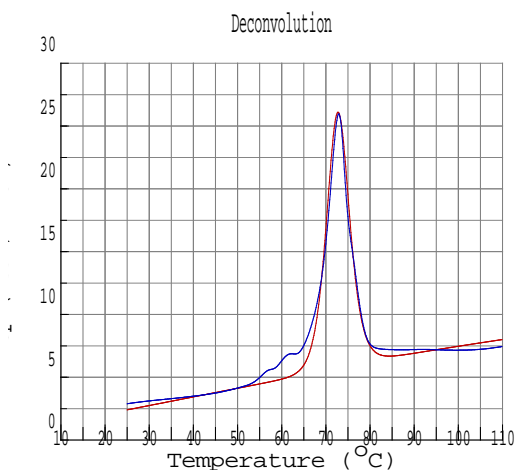

DSC of native myoglobin $T_m = 72.8^\circ\text{C}$,

$\Delta H = 139.0 \text{ kcal/mol}$, $\Delta C_p = 0.194$

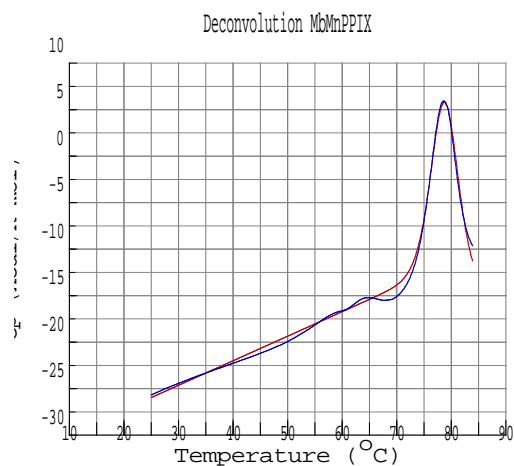

DSC of Mn-substituted myoglobin $T_m = 78.5^\circ\text{C}$,

$\Delta H = 123.5 \text{ kcal/mol}$, $\Delta C_p = 0.124$

Myoglobin is an oxygen binding protein found in the heart and skeletal muscles. It contains a metalloporphyrin prosthetic group called a heme that consists of a porphyrin ring with an embedded Fe II. Previous studies show that the presence of the heme group prevents the misfolding of myoglobin and the formation of other structures called amyloid fibrils. These structures are similar to the amyloid fibrils formed by other proteins during the course of Alzheimer's and Parkinson's disease.¹ My research focuses on identifying the specific features of the heme group that stabilize myoglobin, by substituting the heme group with different metalloporphyrins.

For my research I used a bovine heart as a source of protein. The myoglobin was purified from the heart muscle by several sequential steps, including centrifugation, salt precipitation, ultrafiltration, dialysis and ion-exchange chromatography. The purity of the myoglobin preparations were assessed by their UV-visible spectra and by gel electrophoresis. Finally, the myoglobin stability, thermal denaturation and amyloid formation were measured using differential scanning calorimetry (DSC). Based on the information obtained by DSC, the heat capacity (ΔC), free energy (ΔG), enthalpy (ΔH) and entropy (ΔS) of myoglobin denaturation were determined.

Using DSC, I measured the stability and thermal denaturation of native myoglobin (with heme as the prosthetic group) and made preliminary measurements of several metal-substituted porphyrins. Native myoglobin showed maximum unfolding at 72.8°C and an enthalpy of 139.0 kcal/mol . My future experiments include substitution of different transition metals (Co, Cu, Fe, Mn, Sn, Zn) as well as modified porphyrins such as deuteroporphyrin and mesoporphyrin.

I have presented this research to fellow SURF participants and faculty, and plan to continue this work. (Supported by the Howard Hughes Medical Institute)

Advisor: David Bickar

References:

¹ Friedrich, R.P, 2003, Mechanism of amyloid plaque formation suggests an intracellular basis of A β pathogenicity, PNAS early edition, 1-6.

Impact of Spiroiminodihydantoin Lesion on the Stability of an A 15-MER DNA Duplex

Yoon Bae

Oxidation of DNA bases is harmful, and it can cause diseases such as neurological disorders, carcinogenesis, and cancers. Guanine has the lowest reduction potential, and is easily oxidized to form 8-oxo-guanine (8-oxo-G), which is an unstable mutagenic DNA lesion. High valent metals such as Cr(V) and Ir(IV) readily oxidize 8-oxo-G further to form spiroiminodihydantoin (Sp) lesions.

In order to make the Sp lesion, DNA (5'-ACTGATTGTCGCACT-3') was reacted with sodium hexachloroiridate(IV) in sodium phosphate buffer (pH7) containing sodium chloride at 65°C for 30 minutes. The two diastereomers (Figure 1) of the Sp lesion were then purified and separated by High Performance Liquid Chromatography (HPLC). Finally, the thermodynamic stability of the Sp lesion was measured by differential scanning calorimetry, which measures the heat of chemical reactions or physical changes.

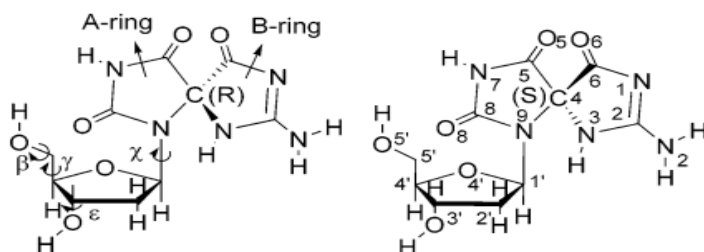

Figure 1. Two diastereomers of the Sp lesion.

Table 1. Thermodynamic data for the formation of the DNA duplex.

	Enthalpy(ΔH) (kcal/mol)	Entropy(ΔS) (kcal/kmol)	Melting Temp. (°C)	Free energy(ΔG) (kcal/mol)
5'-ACTGATTGTCGCACT-3' 3'-TGACTAACAGCGTGA-5'	-73±3	-0.22±0.01	64±1	-6±1
5'-ACTGATTGTCGCACT-3' 3'-TGACTAAAAGCGTGA-5'	-75±3	-0.24±0.02	53±1	-4±1
5'-ACTGATTSpTCGCACT-3' 3'-TGACTAA C AGCGTGA-5'	-77±2	-0.24±0.04	43±2	-1±1

In order to compare the thermodynamic stability of the Sp lesion, the control G-C and a G-A mismatched duplex of DNA were also tested (Table 1). The control duplex of DNA was found to be the most stable with the most negative value for free energy, indicating that the formation of the duplex is the most spontaneous and favorable. The high melting point also proves that the control duplex is the most stable. On the other hand, the duplex containing the Sp lesion is the least stable with the lowest melting point and the most positive value for free energy.

For the future research, different bases will be paired with the Sp lesion to find out how the base pairing of the Sp affects the thermodynamic stability of the Sp DNA lesion. (Supported by the National Institutes of Health)

Advisor: Elizabeth Jamieson

Factors that Affect the Inverted Umbrella Effect of $\text{Mn}(\text{CO})_5\text{X}$

April Birnie

.....

The inverted umbrella effect refers to the distortion of the equatorial carbonyls toward the X atom in manganese pentacarbonyl systems. The degree of distortion in the pentacarbonyl manganese systems depends on the nature of the sixth ligand. Previous research suggests that pi-orbital bonding is one of the causes of the inverted umbrella effect of the equatorial ligands.

During this research we used isonitriles (CNH) in the equatorial position, with various compounds in the two axial positions. As expected depending on the axial ligand the isonitriles distorted varying amounts. We started with keeping one of the axial ligands the same, starting with CO, and changing the other ligand: F, Cl, Br, CN, NC, and NH_2 . We also tried various combinations of these ligands together, including: F/Cl, F/Br, F/CN, F/ NH_2 . We found that not only did the equatorial ligands normally favor one of the axial ligands over the other, but, to our surprise, the hydrogen atoms on the isonitriles distorted even more drastically toward the favored ligand. (This drastic distortion made the systems look even more like inverted umbrellas.) For example in the F/Cl system the ligands curved towards the Cl giving a Cl-Mn-C angle of 82. If we define the ligand that the isonitrile bends away from as the “weak” ligand, F seemed to be the weakest, Cl and Br intermediate, and CN is the strongest.

As previously found for equatorial carbonyls, with NH_2 in one axial position, two of the equatorial ligands would drastically distort towards the NH_2 while the two (that were in the same plane of NH_2 hydrogen atoms) stay at about a 90-degree angle.

To investigate the possibility of hydrogen bonding we tried CNCH₃ as the equatorial ligand. All of the studied compounds acted the same way when a methyl group was substituted for the hydrogen, so we can rule out hydrogen bonding.

All of the calculations were made using Gaussian 09 using the B3LYP functional and a basis set of cc-pvDZ. (Supported by the Howard Hughes Medical Institute)

Advisor: Robert Linck

2D NMR NOESY of 11-mer Control DNA Duplex

Sophia Carroll and Danielle Chichester

Oxidative damage to DNA resulting from reactive oxygen species can cause mutations and contribute to cancer. The most common damage occurring from reactive oxygen species is the oxidation of guanine by hydroxyl radicals. The resulting 8-oxoguanine can with further oxidation form the carcinogenic Spiroiminodihydantoin (Sp) lesion, which gives rise to transversions of guanine to thymine in DNA replication. To inform the lesions' effects on B-DNA base-pairing and orientation, structural information of a B-DNA duplex exhibiting the Sp lesion can be gathered using 2D ¹H NOESY and COSY NMR spectroscopy.

In B-DNA, the magnetic interactions of certain aromatic and sugar protons through space and bonds form predictable 'walks' that allow these protons to be sequentially assigned, providing valuable structural information. The goal of the summer research was to gather this structural information about a control DNA duplex, one that did not exhibit the lesion, with 2D ¹H NOESY and COSY spectra. Cross-peaks of those protons that were nonexchangeable were assigned using COSY and NOESY spectra from a solution of 100% D₂O with W5 water suppression. Crosspeaks of exchangeable protons were also assigned from NMR spectra of a 90% D₂O/10% H₂O solution and W5 water suppression. Spectra from both solutions were gathered at 100 ms, 200 ms, and 300 ms mixing times and at room (25° Celsius) and cold (8° Celsius) temperatures.

In the D₂O NOESY spectra, we examined three different regions, based upon the protocol of the Berners-Price (2010) paper. The first region was the aromatic H1' region, and the peak assignments were made primarily from internucleotide and intranucleotide crosspeaks. These crosspeaks arose from sugar-nucleotide proton connectivities, and form the basis of the NOE walk. We compared the NOESY spectra collected at both temperatures, and found that the peaks were better resolved at the colder (8° Celsius) temperature. The second region examined was the aromatic thymine-methyl region, and we were able to unequivocally assign all observed peaks to the appropriate nucleotide in our 11-mer DNA duplex. The peaks in this particular region did not change when the spectra were collected at the colder temperature. The third region examined was the sugar H2'/H2'' region. These peaks arose from the proton-proton sugar connectivities, and were particularly difficult to assign because the peaks overlapped. We overlaid the collected COSY spectra onto the NOESY region to assist in assigning, but were unable to make unequivocal assignments. We were also unable to fully assign the H₂O/D₂O spectra due to time constraints.

Future plans for this project will be to confidently assign all peaks within the different regions of the D₂O NOESY spectra of the control DNA duplex. We will also examine the imino-amino region found in the H₂O/D₂O spectra. When the peak assignments for the control DNA duplex have been finalized, we will then move onto collecting similar NOESY spectra for the Sp lesion, using the same parameters fine tuned from working with the control. Considering the suspected structural differences of the Sp lesion, we expect to see these changes reflected in the disappearance/appearance of peaks in the different regions of the NOESY spectra. (Supported by the Howard Hughes Medical Institute)

Advisors: Elizabeth Jamieson and Cristina Suarez

References:

- Crenshaw, C. M.; J. E. Wade; et al (2011). Hidden in Plain Sight: Subtle Effects of the 8-oxoguanine Lesion on the Structure, Dynamics, and Thermodynamics of a 15-base Pair Oligodeoxynucleotide Duplex, *Biochemistry*. 50, 8463-8477.
- Ruhayel, R. A.; Berners-Price, S. J. (2010). Confirming the 3D Solution of a Short Double-stranded DNA Sequence Using NMR Spectroscopy, *J. Chem Ed.* 87, 7:732-734.

Cationic Diels-Alder Dienophiles Stabilized by Cobalt-Complexed Alkynes

Tessa Clark and Gloria Ortiz

The goal of this project is to continue research on the Diels-Alder reaction with Gassman-like cobalt-complexed cationic dienophiles. Last summer, Gloria Ortiz and Tessa Clark demonstrated that a cobalt-complexed ketal enhances the reactivity of the Diels-Alder reaction by promoting the formation of the carbocation dienophile (see Scheme 1), while an uncomplexed ketal does not. In order to prove that the cobalt-complexed alkyne alone could stabilize the cationic withdrawing group, non-Gassman type dienophiles were synthesized. Non-Gassman type dienophiles do not have an oxygen alpha to the cation in the dienophile.

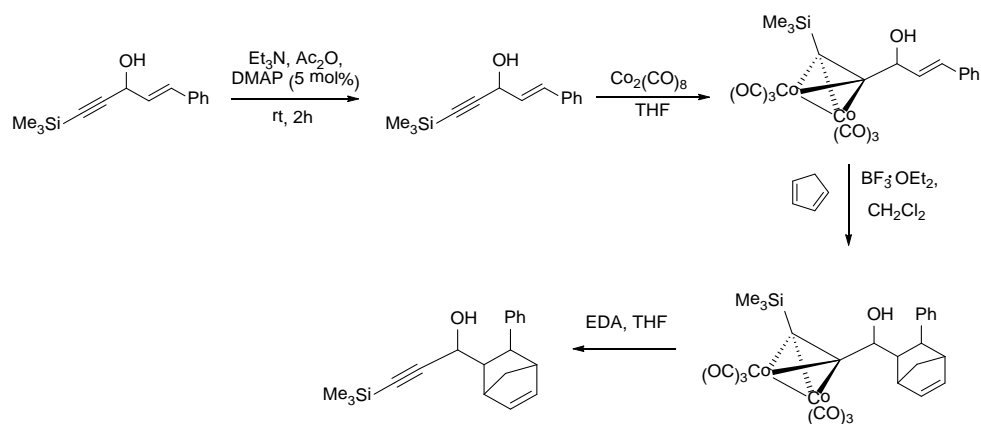

Scheme 1. Synthetic route of non-Gassman type dienophile

Two non-Gassman type dienophiles were synthesized, containing alcohol or acetate group, to test our hypothesis that the cobalt complexed alkyne will stabilize the cation intermediate and allow for a Diels-Alder reaction to occur. Using the two non-Gassman type dienophiles, we ran the Diels-Alder reaction with cyclopentadiene which Sarah found to be the most reactive diene. Under the reaction conditions, the alcohol and cyclopentadiene did not form the desired product. Decomposition occurred and an undetermined product formed.

Next year we plan to determine the regiochemistry and stereochemistry of the original cobalt-complexed ketal Diels-Alder product. To determine the stereochemistry of the Diels-Alder product, we hope to synthesize derivatives of the cycloadduct that will be crystalline, forming a crystal in order to run X-ray crystallographic analysis on the product. The reaction involves removing the ketal and reacting the ketone with tosyl hydrazine to form a crystalline tosyl hydrazine. We also plan to synthesize another non-Gassman dienophile ester and perform another Diels-Alder reaction. (Supported by the American Chemical Society Petroleum Research Fund)

Advisor: Kevin Shea

NMR Analysis of Ion Transport in Liposomes

Signe Dahlberg-Wright

The kinetic behavior of antibiotic gramicidin, naturally occurring helical monomers that dimerize to form ion channels, has been shown in literature precedents to be a second order reaction that is selective to monovalent alkali metal cations.¹ The ability to understand gramicidin's kinetic behavior in liposomes can be used for comparison in further research into the behavior of novel ionophores. Experimental variables in the formation of lipid vesicles in sodium chloride solution and the testing of gramicidin D—e.g. pH, lipid make-up, intra- and extracellular sodium ion concentrations, gramicidin concentration, incubation time, temperature, etc.—are all reaction conditions that can affect the ability of the gramicidin molecules to support ion flow, and therefore can affect the rate of this process.² These variables have been adjusted in order to optimize the incorporation of gramicidin channels into a lipid suspension, and using ²³Na-NMR to study sodium ion flux, has resulted in kinetic data (i.e. rate constant and reaction order) that support literature precedent. These results, in addition to ongoing work using other known ionophores with their own distinct kinetic data, will be used to determine the kinetic behavior of, and to propose a mechanism for, novel cyclopeptides that exhibit qualities that are similar to those found in known ionophores, namely structure, size, and ability to hydrogen bond. (Supported by the Howard Hughes Medical Institute)

Advisor: Cristina Suarez

References:

¹Buster, D.C.; Hinton, J.F.; Millett, F.S.; Shungu, D.C. *Biophys.* **1988**. *53*. 145-152.

²Riddell, F.G.; Hayer, M.K; *BB.A.* **1985**. *817*. 313-317.

Dopamine Cytotoxicity and its Implications Pertaining to Parkinson's Disease

Rosa Drummond

Parkinson's Disease is a neurodegenerative disease characterized by the loss of fine motor control, dementia, and the death of dopaminergic cells in the substantia nigra. This disease is very rarely genetic, but its overall cause is unknown as well as the cause of cell death. We investigated the role of dopamine itself in dopaminergic cell death. When dopamine (DA) is oxidized to DOPAC, a precursor to norepinephrine, a byproduct is hydrogen peroxide (H_2O_2), which in turn oxidizes DOPAC into cytotoxic hydroxyl radicals. Ultimately, these hydroxyl radicals may play an important role in, or be the cause of, cell death. We focused on the role of H_2O_2 and how best to measure the actual concentration of H_2O_2 in the affected cells (NIE-115 Neuroblastoma cell line). Our ultimate goal was to see how much dopamine, and in turn H_2O_2 , the cells could handle, and what concentration of dopamine was lethal to the cells.

We used chemiluminescence as an indicator of H_2O_2 levels. Luminol, when catalyzed by horseradish peroxidase (HRP), emits luminescence, which we measured with the SpectraMax M5/M5e Microplate Reader in the Center for Molecular Biology in Ford Hall. Using a 96-well plate, we silvered clear microwells via the Tollens' Reaction in order to decrease the luminescence absorbance observed in black wells and reduce the cross talk observed in white wells. We trialed a variety of concentrations of luminol and HRP in cell culture, as well as several different other chemicals relating to hydrogen peroxide, including catalase, aminotriazole, plasma amine oxidase, dopamine, and menadione. Our best results divulged a very smooth, concave up graph, indicating H_2O_2 levels began at relatively high levels and then decreased at an exponential-like level due to HRP. We also ran these tests over longer periods of time (i.e. one-two hours) and found similar results.

The SpectraMax gives levels of luminescence as Relative Luminescence Units (RLUs), and although we did not run enough trials to decisively say the exact concentration of H_2O_2 each RLU measured, our best estimate was 100RLU/nM H_2O_2 .

Perhaps one of our most important findings was that the neuroblastoma could easily survive long-term exposure (two days were tested) to luminol and HRP. If we had more time, our eventual experiment was to measure luminescence from brain slice preparations, using an entire DA pathway (the tuberoinfundibular pathway is the shortest DA pathway, and connects the arcuate nucleus of the hypothalamus to the median eminence and the pituitary gland). We would measure a baseline level of H_2O_2 by way of luminescence, and continue adding DA until the brain slice was no longer alive, theoretically meaning we reached our peak in healthy DA concentration and also the threshold of toxic DA concentration. We would hopefully also be able to gain some insight into DA production relating to circadian rhythms, by continuously monitoring the changes in dopamine release over extended intervals. (Supported by the Howard Hughes Medical Institute)

Advisor: David Bickar

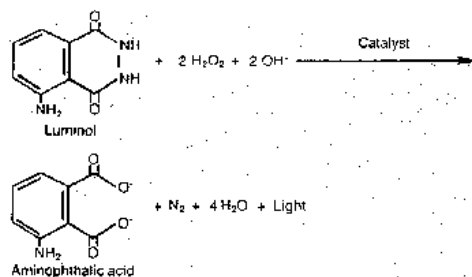

References:

<http://www.carolina.com/category/teacher%20resources/classroom%20activities/luminol%20the%20glowing%20reaction.do>

Development of a Tandem Diels-Alder/Pauson-Khand Reaction for the Synthesis of Tetracycles Mediated by a Cobalt-Complexed Alkyne

Elsa Hinds and Zulema Peralta

The ultimate goal of this project is to cobalt-complex tetraenynes, **12**, which will promote a tandem Diels-Alder/Pauson-Khand reaction to form tetracycle **14**. Previous work on this project developed the current synthetic scheme and the plan for this summer was to continue the scheme in hope of synthesizing acyclic precursor **12**. Previous work had successfully synthesized **1-7**. Summer work focused on optimizing the Sonogashira reaction (**6-7**) and Suzuki coupling forming **8**. Once **8** was formed, the synthesis would continue with steps previously completed on a similar acyclic precursor.

Optimization of the Sonogashira reaction on **6** was imperative because previously the largest yield was 50%, which in a 10-step synthesis is not optimal. To accomplish this, different purification conditions were employed via column chromatography as well as changing the palladium catalyst from $\text{Pd}(\text{PPh}_3)_4$ to bench-stable $\text{Pd}(\text{PPh}_3)_2\text{Cl}_2$. Toward the end of the summer the Ph substrate was changed to a TMS group, and the purification was simple. While the Sonogashira conditions were being optimized, Suzuki reactions were being performed on pure **7**, and the Ph Sonogashira product yielded pure **8** after optimization with base conditions. Once the pure TMS **7** was available, Suzuki reactions were attempted to no avail. This was likely due to the fact that TMS alkynes are frequently deprotected in base conditions so a third, alkyl substrate has been tested with success in the Sonogashira. Once the Sonogashira is optimized, steps toward **12** will continue in the fall. (Supported by the Howard Hughes Medical Institute and American Chemical Society Fellowship)

Adviser: Kevin Shea

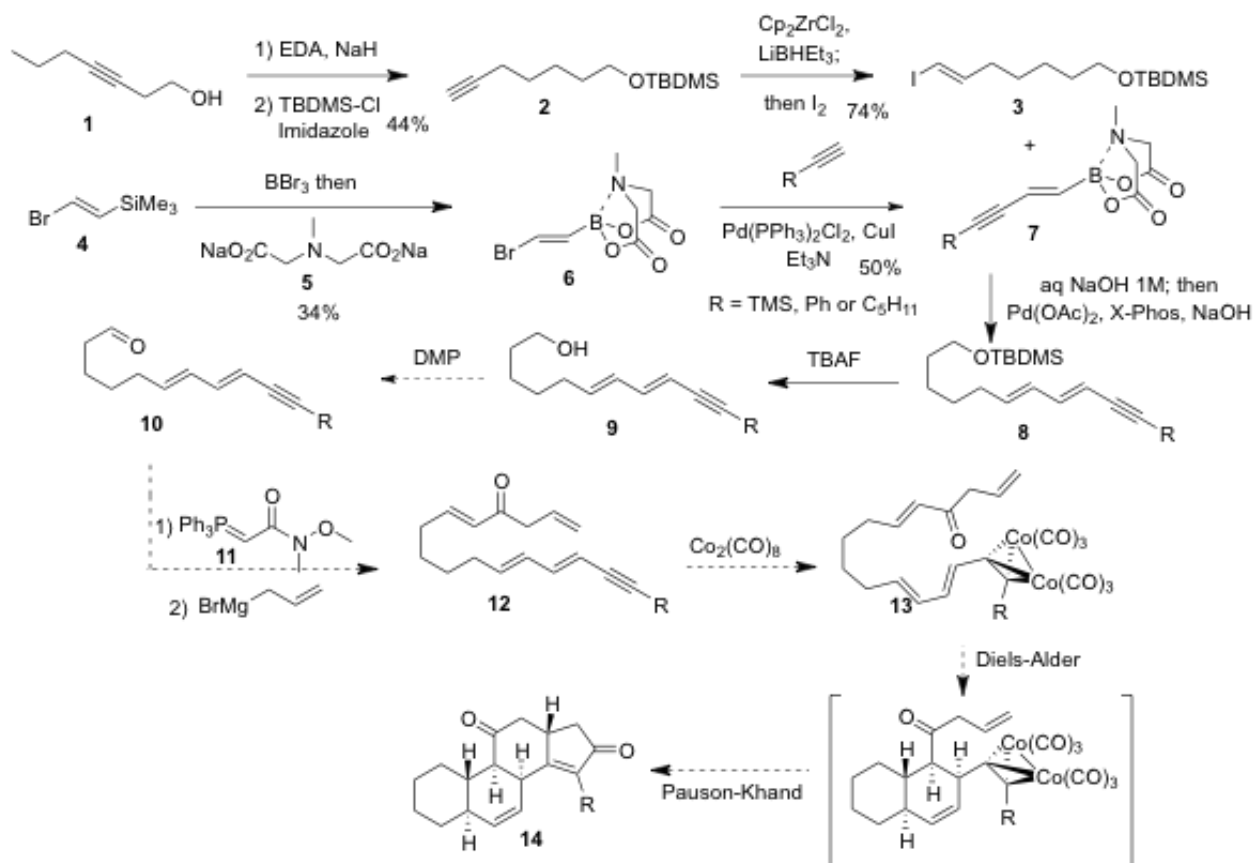

Selective Catalytic Chemistry Using DNA Aptamers

V. Garbo Garborcauskas

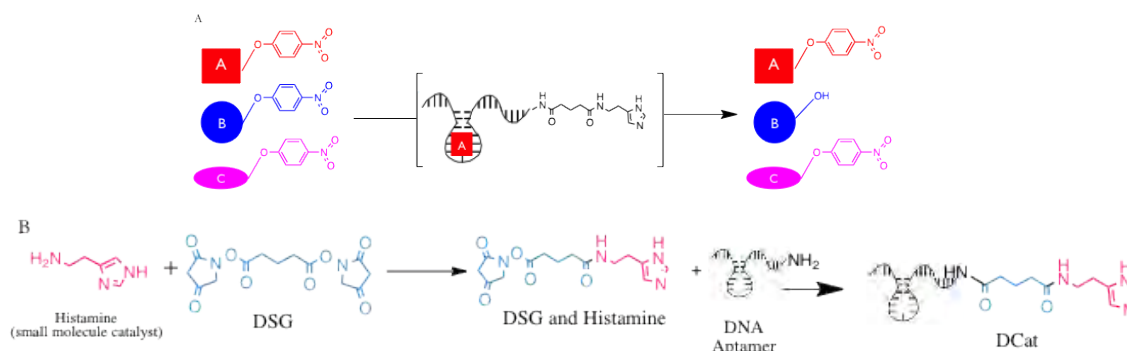

One of the greatest challenges to modern chemists is to chemically modify one target molecule in a mixture. A selective reaction of only the target molecule is very difficult because other background molecules in the mixture may have similar or identical functional groups and often react in the same way. Our goal is to only react the starting chemical with one of the molecules in the mixture, instead of all of them. (See Figure A above) Currently, although there are methods to selectively modify a target protein, this cannot be done for small molecules.¹¹ Our goal this summer was to use DNA-small molecule catalyst conjugates (DCats) to achieve selective chemistry. This will be something that no lab has ever been able to do with small molecules and could revolutionize biomedical sciences and biochemistry.

A DCat is made using a DNA aptamer that is targeted to the molecule selected for reaction. A DNA aptamer is an oligonucleotide that has an affinity to the target molecule. If the target molecule is cholic acid, the DNA aptamer used will have an affinity to cholic acid. Attached to the DNA is a linker (DSG in figure B above). The linker enables attachment of a small molecule catalyst, which catalyzes a reaction of interest, to the DNA aptamer (See Figure A above). A small molecule catalyst can be many different molecules or functional groups, however, since we initially wish to perform a hydrolysis reaction, an imidazole group was chosen. This summer, we had three experimental goals: synthesis of the first DCat, the development and optimization of methods to monitor the desired reaction and testing the first DCat for selective catalysis.

This summer, the first ever DCat was synthesized. The linker, DSG, was first reacted with the small molecule catalyst, histamine. DNA was then added to the mix, allowing the amine functional group on the DNA to react with the linker. After running the reaction for more than four hours, there was a combination of three different possible molecules in the reaction mix. It is possible to get the DNA aptamer back, the DNA aptamer with the linker, or the desired product: the DNA aptamer with the linker and the small molecule. These three different molecules separate out on a reverse phase high-pressure liquid chromatography C18 silica column (HPLC). The ratio and amount of time these solvents flow through the column can lead to complete separation, or only partial separation. This summer, time was spent optimizing this method to allow for complete separation of the three different molecules. Conditions were found to separate out the different molecules without any overlap from the previous molecule, giving a pure product.

Methods were developed this summer to monitor the progress of the reaction while it is running. One of the instruments in the Center for Molecular Biology was particularly helpful: the nanodrop spectrophotometer. Most spectrophotometers use a large volume (>2mL) to measure the wavelength of light allowed to go through the liquid, however, the DCat reaction is run in very small volumes, only 20µL. The nanodrop spectrophotometer uses 2µL for each reading and gives a UV spectrum absorbance. Before the DCat reaction could be started, standard curves of the byproduct, nitrophenol, the starting material and the desired product needed to be created so that the formation of the byproduct and how much starting material was left could be monitored throughout the DCat reaction on the nanodrop spectrophotometer. Another possible way to monitor reactions when they are finished is to run them through the HPLC to determine the final concentration of byproducts, starting materials and desired products and to adequately separate them out. Since the DCat is a catalyst, recovering the DCat is possible, using an instrument that separates out the different molecules. In order to determine how much DCat, starting material, byproduct and desired product there is in a reaction, it was necessary to create standard curves on the HPLC. All of these experiments were preliminary tests before the DCat reaction could run in order to effectively monitor the progress and the end of the reaction.

Once the DCat has been synthesized, reactions were started with them to see if selective chemistry occurred. The DCat reactions were monitored with the nanodrop spectrophotometer. The nanodrop spectrophotometer gives a reading of UV light absorbance at a certain wavelength. Since the desired product has a known reading at 410 nm, the formation of the product can be monitored, and using standard curves, the amount of turnover can be calculated.

With the cholic acid DCat, a selective reaction was observed however, with the ibuprofen DCat, there was only a very slow hydrolysis reaction. In the near future, the goal of the Gorin lab is to create more and different types of DCats expanding the amount and type of selective chemistry that will be able to be reacted. (Supported by the Howard Hughes Medical Institute)

Advisor: David Gorin

References:

¹Gorin, David J. 2011. Selectivity in Complex Contexts: Directing Chemical Reactions with DNA-Small Molecule Conjugates. Single Investigator Cottrell College Science Award Application.

Ion Transport of Extruded Liposomes as Cell Membranes

Esther Hong

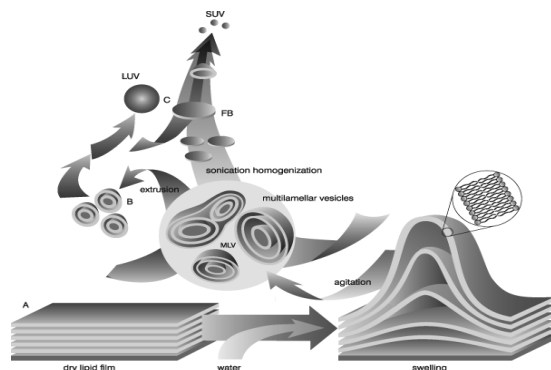

Phospholipids are a type of lipids containing a hydrophilic polar head and hydrophobic tails. Phospholipids are important because they can be found in biological membranes. These lipids create a barrier for the passage of hydrophilic material, such as water and ions. In the presence of water, lipids form vesicles, or liposomes, which act as model cell membranes. This summer I examined a set of novel synthesized cyclic peptides and their ionophoric activity.¹ These cyclic peptides can form a flat ring structure that can stack to form dimers. I studied the ion transport of these cyclic peptides by preparing liposomes and examining the mediated ion transport using ²³Na Nuclear Magnetic Resonance (NMR).

When first hydrated, most lipids form multilayered liposomes. I used extrusion to convert these multilamellar structures into unilamellar, or bilayer, systems to model cell membranes found in nature. Ion channels and transporters facilitate the transport of material and signals in and out of the cell. These regulate the flow of metal ions across cellular lipid bilayers. Cyclic peptides were then added to these liposomes in varying amounts and tested using NMR.

I used the prepared liposomes to test ionophores, including various cyclopeptides that can stack to form dimer ionophores and gramicidin, a known ion transporter as a standard by which to judge the efficiency of the cyclic peptides.¹ I compared changes over time in NMR peaks that indicate the concentration of ions in and out of the liposomes². Increasing intracellular ion concentration indicates that the ionophore is effectively transporting ions from the higher extracellular concentration to the lower intracellular concentration. Initial tests show immediate concentration changes that plateau over time, suggesting that the tested cyclic peptides have an ion channel-like mechanism.³

Discovering new compounds that have the ability to transport ions across cell membranes well can aid in the medical field, helping form new antibiotics that can have a faster effect on the human body. Determining if the tested cyclic peptides can be used as ion channels can lead us in a direction to possibly implement them for use in the future. I have presented my research to fellow students and will continue with my project in the fall. (Supported by the Howard Hughes Medical Institute)

Advisor: Cristina Suarez

References:

- ¹Amorin M., Castedo, Luis., Granja, J.R. (2008) Folding Control in Cyclic Peptides through N-Methylation Pattern Selection: Formation of Antiparallel β -Sheet Dimers, Double Reverse Turns and Supramolecular Helices by $3\alpha,\gamma$ Cyclic Peptides. *Chem.Eur.J.* 14:2100.
- ²Jin, T.; Kinjo, M.; Koyama, T.; Kobayashi, Y.; Hirata, H. *Langmuir* (1996) Selective Na^+ Transport through Phospholipid Bilayer Membrane by a Synthetic Calix[4]arene Carrier, 12: 2684-2689.
- ³Herasymova, N. (2010) Gramicidin A and Cyclic Peptide Channel Conductances in Black Lipid Membranes. (Honors Thesis, Smith College, 2010).

Energetic Comparison of S_N2 Self-Exchange Reactions on Pentacoordinate Carbon, Silicon, and Tin

Sarah Kay

Though carbon structures have been extensively studied in organic chemistry, relatively little is known about the analogous silicon or tin structures and whether these elements will behave similarly, given differences in size and nuclear charge. This project investigated the resultant energy changes when a ligand, XH_n^- , displaces an identical ligand from a methyl, silyl, or stannyl center via an S_N2 mechanism. Using ADF2012¹ many such systems were investigated, in which X is an element from rows 2-5, groups 14-17 of the periodic table. In each system, three structures were examined: the XH_n^- anion, the CH_3XH_n molecule (or Si or Sn), and the trigonal bipyramid $[XH_n-CH_3-XH_n]$. The sum of total bonding energies (TBE) for the anion and molecule was subtracted from the TBE of the overall system, giving the reaction energy from infinite separation of the starting fragments.

The most significant finding is that while the energy change for the methyl-centric system is nearly always positive (a barrier), the change in both silyl-centric and stannyl-centric systems is consistently negative (energy wells). I.e. the trigonal bipyramid for SiH_3 and SnH_3 self-exchange reactions (SER) are stabilizing, while the same structure for CH_3 SER's is destabilizing. These results support a paper² published by Hoz; starting from a dipole attraction of the initial fragments (rather than infinite separation), Hoz found that the CH_3 systems are always uphill in energy.

The trends observed show that elements farther to the right in the periodic table (i.e. halides) form the most stable pentacoordinate systems (for C, Si, and Sn). However, while silicon and tin favor the upper rows (C, N, O, F are best), carbon shows the smallest barriers with the largest elements (Sn, Sb, Te, I) as ligands. (Supported by Smith College Committee on Faculty Compensation and Development)

Advisor: Robert Linck

References:

¹ADF2012, SCM, Theoretical Chemistry, Vrije Universiteit, Amsterdam, The Netherlands, <http://www.scm.com>. E.J. Baerends, T. Ziegler, J. Autschbach, et al.

²S. Hoz, H. Basch, J. L. Wolk, T. Hoz, E. Rozental, J. Am. Chem. Soc. 1999. 121, 7724-7725.

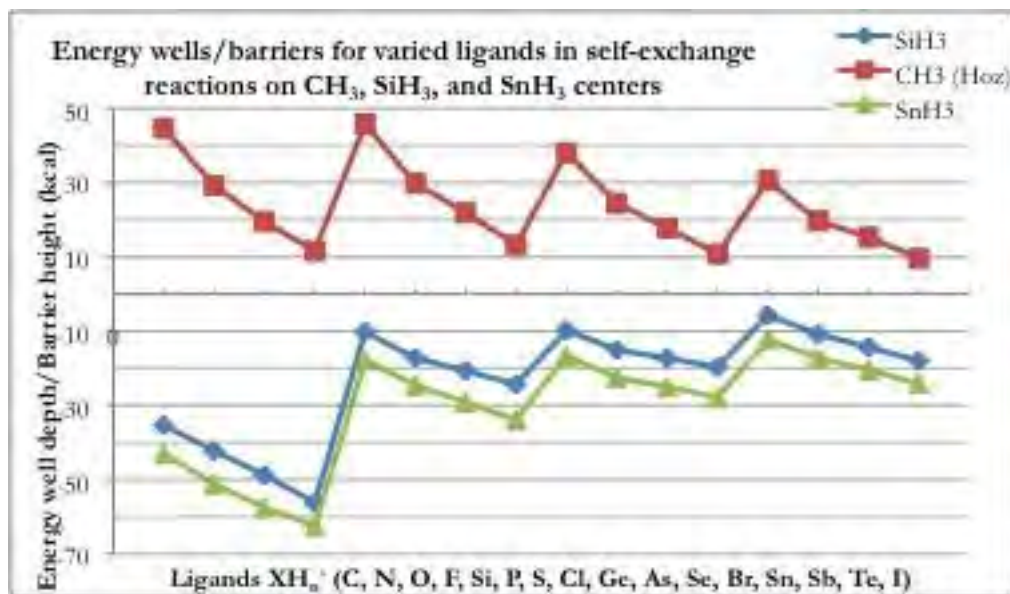

DCats: Synthetic Tools for Selective Chemistry in Complex Settings

Jiyeon Kim

.....

In response to a growing interest for chemical transformations *in vivo* and other complex environments, reactions that can selectively transform one target compound in a mixture are becoming high in demand. Currently, strategies for modifying a specific compound in the presence of similar compounds are mostly limited to proteins and have yet to be discovered for all other classes of molecules including small molecule metabolites, natural proteins, and sugars.¹ In the Gorin Lab, we synthesize and utilize DNA small molecule catalysts (DCats) to achieve site-selective chemistry. A DCat is modularly assembled from a DNA aptamer and a small molecule catalyst. An aptamer is an oligonucleotide that binds to a specific molecule with strong affinity through specific base coding and conformation.² Whereas in traditional chemistry a catalyst transforms all compounds with a susceptible functional group in a mixture, a DCat will speed up and direct a reaction to its target molecule while leaving other non-targets unchanged (Figure 1).

This summer, I synthesized various DCats, optimized methods for product purification, and tested a DCat's proof of concept. The first successful synthesis was a DCat for the hydrolysis of cholic acid nitrophenol ester. An aptamer for cholic acid with an amine at the 5' end, previously evolved by SELEX,³ went through a carbonyl substitution with an excess amount (>10⁴ equivalents) of di(N-succinimidyl) glutarate (DSG) modified with histamine at one end (Figure 2A). DCats with non-catalysts were also synthesized in the same fashion (Figure 2B). The DCats were then purified by high-pressure liquid chromatography (HPLC) in the Center of Proteomics. Our initial method gave mixed fractions of the products; thus we optimized the method and were successful in purifying the desired DCats. The products were furthermore characterized by mass spectrometry also in the Center of Proteomics. DCats for the hydrolysis of ibuprofen nitrophenol ester were also synthesized and purified.

With the DCats in-hand, I was equipped to test the selectivity of these special catalysts. The lab's hypothesis, as illustrated in Figure 3, was that a DCat would speed up a reaction to its target molecule by bringing the target closer to the catalyst via the aptamer, increasing the probability of the two molecules reacting. Various reactions were prepared in necessary buffered salt solutions (Figure 3). The rate of reaction was quantified by checking the concentration of nitrophenol by UV-Vis at various times and comparing with a standard curve prepared. Initial results have been inconclusive.

In the 2012-13 academic year, I will expound on the work I've accomplished during SURF through a senior honors thesis. First, I will follow-up on the results of our DCat reactions, drawing conclusions to develop the next steps for the project. For example, I will experiment with the linker between the aptamer and the catalyst to investigate if there is enough flexibility for the catalyst to reach the target. I will also develop other ways of monitoring the reactions. Additionally, I will investigate the effect of certain salts in the reaction buffer. These experiments will pave the road in validating DCats as synthetic tools for selective chemical reactions in complex environments. (Supported by the Trilink Biotechnology Research Rewards Program, the Cottrell College Scholar Award, and Smith College's SURF Program)

Advisor: David Gorin

References:

¹Tsien, R. Y. "Constructing and exploiting the fluorescent protein paintbox." *Angew. Chem. Int. Ed.* **2009**, *48*, 5612.

²Wochner, A.; Menger, M.; Orgel, D.; Cech, B.; Rimmel, M.; Erdmann, V. A.; Glokler, J. "A DNA aptamer with high affinity and specificity for therapeutic anthracyclines." *Anal. Biochem.* **2008**, *373*, 34.

³Wilson, D. S.; Szostak, J. W. "In vitro selection of functional nucleic acids." *Ann. Rev. Biochem.* **1999**, *68*, 611.

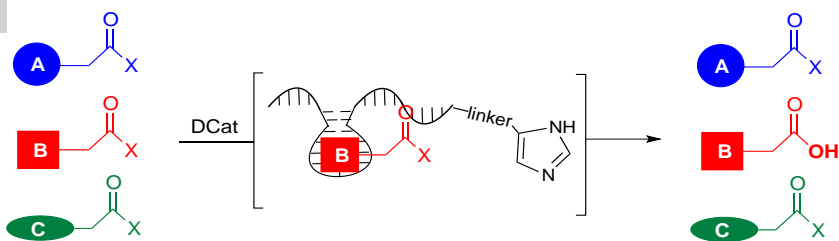

Figure 1. DCat-mediated selective hydrolysis to target molecule B

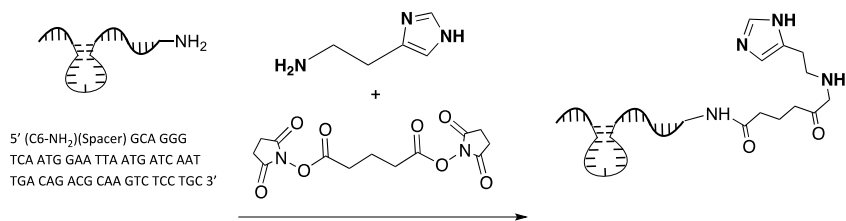

Figure 2A. Synthesis of cholic acid hydrolysis DCat

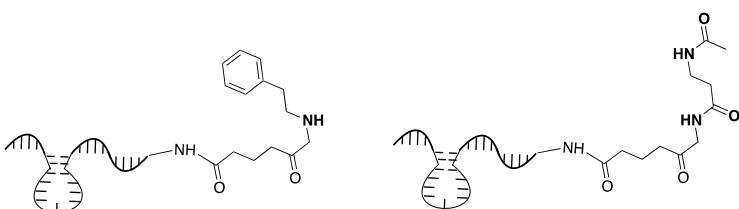

Figure 2B. Control DCat with phenethylamine (left) and control DCat with glycyl glycine ethyl ester (right), synthesized in the same way

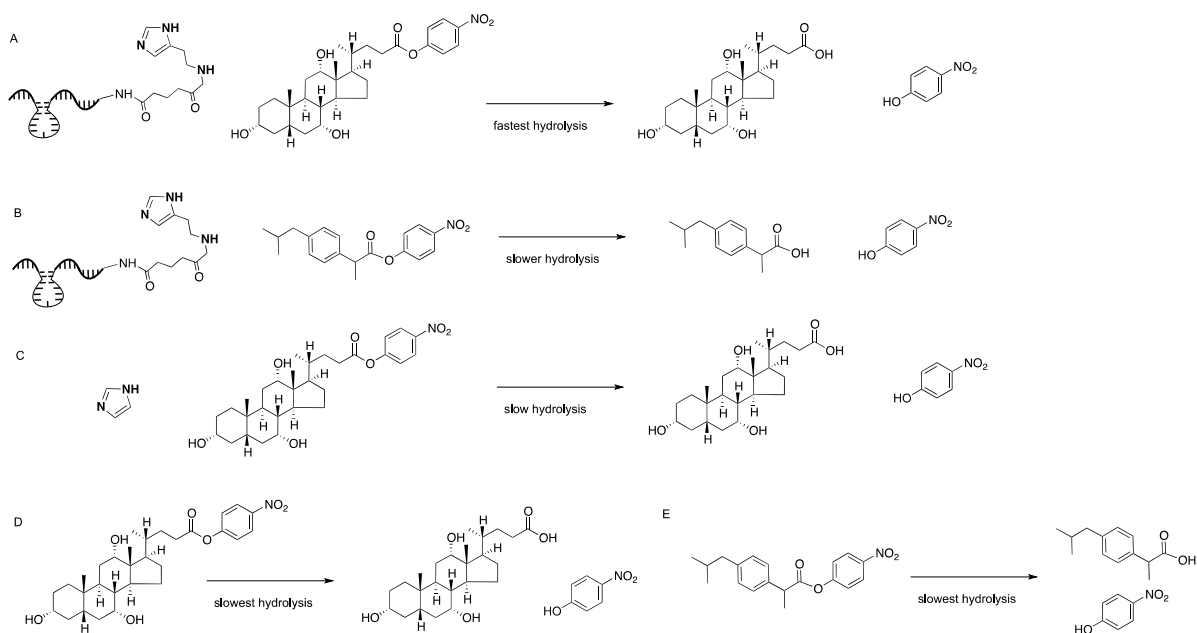

Figure 3. Preliminary DCat reactions with predicted rate of hydrolysis. A) Cholic Acid DCat with cholic acid nitrophenol ester. B) Cholic acid DCat with ibuprofen nitrophenol ester. C) Imidazole with cholic acid nitrophenol ester. D) Cholic acid nitrophenol ester alone. E) Ibuprofen nitrophenol ester alone.

A ^{39}K -NMR Study of the Encapsulation of Potassium in Phosphatidylcholine Liposomes

Colby R. Loew

.....

The objective of this project is to confirm the encapsulation of potassium cations in phosphatidylcholine liposomes through implementation of ^{39}K -NMR. With working ^{39}K -NMR acquisition parameters established, distinct intra- and extra-liposomal concentrations of potassium should be apparent upon the introduction of dysprosium as a shift reagent to the liposome sample. The existence of two potassium environments as evidenced by ^{39}K -NMR will become paramount as the eventual goal is to examine the cyclic peptide ionophore valinomycin for its ability to transport cations across the phospholipid bilayer.

As NMR was employed in this study, certain acquisition parameters proved to be imperative. The receiver gain is the degree to which the signal coming from the sample is amplified and is much like the volume dial on a radio. When the receiver gain is set too high, the FID becomes clipped which may lead to baseline distortions in the processed spectrum. A signal that is too strong may also result in an "overflow" error of the receiver or analog to digital converter (ADC). Moreover a gain that is set too low causes part of the sample signal to be lost. The pre-scan-delay time (DE) is the time in microseconds between the last pulse and the beginning of data acquisition with the purpose of avoiding pulse feed through. If the pre-scan-delay time is not long enough, a residual signal from the pulse may cause an overflow error. Through experimentation, values for these parameters were determined so that ^{39}K -NMR data acquisitions were made using a DE value of 20 μsec and gain of 10.

The formation of vesicles is spontaneous upon hydration of a dry lipid film. In the presence of an aqueous solution, phospholipids will spontaneously arrange so that the hydrophobic tails become isolated from the polar solvent using the hydrophilic head groups as a barrier. These hydrophobic contacts are the principal interactions that promote the construction of the lipid bilayer of the vesicle. Using a previously established extrusion protocol, phosphatidylcholine was hydrated in 200 mM KCl to form liposomes. Upon introduction of dysprosium as a shift reagent, intra- and extra-liposomal potassium peaks have not consistently become apparent in different sample preparations. In order to continue this study, the samples must be reliable in producing two separate cation environments. As part of an honors project, I plan to continue this research project in hopes of realizing the goal of using the potassium liposomes to study the transport abilities of the ionophore valinomycin. (Supported by the Howard Hughes Medical Institute)

Advisor: Cristina Suarez

Cuprous Oxide Nucleation Density Investigation with Various Morphologies for Clean Energy Applications

Lauren Magliozzi and Jennifer Weng

Cuprous oxide (Cu_2O) is a direct bandgap semiconductor that has been studied recently for various applications including solar energy conversion, gas sensors, CO and propene oxidation, and an anode materials for Li ion batteries.¹ It is a highly promising material for applications in solar energy conversion because of its band gap size ($E_g = 1.9\text{-}2.2$ eV) and relatively high absorption in the visible region.² However, the development of Cu_2O as an efficient material for solar energy conversion is a process still in its early stages.

Thin film Cu_2O was deposited in cubic, octahedral, and truncated morphologies by electrodeposition. Our goal was to deposit densely packed cubic (A-C), octahedral, (D-F) and truncated (G) morphologies. A crystal micrograph was taken of (A) to show the general color and shape of unmodified Cu_2O . We found that additives (SDS; Na_2SO_4), pH, temperature, and deposition potential affected shape the most. We found that silver pre-deposition conditions were the most significant regulators of film density.

We saw increased density as a result of increased negative potential and time of silver pre-deposition, as seen in (D-F). This initial pre-deposition of silver nanoparticles on the ITO surface is a means to control nucleation density through increasing sites for the nucleation of Cu_2O . Too much time or potential in this stage of synthesis created larger silver particles, inhibiting uniform and even growth of Cu_2O films.

We will apply what we learned from the conditions that produced the high nucleation density octahedral Cu_2O film (F), to create similarly dense films of the other morphologies. Figures C and G show films of cubic and truncated shapes of moderate density which can be improved upon. The high nucleation density films will be used by the Read lab in future studies of comparing photocurrent and surface properties of the different Cu_2O morphologies. (Supported by the Schultz Foundation)

Advisor: Carrie G. Read

References:

¹Jang, Ho Seong, Suk Jun Kim, and Kyoung-Shin Choi. 2010. Construction of Cuprous Oxide Electrodes Composed of 2D Single-Crystalline Dendritic Nanosheets. *Small*, 6: 2183-190.

²Akimoto, K., S. Ishizuka, M. Yanagita, Y. Nawa, G. Paul, and T. Sakurai. 2006. Thin Film Deposition of Cu_2O and Application for Solar Cells. *Solar Energy*, 80: 715-22.

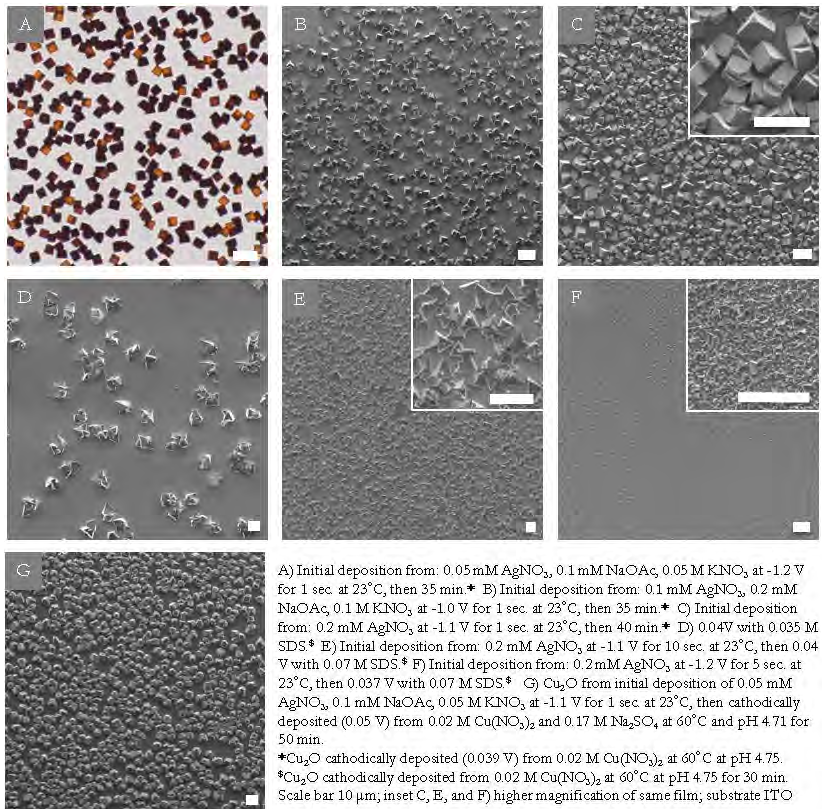

A) Initial deposition from: 0.05 mM AgNO₃, 0.1 mM NaOAc, 0.05 M KNO₃ at -1.2 V for 1 sec. at 23°C, then 35 min.* B) Initial deposition from: 0.1 mM AgNO₃, 0.2 mM NaOAc, 0.1 M KNO₃ at -1.0 V for 1 sec. at 23°C, then 35 min.* C) Initial deposition from: 0.2 mM AgNO₃ at -1.1 V for 1 sec. at 23°C, then 40 min.* D) 0.04V with 0.035 M SDS* E) Initial deposition from: 0.2 mM AgNO₃ at -1.1 V for 10 sec. at 23°C, then 0.04 V with 0.07 M SDS.* F) Initial deposition from: 0.2 mM AgNO₃ at -1.2 V for 5 sec. at 23°C, then 0.037 V with 0.07 M SDS.* G) Cu₂O from initial deposition of 0.05 mM AgNO₃, 0.1 mM NaOAc, 0.05 M KNO₃ at -1.1 V for 1 sec. at 23°C, then cathodically deposited (0.05 V) from 0.02 M Cu(NO₃)₂ and 0.17 M Na₂SO₄ at 60°C and pH 4.71 for 50 min.
 *Cu₂O cathodically deposited (0.039 V) from 0.02 M Cu(NO₃)₂ at 60°C at pH 4.75.
 *Cu₂O cathodically deposited from 0.02 M Cu(NO₃)₂ at 60°C at pH 4.75 for 30 min.
 Scale bar 10 μm, inset C, E, and F) higher magnification of same film, substrate ITO

Effects of Hydrogen-Bonding on O-H Stretch Overtone Excitation for Fluorinated Hydroperoxides

Mojdeh Mostafavi and Julie Vallejo

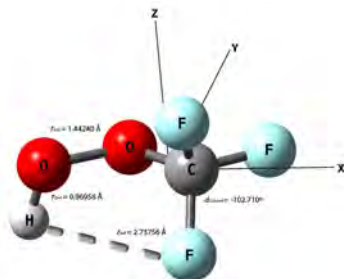

Hydrofluorocarbons, also known as HFCs, are molecules that currently serve as refrigerants and as chlorofluorocarbon (CFC) replacements. Hydrogen containing HFCs have shorter atmospheric lifetimes than CFCs, since H atom abstraction by OH radicals leads to their oxidation in the troposphere before the molecules can find their way upwards to the stratosphere.^{1,2} Laboratory studies predict that O₂ can convert the alkyl radicals, formed from the reaction between HFCs and OH radicals, into peroxy radicals that can then react with HO₂ radicals to form hydroperoxides in the atmosphere.² Here we focus on the effect of increased fluorination on the absorption spectra in the visible wavelength region for these atmospheric hydroperoxides, in comparison to their non-fluorinated analogs.

As a first step in predicting absorption spectra, Gaussian09 calculations were used to find the most stable conformers of the molecules of interest: CF₃OOH, CHF₂OOH, CH₂FOOH, and CH₃OOH. For each conformer, we performed calculations of energies, dipole moment components and O-H stretch frequencies. Because previous studies on hydroperoxides have shown absorption in the visible wavelength region to correspond to excitation of O-H stretch vibration and torsion about the O-O bond, calculations were extended to C-O-O-H dihedral angles every 10°, from 0° to 360°.³ At each torsional angle, calculations were gathered with six compressed and six extended O-H bond lengths in 0.05 Å steps around the equilibrium value. The information gathered with Gaussian09 was then used to predict absorption spectra using methods developed previously.³

In comparing the series, we found that intramolecular hydrogen bonding between the O-H and fluorines causes the fluorinated organic hydroperoxides to behave differently from the non-halogenated species. The presence of hydrogen bonding was evident in the relative stability of conformers, anti and gauche. In some molecules, the gauche conformer was more stable than the anti. The ones with stable gauche conformations had the hydroperoxide hydrogen in proximity to a fluorine, indicating that hydrogen bonding was responsible for the increased stability of what is typically thought as the unstable conformer. As more fluorines were added, the hydroperoxides also showed a higher O-O bond dissociation energy and lower O-H frequency, which both work against overtone in the atmosphere.⁴ (Supported by a Henry Dreyfus Teacher-Scholar Award and the National Science Foundation).

Advisor: Shizuka Hsieh

References:

- ¹McCulloch, A.; *Journal of Fluorine Chemistry*. 1999. 100. 163-173.
- ²Sehested, J.; Møgelberg, T.; Fagerström, K.; Mahmoud, G.; Wallington, T. J. *International Journal of Chemical Kinetics*. 1997. 29. 9. 673-682.
- ³Haynes, L. M.; Vogelhuber, K. M.; Pippen, J. L.; Hsieh, S. *J. Chem. Phys.* 2005. 123. 234306.
- ⁴Donaldson, D. J.; Tuck, A. F.; Vaida, V. *Chem. Rev.* 2003, 103, 4717-4729.

The Stability of Four Coordinate Sulfur Compounds and Five Coordinate Phosphorus Compounds

Chioma Nwonu

Four coordinate sulfur compound consists of 4 ligands attached to the central atom, S. Sulfur has 6 valence electrons, 4 of which are involved in bonding, and the other two which form a lone pair of electrons. This gives a see-saw shape with S in the centre, 2 ligands and the lone pair in the equatorial position, and then 2 ligands in the axial position (Figure 1).

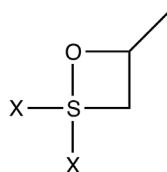

Figure 1

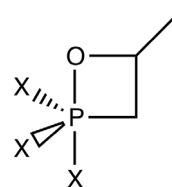

Figure 2

This research focused on the stability of the compounds formed by interchanging the elements: F, OH, NH₂, CH₃, and NC on the axial and equatorial positions. The presence of the lone pair of electrons pushes the equatorial angle less than the ideal 120° and the axial angle less than the ideal 180°. The results show that the more electronegative ligands occupy the axial positions to form the most stable compounds, as shown by the energy of the different compounds; SFO₂C₃H₇ with F and OH in the axial positions has energy of -767.13 a.u., while SO₃C₃H₉ with OH and OH in the axial positions has energy of -743.06 a.u. The five coordinate phosphorus compounds consist of 5 ligands attached to the central atom, P. The five valence electrons in P are all used in bonding, hence no lone pair. This gives a trigonal bipyramid shape with 3 equatorial ligands and 2 axial ligands (figure 2).

The ligands are interchanged in a similar way as those of the sulfur compound. The results obtained are similar; the most stable compounds, as shown by the energy of the different compounds, have the most electronegative ligands in the axial position. I plan to continue this research with six coordinate sulfur compounds because they have no lone pair of electrons. (Supported by the Schultz Foundation)

Advisor: Robert Linck

References:

¹Gaussian 09, Revision A.1, M. J. Frisch, G. W. Trucks, H. B. Schlegel, G. E. Scuseria, M. A. Robb, J. R. Cheeseman, G. Scalmani, V. Barone, B. Mennucci, G. A. Petersson, H. Nakatsuji, M. Caricato, X. Li, H. P. Hratchian, A. F. Izmaylov, J. Bloino, G. Zheng, J. L. Sonnenberg, M. Hada, M. Ehara, K. Toyota, R. Fukuda, J. Hasegawa, M. Ishida, T. Nakajima, Y. Honda, O. Kitao, H. Nakai, T. Vreven, J. A. Montgomery, Jr., J. E. Peralta, F. Ogliaro, M. Bearpark, J. J. Heyd, E. Brothers, K. N. Kudin, V. N. Staroverov, R. Kobayashi, J. Normand, K. Raghavachari, A. Rendell, J. C. Burant, S. S. Iyengar, J. Tomasi, M. Cossi, N. Rega, J. M. Millam, M. Klene, J. E. Knox, J. B. Cross, V. Bakken, C. Adamo, J. Jaramillo, R. Gomperts, R. E. Stratmann, O. Yazyev, A. J. Austin, R. Cammi, C. Pomelli, J. W. Ochterski, R. L. Martin, K. Morokuma, V. G. Zakrzewski, G. A. Voth, P. Salvador, J. J. Dannenberg, S. Dapprich, A. D. Daniels, Ö. Farkas, J. B. Foresman, J. V. Ortiz, J. Cioslowski, and D. J. Fox, Gaussian, Inc., Wallingford CT, 2009.

Impact of the Oxidized Guanine Lesion Spiroiminodihydantoin on the Thermodynamic Stability of DNA

Hanyu Shi

The oxidation of DNA bases has been found to be a potential factor in Alzheimer's, cancer, cellular aging and other neurological disorders.¹ Guanine is the most easily oxidized of the four standard DNA bases because of its reduction potential and can be oxidized to form 7,8-dihydro-8-oxo-2'-deoxyguanine (8-oxoG). Further studies show that the 8-oxoG may be further oxidized by reactive oxygen and nitrogen species as well as high-valent metals,² such as Cr(VI) and Ir(IV), to form spiroiminodihydantoin (Sp) lesion. The chiral carbon at the spiro center of the Sp lesion creates R and S enantiomers that become a pair of diastereomers when bonded to the furanose ring DNA. This stereochemistry gives the lesion a unique structure that has the potential to greatly impact the stability and biological processing of DNA. Although the Sp lesion has been studied in nucleosides, nucleotides and *in vitro* systems, little is known about the role of the Sp lesion in complex biological systems.

My project is a collaborative study between Professor Jamieson and Mount Holyoke College Professor, Megan Núñez to study DNA damage in complex biological systems. The project explores and examines whether Sp lesion site-specifically introduced into a DNA oligonucleotide construct will thermodynamically change the formation of nucleosomes. The question we ask is what effect the Sp lesion will have on the affinity of histones for DNA, and whether the lesion will change the rotational phasing of the nucleosome on the DNA. Two 20-mer oligonucleotide sequences containing 8-oxo-G (one at 7 position and one at 12 position) were ordered from TriLink BioTechnologies. The Sp lesion was synthesized by reacting sodiumchlorideiridate(IV) (Na_2IrCl_4) with the 8-oxo-G oligonucleotides. The Sp lesion generates two diastereomers, which were purified and collected by HPLC, then confirmed by Mass Spectroscopy.

Further studies have already commenced. The confirmed diastereomers of the Sp lesion were sent over to Mount Holyoke College. Students in the Núñez work on synthesizing and assembling the Sp-containing DNA oligonucleotide constructs. The final Sp-lesion duplexes will be gel purified and radioactively labeled. The relative binding affinity of the histones for the DNA will be determined by gel shift assay, revealing whether the Sp lesions facilitate or hinder nucleosome formation. (Supported by the National Institutes of Health)

Advisor: Elizabeth Jamieson

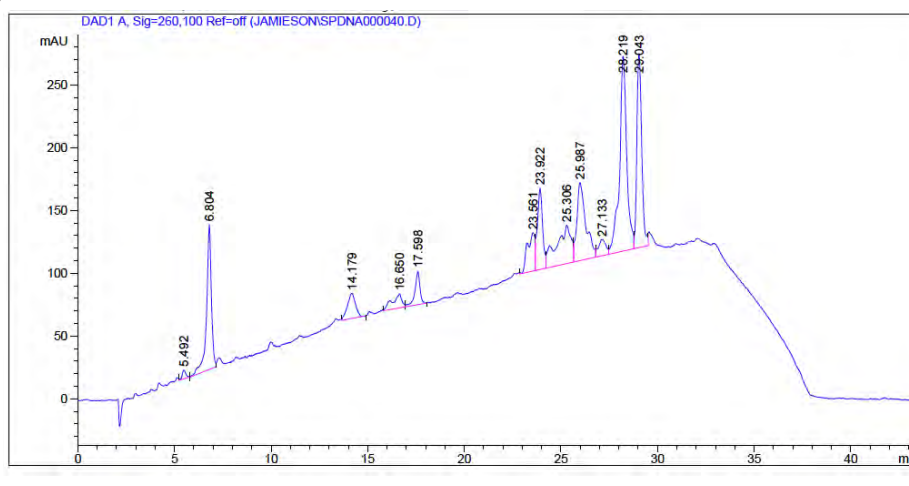

References:

¹Chinyeretere, F., Jamieson, E.R., Thermodynamic Impact of the Sp lesion, *Biochemistry* **2008**, *47*, 2584-2591.

²Sugden, K. D., Campo, C. K., and Martin, B. D. (2001) Direct oxidation of guanine and 7,8-dihydro-8-oxoguanine in DNA by a high-valent chromium complex: a possible mechanism for chromate genotoxicity, *Chem. Res. Toxicol.* *14*, 1315-1322.

Purification and Synthesis of 2,6-dimethylcyclohexanol and Similar Cyclohexanol Analogues for Application as General Anesthetics

Kelly Smith

This research in collaboration with the Adam Hall Laboratory focuses on the importance of cyclohexanol derivatives as possible general anesthetics. Cyclohexanol compounds have a similar structure to propofol, a common anesthetic (Figure 1). Adam Hall has studied the effects of various cyclohexanols on GABAA (γ -aminobutyric acid type A), a receptor known to play a role in propofol activity. As a result, they discovered that 2,6-diisopropylcyclohexanol and 2,6-dimethylcyclohexanol were most effective (after propofol) as modulators of GABAA followed by cyclohexanol compounds with bulkier side chains. This research was conducted using a mixture of isomers for all compounds, but current research in this field points to the importance of stereochemistry in relation to a compounds effectiveness with GABAA and in the human body.

The three diastereomers of 2,6-dimethylcyclohexanol were separated via column chromatography, but the separation is extremely difficult we never attempted to separate enantiomers (**3** and **4**), (Figure 2). Therefore, asymmetric syntheses were utilized to selectively make trans,trans (**2**) as well as cis,trans (**3**) and trans, cis(**4**)

From (*Z*) and (*E*) 2,6-dimethylcyclohexanone (**5** and **6**). The diastereomers of 2,6-dimethylcyclohexanone were separated via column chromatography. The synthesis of **2** involves reduction with sodium borohydride mediated by β -cyclodextrin, which complexes with **5** to permit only axial attack to produce **2** (Figure 3). This complex uses host-guest interactions to promote axial attack. In comparison, **6** was reduced with sodium borohydride without need for β -cyclodextrin to synthesize isomers **3** and **4** (Figure 4). Isomer **1** can be readily isolated from the mixture of isomers of 2,6-dimethylcyclohexanol by column chromatography.

The next phase of this project involves synthesizing other 2,6-disubstituted cyclohexanol stereoisomers, including 2,6-diisopropylcyclohexanol and 2,6-diethylcyclohexanol, individually making all of the stereoisomers. These chiral molecules can then be studied for their individual effectiveness as anesthetics to generate new and different anesthetic molecules. (Supported by the Howard Hughes Medical Institute)

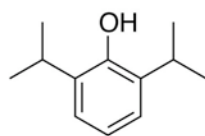

Figure 1. Propofol.

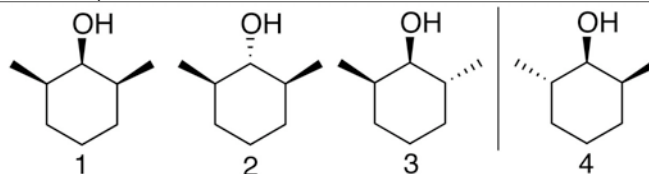

Figure 2. Stereoisomers of 2,6-dimethylcyclohexanol.

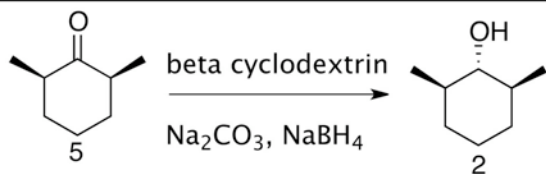

Figure 3. Selective Reduction of **5**.

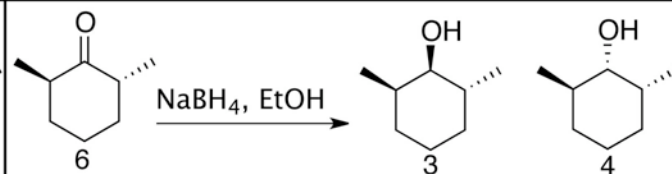

Figure 4. Reduction of **6**.

Advisor: Kevin Shea

Methyl Transfer of Oxygen Nucleophiles in Organic Synthesis

Yuan Ji and Jessica Sweeney

.....

Methylation is widely used in organic chemistry to synthesize molecules including polymers and pharmaceuticals. Common substrates to synthesize are phenols, carboxylic acids, and aliphatic alcohols. The goal of our research is to find safer and cost-effective reagents to perform methylation. Currently, the most common methods of methylation involve hazardous and highly toxic chemicals such as diazomethane. Diazomethane is explosive and must be synthesized using specialized glassware due to its instability. Exposure to current methylating agents has caused several deaths since 2008.¹

In our research, we methylated benzoic acid and phenol using dimethyl carbonate as a safe-alternative to diazomethane. We ran over one-hundred reactions this summer to determine the best conditions. Most reactions were run on a 25 mg scale. Various bases were screened with equivalents ranging from 1 to 0.1. We also screened a range of catalysts, solvents, and varied the temperature and duration at which these reactions were run.

Data obtained from screening were quantified using a gas chromatograph-mass spectrometer. By running samples containing known concentrations of our product along with an internal standard, we were able to construct standard curves that correlate GC signal integration with concentration of product.

We established the best conditions for methylating benzoic acid were using catalytic amounts of potassium carbonate (0.2 eq.) at 90°C for 72 hours. This reaction was run on a 100 mg scale. The product was isolated and an 81% yield was obtained. Another set of reactions were run using trimethyl orthoacetate in placement of dimethyl carbonate as the methylating agent.

Similar to the methylation of benzoic acid with dimethyl carbonate, starting conditions for methylation with orthoacetate included a catalyst, methylating agent, and starting material. We have had success with catalytic amounts of metal halides at a temperature of 90°C (73%). Lastly, methylation of phenol was also researched.

Much like the benzoic acid methylation, various bases, catalysts, and solvents were screened. Thus far, the best conditions for methylation of phenol with dimethyl carbonate include catalytic amounts of 1,2-dimethylimidazole and extreme heat (~150°C); these conditions gave a 74% yield. During the semester we hope to establish mild conditions for the methylation of benzoic acid with orthoacetate and the methylation of phenol by continuing to screen more catalysts, bases, and temperatures. After a successful ten weeks over 170 reactions were run and quantified. (Supported by the Howard Hughes Medical Institute)

Advisor: David Gorin

References:

- ¹Shieh, W.-C.; Dell, S.; Repic, O. "Nucleophilic catalysis with 1,8-diazabicyclo[5.4.0]undec-7-ene (DBU) for the esterification of carboxylic acids with dimethyl carbonate." *Journal of Organic Chemistry* 2002, 67, 2188-2191. b) Rekha, V. V.; Ramani, M. V.; Ratnamala, A.; Rupakalpana, V.; Subaraju, G. V.; Satyanarayana, C.; Rao, C. S. "A simple, efficient, green, cost effective and chemoselective process for the esterification of carboxylic acids." *Organic Process Research and Development* 2009, 13, 769-773. c) Carafa, M.; Mesto, E.; Quaranta, E. "DBU-Promoted Nucleophilic Activation of Carbonic Acid Diesters." *European Journal of Organic Chemistry* 2011, 2458-2465.

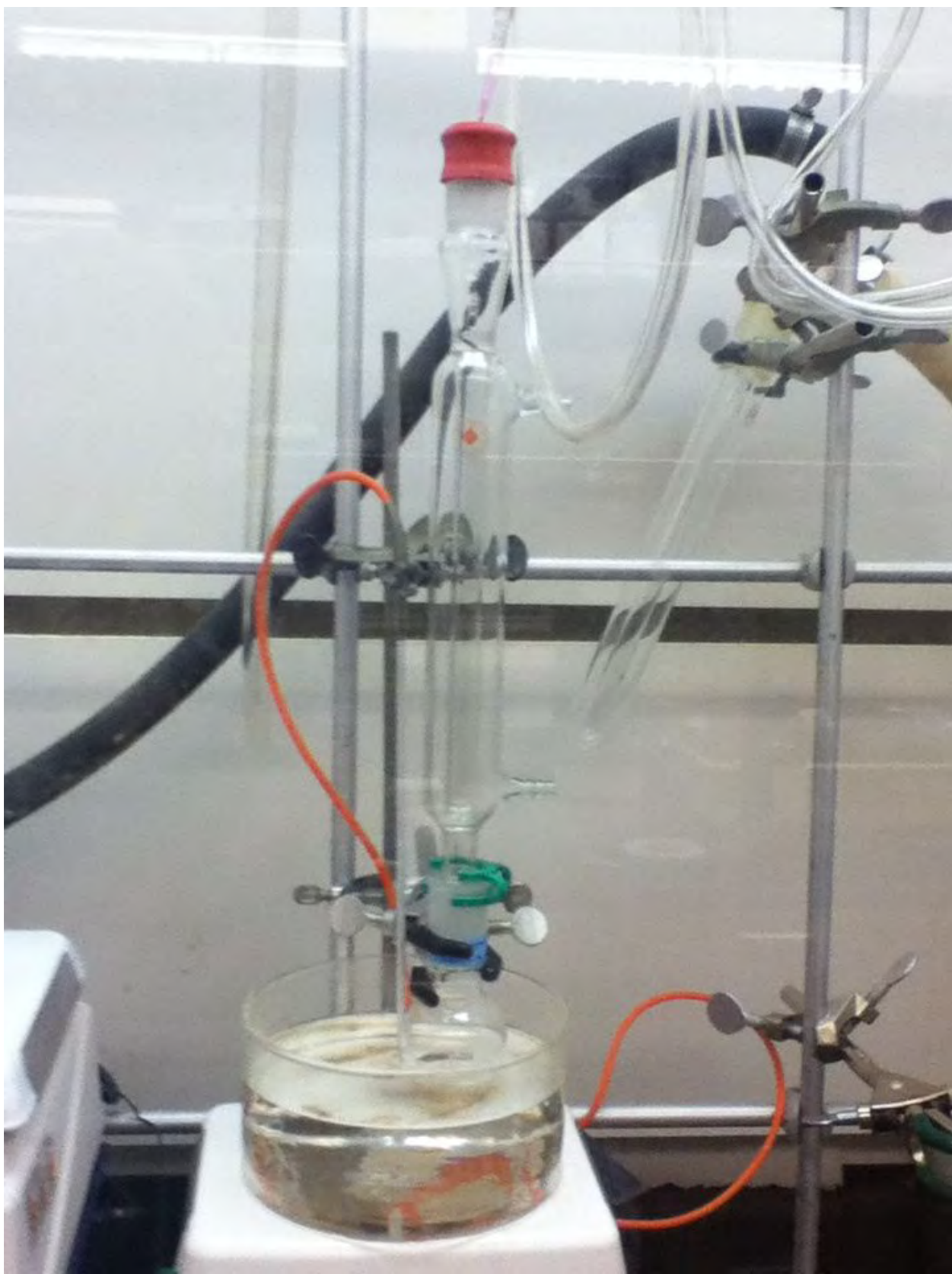

Chuck and the Keyboard Instruments Project

Lucy Chikwetu

Gone are the days when one had to wait for a day when thunder strikes, or a day when rain pours in order to record lightning or rain sounds. Digital music synthesis is enabling us to generate sounds when we need them. It is possible to make brass and clarinet compositions without touching either of those instruments. For six weeks of my summer, I was part of a team helping Professor Judy Franklin design a new computer science class that we believe will attract more women into the field. It is a course on digital sound synthesis using a computer music language called Chuck. We were also looking for other ways Chuck could be used in our daily lives. “Chuck it to the dac, just Chuck it to the dac!” became the song that we belted every time we wanted to take a break from programming and research in our laboratory, and *Chuck it* became a solution to all the problems we did not know.²

As part of our research, we had to understand the basics of sound, analog and digital sound recording, playing back sound, and digital sound synthesis methods. We had to synthesize our own sounds, look for ways Chuck has been used so far, and think of new ways to use it. Through the process came the discovery of using Chuck with keyboards, joysticks, and many other devices. That was a turning point of our work. I believed we could turn our keyboards into musical instruments. We could have our computer keyboards play sounds from a wide range of instruments such as the piano, clarinet, or brass. If we could do the project really well, the software could be distributed to various people, especially those who might not have the financial means to buy musical instruments, yet love music. The project was named the KINS Project. KINS stands for Keyboard Instruments. The basic components of our work are now functional, and other student researchers are carrying on this research. Below is the Graphic User Interface (GUI) of our project. The user simply selects the instrument to play and then types on her computer keyboard. The mapping is chromatic, using two octaves, and the “qwerty” row as the black keys on the piano.

In parallel we worked on course material that could help students who will take the class, including introductory examples, and slides shows. It was probably not supposed to be that much fun; but that is what always happens when scientists connect with their research and see what they do not only as a job, but as a way to make a difference. (Supported by the National Science Foundation)

Advisor: Judy Franklin

References:

¹A dac is a digital-to-analog converter, used to send sound out to the headphone or speaker port.

²The Chuck language uses an operator, =>, that is called the “Chuck it” operator.



The Hallway Project: An Interactive Application Based in ChuckK and Processing

Julia Edwards

This summer, I researched and developed applications based in the audio programming language ChuckK. One of my main projects was to develop an interactive program that explored the Open Sound Control (OSC) possibilities in ChuckK. We named this endeavor “The Hallway Project.”

Open Sound Control is a content format for sending messages between computers/multimedia devices or between two programs written in different programming languages. In my research, I used OSC to communicate between ChuckK and Processing, a graphics-oriented programming language. Together, the two programs process the volume of sound in a room and visually display that information as a rainstorm. Volume below a certain level corresponds to no rain falling, and increasing volume corresponds to increasing numbers of raindrops being produced per given time period. At a certain noise level, the “raindrops” turn into images of cats and dogs, until finally, if the room is extremely noisy, an image of a smiley face making a “shushing” gesture replaces the images of the cats and dogs.

I achieved this outcome using two ChuckK files and one Processing program. The first ChuckK file executes a Fast Fourier Transform (FFT) on an incoming audio signal taken from the ADC¹ (typically the computer’s built-in microphone), and extracts the volume of the sound. The second ChuckK program takes that number, wraps it into an OSC message, and sends it to the Processing program. The Processing program then uses that number to change the variable which controls the number of drops/images to be created at a given time interval, thus varying the intensity of the rainstorm. The flow chart below depicts this process. The Processing program contains many variables that control various aspects of the display. These aspects include: the color of the raindrops; the ratio of a drop’s height to its width (useful for changing the rain into snow flakes); how often new raindrops are produced; how often the volume of sound in the room is analyzed (so that the intensity of the storm doesn’t change constantly – this is primarily for realism.) (Supported by the National Science Foundation)

Advisor: Judy Franklin

References:

¹An ADC is an Analog to Digital Converter.

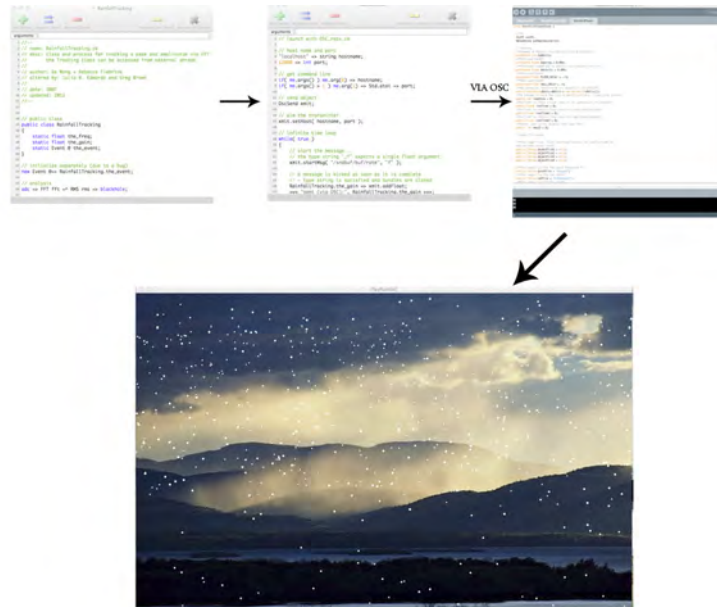

Developing a Method for DNA Sequence-based Rigidity Analysis

Emily Flynn

This summer, I extended KINARI-Web to perform rigidity analysis on nucleic acids and protein-nucleic acid complexes with known structures. KINARI-Web¹ is a freely available server for protein rigidity analysis developed by Professor Streinu's research group (Linkage Lab) at Smith College. Many structures in the Protein Data Bank (PDB), including viruses and ribosomes, were crystallized with both proteins and nucleic acids present. Previously, KINARI could only analyze the protein portion of the structure, but with the extension I developed, it can now identify the rigid and flexible regions in the entire complex. KINARI works by inputting a PDB file and then processes the file to identify of covalent and non-covalent interactions within the macromolecule. A mechanical model is created using these interactions, and rigidity analysis is run using the pebble game algorithm. The results of rigidity analysis can then be viewed in a Jmol based visualizer. In order to extend KINARI to analyze DNA and RNA, functionality was added to identify the structures present in a PDB file, and place covalent bonds accordingly. The procedures for identifying non-covalent interactions, specifically hydrogen bonds and hydrophobic interactions, were also adapted to recognize nucleic acids.

In addition, I began developing a method to analyze the rigidity of DNA molecules from sequence alone. There are a huge number of DNA sequences available (>135 million in GenBank), but relatively few DNA structures (<4,000 in the PDB). This new method will allow KINARI to determine the rigid and flexible regions of DNA molecules using only their sequence, which has many applications including the design of DNA nanostructures. Currently, KINARI uses the coordinates provided by X-ray crystallography data to identify non-covalent interactions. Our method for sequence-based rigidity analysis uses patterns seen in DNA molecules with known structures to place non-covalent interactions in DNA sequences without coordinates. In the future, we will focus on validating the DNA sequence-based rigidity analysis by comparing the rigidity analysis of DNA molecules with known structures to the analysis of their sequences.

In the fall, I will present a poster describing this summer's research at the ACM Bioinformatics, Computational Biology, and Biomedicine conference.² This project will also be continued throughout the academic year. (Supported by the Schultz Foundation)

Advisor: Ileana Streinu

References:

¹Fox, Naomi, Filip Jagodzinski, Yang Li, and Ileana Streinu. KINARI-Web: A Server for Protein Rigidity Analysis. *Nucleic Acids Research*. 2011. 39 (Web Server Issue): W177-83.

²Flynn, Emily, Filip Jagodzinski, and Ileana Streinu. Towards Sequence-Based DNA Flexibility Analysis. Poster to appear at: ACM BCB Conference; 2012 October 7-10th; Orlando, FL.

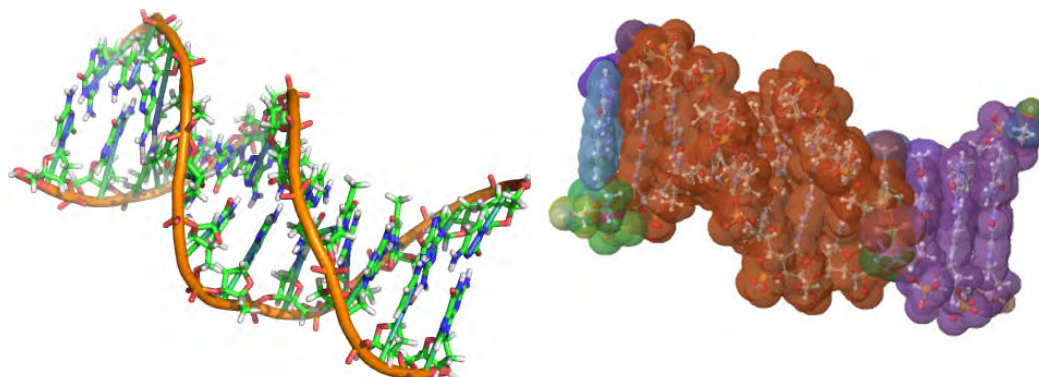
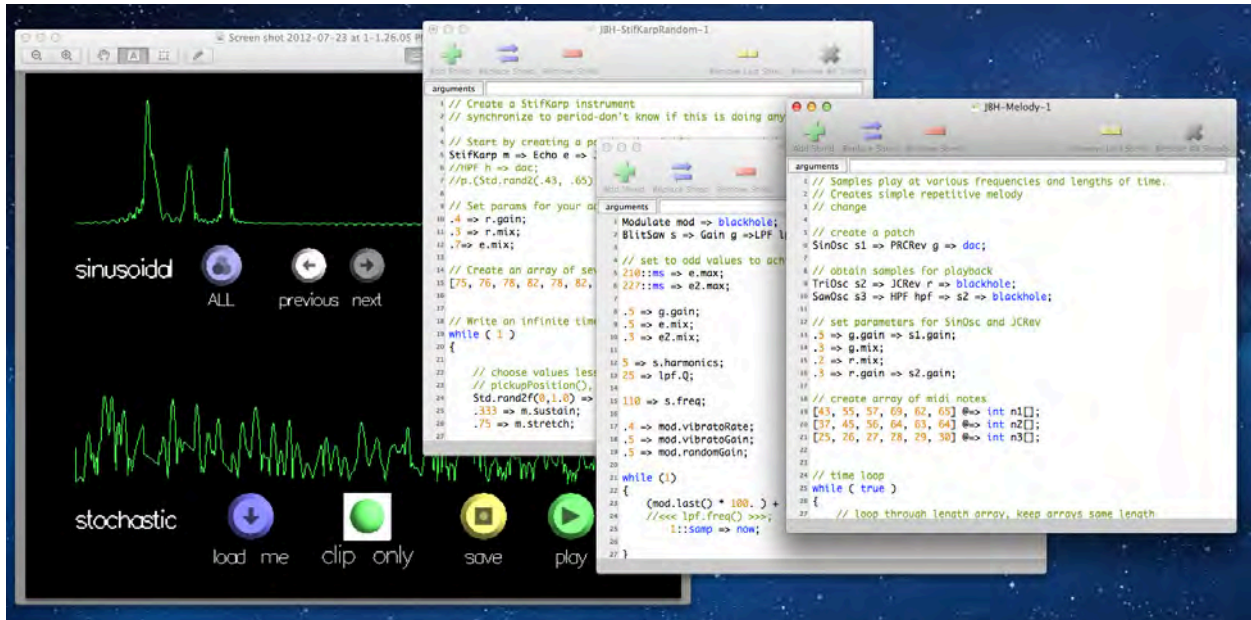

Figure 1. Cartoon rendering of a DNA 12-mer (PDB file 119D) and rigidity analysis of the same molecule. Colored bodies represent rigid clusters of atoms.

Programming Sound with Chuck and TAPESTREA

Janet Harris



How can sound teach computer programming? In my research of the literature on ways to achieve audio synthesis, I focused on two open source programs developed by graduate students at Princeton: ChuckK (2007, Ge Wang) and TAPESTREA (2009, Ananya Misra, Wang). ChuckK produces on-the-fly innovative digital audio synthesis and analysis and “live” programming techniques. TAPESTREA’s GUI interface displays several options for interactive audio analysis and synthesis and gives a unique visual.

ChuckK uses object-oriented programming principles and basic data type structures: classes, objects, variables and operators. A fully operational ChuckK program consists of two lines of code: a patch, and a time loop. The patch object defines a waveform using a provided library of oscillator classes, and complex sounds are created by chaining together unit generators, such as harmonics, echo or reverberation to a patch.

Using conditional statements, for loops and functions, I created rhythm and percussive effects with code that varied durations of playing frequencies to “now,” the time synchronizing keyword. ChuckK system-provided filters extract specific bandwidths of sound to change pitch, add vibrato as well as apply random generators for unique and varying patterns. Built-in ChuckK analysis tools, such as FFT and RMS, were customized to calculate the location of beats within a file. Beats per minute provides information to identify musical genres, change tempo or development of rhythmic interaction with touch devices.

TAPESTREA provides a visual landscape for manipulating, separating and analyzing graphical displays of the sounds. The separation button distinguishes stable core frequencies from ambient noise. Each extracted frequency is saved as a waveform. The waveform templates are then used for further synthesis and reuse. This technique supports granular synthesis and transformation. Synthesized waveforms dragged to the timeline create transformed soundscapes using in gaming, video production, nature soundscapes or musical production. Using these programs offers a promising pedagogical approach to teaching programming and digital synthesis, because they engage both auditory and visual senses to facilitate deeper learning. (Supported by the National Science Foundation)

Advisor: Judy Franklin

The Alignment of Two Partially Overlapping Point Clouds

Shannon MacKenzie

One way for a computer to “see” is through a point cloud, or a map of a space’s surfaces represented as points in a 3d coordinate system. Should two cameras be pointed at the same object from different angles, their coordinate systems will be different, as they are each facing the object from a different location. Aligning point clouds is a process in which the two coordinate systems are moved and rotated to form a single coherent 3-D mapping. This is particularly useful when mapping a room or area of which one camera cannot see its entirety. Two cameras that can see the same room from different angles will still have parts that overlap, and can align their coordinate systems based on these areas.

This project worked to create a program that automatically aligned two point clouds with various overlaps. In order to begin aligning the clouds, we referred to various papers on the algorithms used to align point clouds. The program was able to change algorithm parameters and the shape of the point clouds to vary how it was solved. Various point clouds, including one initial alignment, are shown in the pictures attached.

Though alignment of exact matches in point clouds (every point in cloud A had an exact match in cloud B) was good, and rarely failed, the program’s running time rose exponentially with the number of points in the cloud. This became problematic as we wanted to use a real-world point cloud generated by the Kinect as opposed to synthetic point clouds use for testing. The Kinect generates large and heavily detailed clouds, which meant that the program ran for over an hour trying to align even a tenth of the Kinect’s points.

The biggest challenge this research faces in the future is aligning clouds quickly and efficiently. Though computers are easily able to align smaller clouds, even with an inefficient algorithm, larger clouds need to be aligned in order to simulate a genuine 3-D space. Areas in which this could be used include tracking people within a certain space and a more accurate location-aware device. People may be tracked in order to create a more interactive space. Also, GPS data on smart phones is currently non-specific and unreliable. Being able to align point clouds generated by the phone’s camera with point clouds generated from GIS data would help to accurately locate the phones position. (Supported by Smith College Summer Research Fellows Program (SURF))

Advisor: Eitan Mendelowitz

References:

- ¹D. Chetverikov, D. Stepanov, P Krsek. 2005. Robust Euclidean Alignment of 3D Point Sets: The Trimmed Iterative Closest Point Algorithm. *Image and Vision Computing*, 23: 299-309.
- ²E. Lomonosov, D. Chetverikov, A. Ekárt. 2006. Pre-registration of Arbitrarily Oriented 3D Surfaces Using a Genetic Algorithm. *Pattern Recognition Letters*, 27(11): 1201-1208.
- ³P. Besl, N. McKay. 1992. A Method for Registration of 3D Shapes. *IEEE Trans. Pattern Analysis and Machine Intelligence*. 14: 239-256.

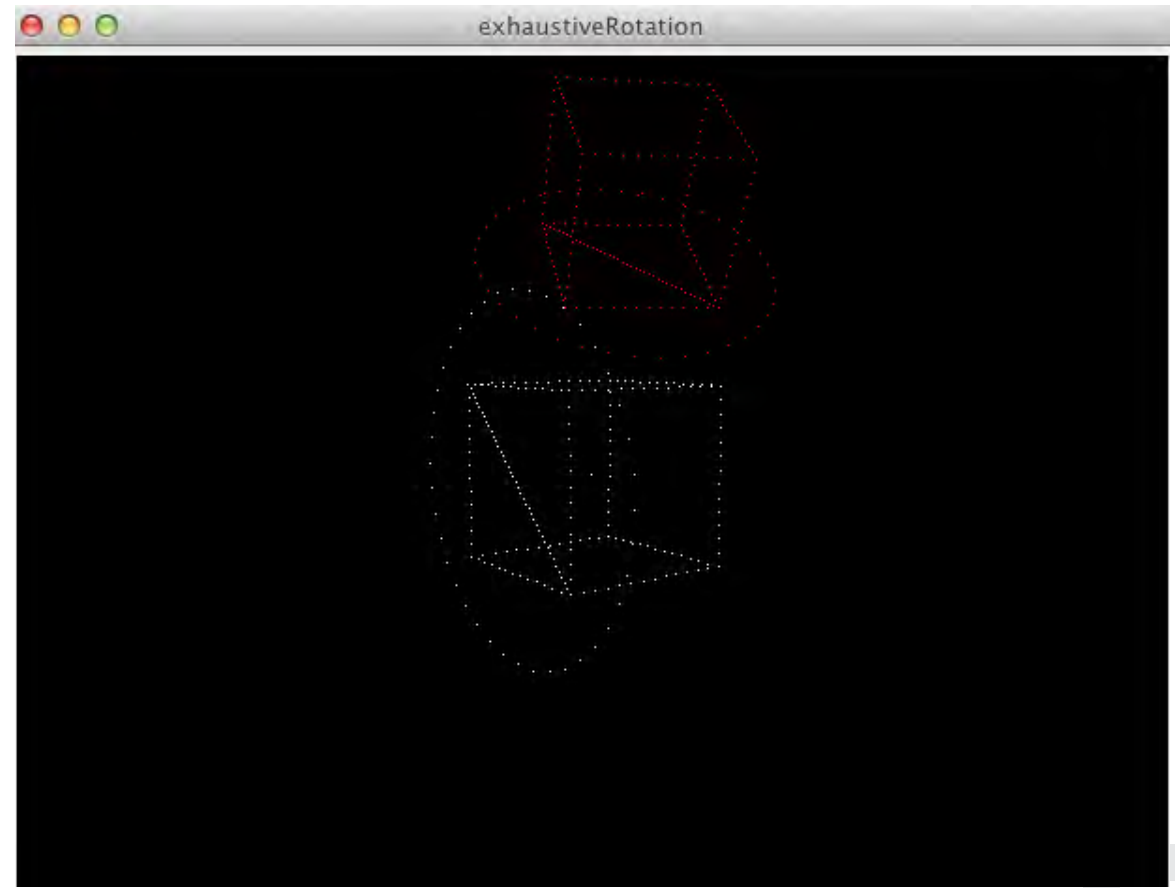
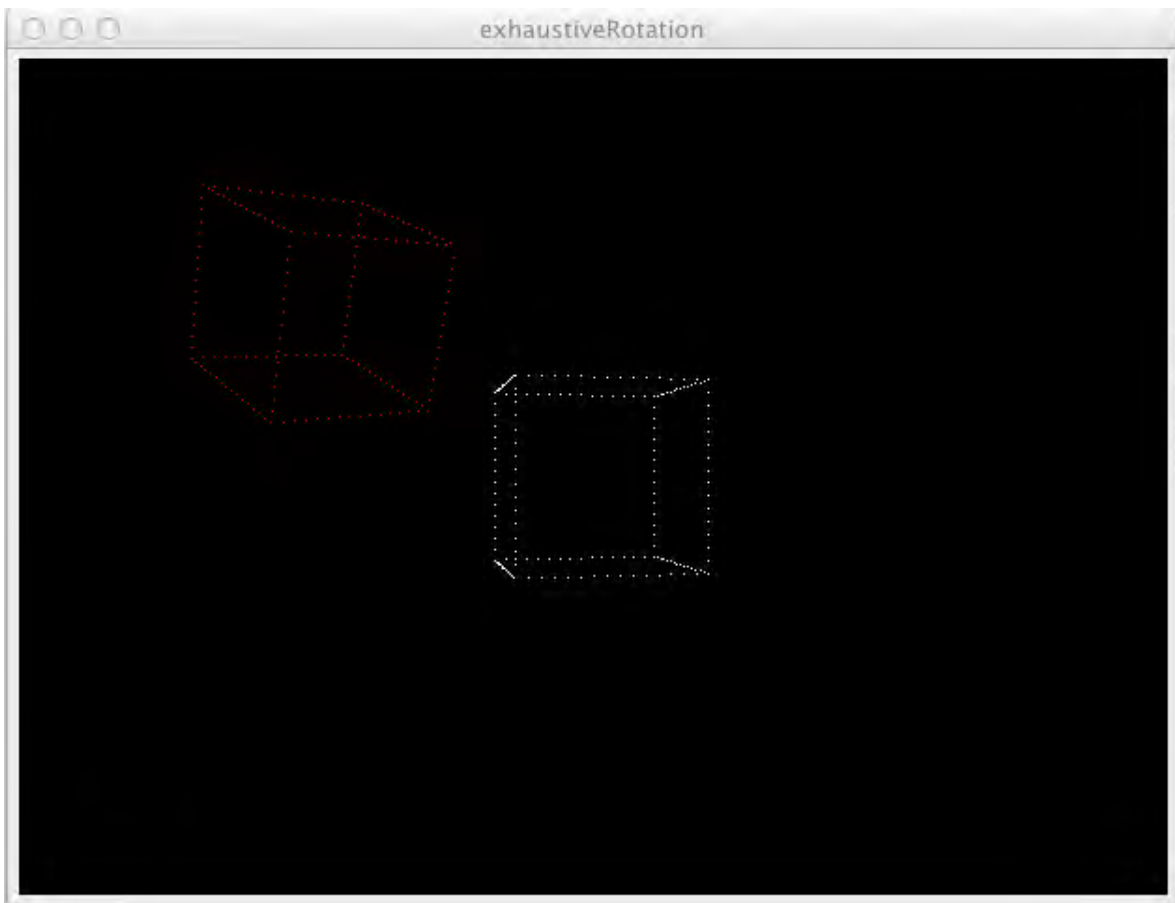

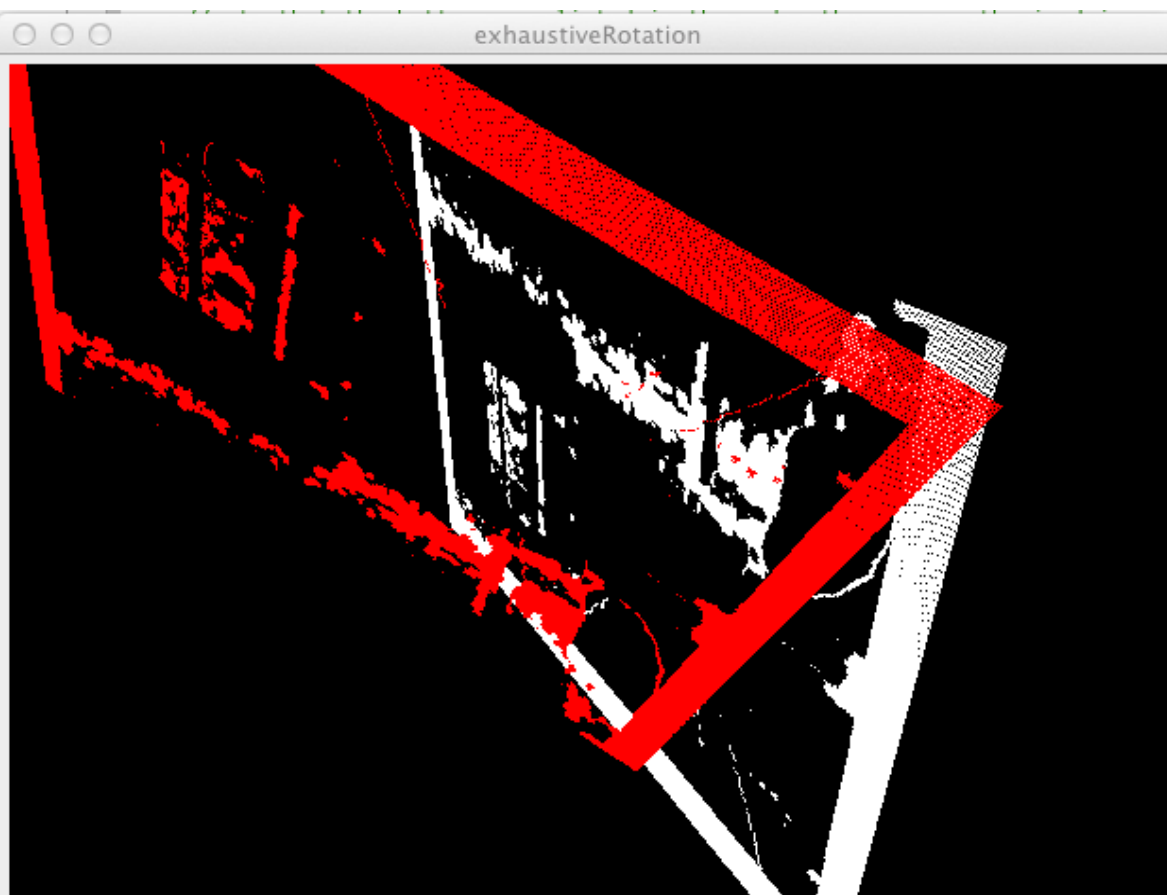
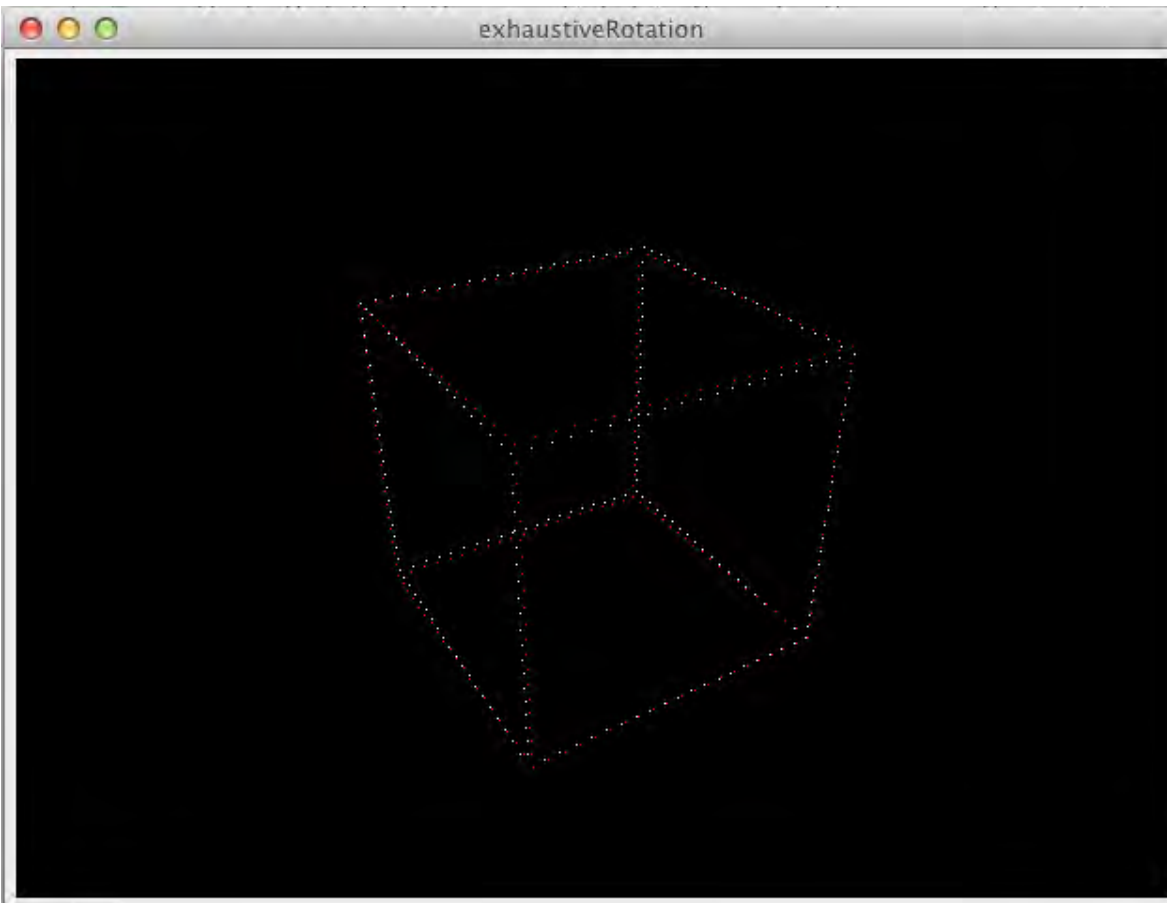

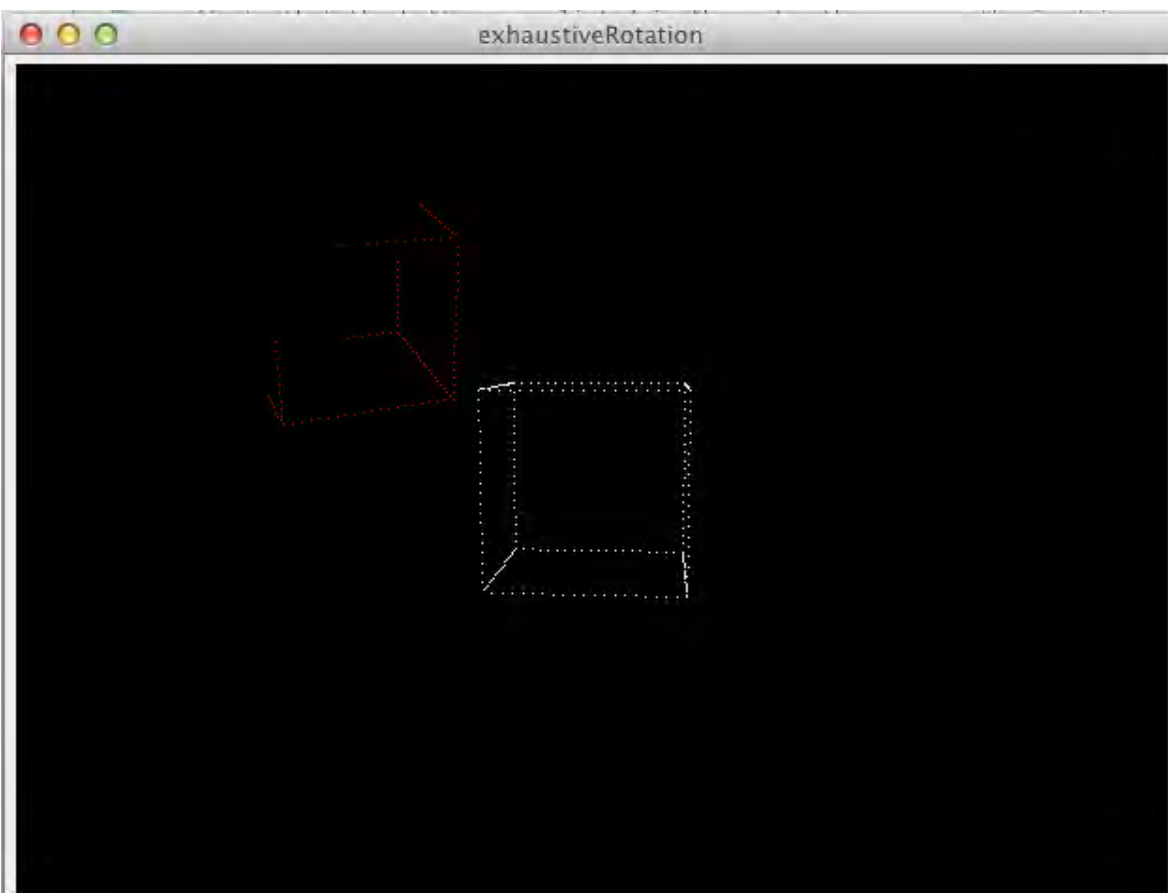

Making the Keyboard Instrument

Freda Moore

As part of my research this summer, I worked mainly on the keyboard instrument (KIns) project. The goal of the project was to create a viable musical instrument that was free, open-source, simple, able to run on any computer that can run ChucK, and aimed at a user base that did not otherwise have access to physical musical instruments or formal music instruction. Throughout its development process, the KIns has provided an interesting look into the difficulties and quirks of making a computer/human music generating environment.

ChucK, the language that the KIns is written in, is a strongly-timed, concurrent, and on-the-fly audio programming language, created by Ge Wang and Perry Cook. I wanted to use ChucK to create music, rather than just sounds, and after some experimentation, I decided that the best way to do this would be to create a program that could be used to naturally create music.

The KIns went through a couple iterations before reaching its current, semi-finished state. It began as a simple program that mapped sounds to keys on the keyboard, and had only one type of sound. My coworker, Lucy Chikwetu, and I worked together to create an interface and a wider array of sounds for the KIns. I then worked to create a “looping” feature, in which the user could record a short sequence of keypresses which the KIns would record and then play back in a loop. This is a technique used by musicians in live performances (for example, in this video: http://www.youtube.com/watch?v=n2DHHRyt_Bw).

The KIns as a whole was quite a large undertaking, and I did not manage to implement all the features that I wanted. However, because of the intended open-source nature and the code that I was careful to fully document, it is my hope that others can add onto the KIns in the future, whether for fun or for learning purposes. (Supported by the National Science Foundation)

Advisor: Judy Franklin



Handwriting Recognition in Classical Syriac

Cordelia Nowak

Much of human history and literature is preserved only in handwritten texts; these texts date back thousands of years and are written in languages which few or no modern people understand. Collecting knowledge in easily accessible databases which can be studied at researchers' leisure is vastly important for academics in many different fields of the humanities. There is a wealth of information and literature in libraries written in Classical Syriac, an ancient dialect of Middle Arameic. Handwriting recognition is a difficult endeavor for a computer scientist: what a human mind can do in a second is enormously difficult for a computer. Programs built to recognize handwriting must be able to accommodate for human error and a thousand variations in size and style from writer to writer and even within the same text.

Our goal in this project was to get the program to be able to recognize individual characters from a Syriac document. In order for the program to understand a handwritten word, it was necessary to use a classifier which would determine whether or not a letter is in a particular word. The classifier which we chose is a Support Vector Machine which, when given positive and negative examples of a certain letter, can be trained to identify whether or not there is a patch on the word which is a positive match for the letter in question. By going through the alphabet and performing the test to identify whether or not the letter is in the word, the program can eventually recreate the word and store it as a digital book.

Our work utilized scans from a Classical Syriac book of Genesis. Initially, when provided with a correct transcript of a section of the book of Genesis containing roughly 1800 words, the program was able to superimpose and alter to fit a model (known as a PSM or Part Structured Model) onto the text. The PSM is a general model for what a letter should look like composed of nodes bound together by stretchable pointers so that the model can accurately fit over a letter. Once the program reached this level of functionality, it became necessary to train the program to work without a transcript provided. At this point we trained an SVM for every letter of the twenty-two in the Syriac alphabet. For each letter, we compiled a list of instances of that letter which were labeled as positive examples and a list of all the other possible letters which were labeled as negative examples. Once training was complete, the SVM was able to accurately predict what a letter was a large portion of the time, although some letters are still more reliably accurate than other. Most are well over 90% accurate.

Although the project is by no means finished, we now have the correctly formatted data necessary to classify the characters and we have a Support Vector Machine that is quite capable of forming the backbone of the program. This is a big improvement where we had very little done with the text other than some manually completed transcripts and a file breaking the text into lines and words. With relatively little work, we can soon have a fully functioning program capable of reliably recognizing Syriac text. This program is well on its way towards being a serious asset for Syriac scholars. (Supported by the Schultz Foundation)

Adviser: Nicolas Howe

Locative Media Development on Android

Weini Yu



Locative media, also known as location-based media, on mobile devices with Real-time locating system technologies can deliver media content to the user based on his/her location. When the user enters the selected area, with the device's GPS, Wi-Fi or mobile network on, he/she can get media content from the device or an external server which often provides more in-depth information about the current location.

My project is based on Android using Java. I created an application which includes two activity classes, one service class and one broadcast receiver class. When the application is launched, the user can see where he/she is on the map by clicking the "Locate" button. The map is interactive so the user can also move the map around and pinch to zoom. The map view is created using Google Maps API. The specific geographic coordinates are also shown above the map. When the toggle button "Tracking" is on, the TrackerService bound to the activity will be turned on in the background, which can notify the user when getting into certain areas even when the current activity is not visible to the user. By clicking the "Camera" button, the user will be taken to the system's camera interface where he/she can take a picture or a video. Once it's done the picture or video will be saved into a folder specifically created by this application on the external storage and the preview will be shown. The user can then choose to "Save This Location" which creates a proximity alert in the service using the geocoordinates stored in this photo's EXIF. If so, when the user gets close to the point of interest, in this case the location where the picture is taken, he/she will be notified.

This project involves android core classes, libraries and concepts such as activity, intent, service, broadcast, toast, notification, Google Maps API, location manager, binder, basic layouts, and passing data to and from activities. I better understand Real-time locating system technologies on Android, creating Android application and Android OS in general through this project. (Supported by the Schultz Foundation)

Advisor: Eitan Mendelowitz

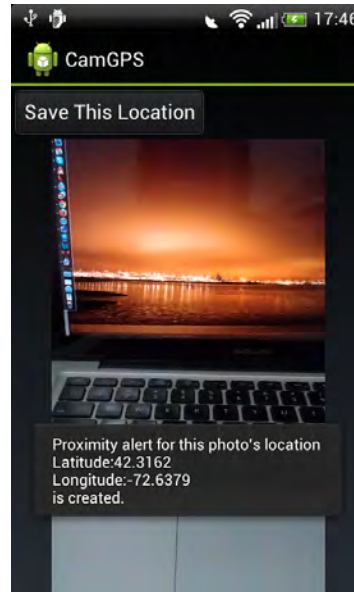
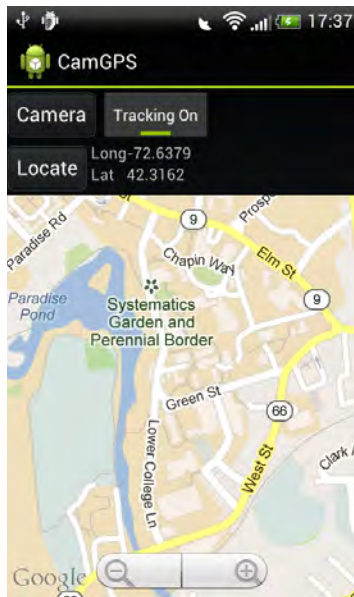

Analyzing Inter-subject and Intra-subject Variability in Energy Power Reflectance

Defne Abur

Energy power reflectance is the squared magnitude of the reflectance in the ear, the ratio between the reflected pressure wave and the incident pressure wave (if all pressure absorbed it is 0, and if all pressure is reflected it is 1.) This summer, I took biweekly measurements of energy power reflectance in the ear, at three different positions in the ear canal, in five different subjects. Using this data, and data previously collected in four subjects during the past academic year, my goal was to work on analyzing how the measurements may vary between subjects and in one subject's ear over time, specifically looking at how the data is affected by the measurement location.

All subjects were examined to ensure a normal ear canal and ear drum and demonstrated normal hearing in an audiogram test. During each biweekly session, subjects underwent tympanometry in both ears; the tympanometer ensures that the static air pressure in the middle ear is near zero. Then, the energy power reflectance was measured using the FDA approved HearID system from Mimosa Acoustics (version 4.0)¹ with an Etymotic ER-10c sound delivery system and foam tips. The measurements were made at three positions: 3mm deeper than the entrance to the ear canal, at the ear canal, and 3mm out from the entrance to the ear canal. The foam tip was marked at these distances with an electronic caliper for accuracy (Fig.1).

The measurement data was loaded into programs I edited to plot and compare subject data in MATLAB. The programs plotted graphs of each session for every subject, color coordinated by position. I then created a database to store all data with twelve variables that create variability in the measurements.

In order to use this database to analyze my measurements, I had to figure out what statistical analysis method was most appropriate. I read a thesis written by Mariel Finucane² where she explains that "Longitudinal studies are helpful in understanding how subtle associations between factors of interest change over time", so I continued to read about the method of longitudinal data analysis. I read specific case studies in 'Longitudinal data analysis'³ and 'Analysis of Longitudinal Data'.⁴ I will begin using longitudinal data analysis on collected measurements and continue working on my project in the following academic year. (Supported by the Four College Biomath Consortium and the National Science Foundation)

Advisor: Susan Voss

References:

¹ Mimosa Acoustics' HearID™ Auditory Diagnostic System (Version 4.0). Software. (2006)

² Finucane, Mariel. "Translational methods in biostatistics: linear mixed effect regression models of alcohol consumption and HIV disease progression over time." Thesis. Smith College, 2004. Print.

³ Fitzmaurice, Garrett. Longitudinal Data Analysis. 2nd. 2011. Print.

⁴ Diggle, Peter. Analysis of Longitudinal Data. 2nd. 2002. Print.



Figure 1: ER-10C probe marked for different positions using electronic caliper

Designing Learning Environments for K-12 Engineering Education

Wiame El Bouhali

Why do skyscrapers stand? What is a tornado-proof home? How does engineering relate to my world? These are some of the questions that I worked on answering this summer. Engineering is everywhere around us and yet, this fascinating field remains frightening to a lot of people. Through the use of an educational website,¹ the *Talk to me* team has been working on introducing engineering to middle school students in order to improve their technological literacy. The website consists of a young adults' novel, online activities that expand on concepts introduced in the novel and a blog written by students describing their lives as Smithies taking engineering courses.

Using the idea of Imaginative Education (IE) developed by Kieran Egan, the activities developed challenge the students to go beyond the usual basic classroom requirements; students are encouraged to dig deeper, look further, work in groups, and discover truths. Through the activities developed, we are helping middle school students get a deep understand of some of the grand ideas of our time, such as Artificial Intelligence (AI) and sustainability. Through introducing them to engineering at a young age, we aim to improve their attitude towards the engineering profession, and have them consider it as a possible career for the future.

I have been involved this summer in implementing a downloadable illustrated curriculum guide to support middle school teachers using our website. This teacher's guide includes background information about IE and the engineering concepts on the website, as well as step by step instructions for the different concepts.

During the summer, I also started working on introducing the concept of structure. This year, through Special Studies, I will continue implementing this interactive activity that uses extremes of reality such as tornadoes and earthquakes, to draw students' attention and have them thinking about how buildings stand and how we can improve the design of our current homes to make them safer. Research has shown that students at this targeted age are fascinated by extremes of reality; one of the main ideas of Imaginative Education. This technique has children personally involved in their learning experience, pushing them to learn more and work together to solve daily problems. (Supported by the Schultz Foundation)



Fig 1: Screenshot of the Talk to me website. www.talk2mebook.com

Advisor: Glenn Ellis

References:

¹www.Talk2mebook.com

Summer with CEEDS

Elizabeth Esposito

.....

Over the course of the summer of 2012, while interning for Reid Bertone-Johnson, I conducted research and design projects, as well as completing many other tasks. Individually, I researched the components of an American Chestnut Seed Orchard, so that one could be installed at the Ada & Archibald MacLeish Field Station. I focused on layout, integration with the Field Station, irrigation, and solar electric fencing. I visited other orchards and accrued information under the guidance of Professor Paul Wetzel. With his help, I was able to fully understand the history and possible future of the American Chestnut. In order to receive funding from the American Chestnut Foundation to complete this project, I created a list of materials and prices, as well as a layout of the orchard. I completed my layout using AutoCAD. Under the direction of Susan Froehlich, I researched the materials necessary to create an electric fence around the site, which would incorporate a design by an engineering student. Through this project, I became aware of different aspects of the design process.

With the other interns, I collected GIS data about Ward Three in Northampton to be used in future research efforts. Using InDesign, we created two primers of previous student work that used areas of Northampton as design opportunities. The primers were presented to town leaders. For this endeavor we learned how to design and format the pages in the primer to best communicate the designs. In the final weeks, we were teaching assistants at the Field Studies for Sustainable Futures camp, a branch of the Summer at Smith program for high school girls. The group work helped us to master group dynamics and time management skills. (Supported by the Smith College Botanic Garden Landscape Studies Fund)

Advisors: Reid Bertone-Johnson, Marcia McNally, Paul Wetzel and Susan Froehlich



A seed orchard I visited.

Rural Electrification in South Africa: A Preliminary Study

Jennifer Holliday

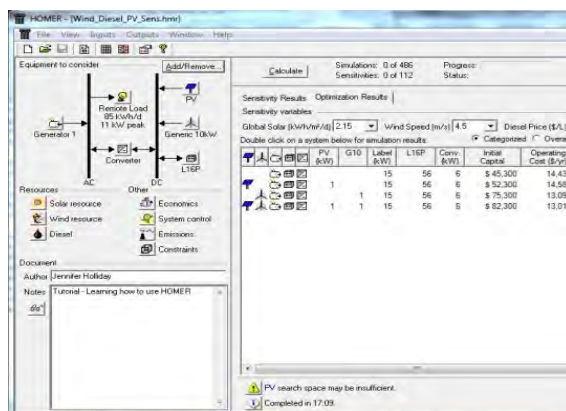

Rural households, especially in developing countries, typically use a mixture of fuels, such as candles, wood, kerosene, and batteries, to provide energy for cooking, heating, and lighting. Replacing some or all of those fuels with electricity has numerous benefits including cleaner air in the home; reduced time spent gathering firewood; and better lighting during the evening hours allowing children to focus on schoolwork.¹ The conventional approach to rural electrification is to extend the national electricity grid, an approach that has a high per capita cost when the low population density and low demand for electricity in rural areas is considered.²

Before 1990, less than a third of South Africa's population was electrified; a rapid electrification programme meant that by the end of that decade that proportion had doubled.³ However, most of the electrification took place in urban areas, leaving many people in rural areas with no electricity. My research this summer looked into the possibility of using small off-grid renewable energy installations to provide electricity in rural areas, taking into account whether the technologies were suitably mature and how governmental policy should be involved.

My main approach was a comprehensive survey of the research literature looking at electrification in general and case studies of electrification projects in order to determine whether using renewable off-grid systems was a feasible option. A secondary approach consisted of learning how to use HOMER, an optimization software developed by the NREL, which allows me to simulate various off-grid options. Using inputs of solar resource data, load profiles, and different unit sizes for system components, the software allows me to compare different systems in terms of the initial capital required and the cost of generating 1kwh of electricity.

My research was intended to be a preliminary study into the topic of rural electrification such that I could determine the feasibility of doing a senior thesis on the topic, which I will now be undertaking for the 2012-13 academic year. (Supported by the Schultz Foundation)

Advisor: Judith Cardell

References:

- ¹Zahnd, A. and Kimber, H.M., 2009. Benefits from a renewable energy village electrification system. *Renewable Energy*, 34(2): 362-368.
- ²Mahapatra, S. and Dasappa, S., 2012. Rural electrification: Optimising the choice between decentralised renewable energy sources and grid extension. *Energy for Sustainable Development*, 16(2): 146-154.
- ³Bekker, B., Eberhard, A., Gaunt, T. and marquard, A., 2008. South Africa's rapid electrification programme: Policy, institutional, planning, financing and technical innovations. *Energy Policy*, 36(8): 3125-3137.

Renewable Energy and its Impacts on the Environment and Economic Development in Central China

Adrienne Horne

Grid integration of renewable energy is essential to China's economic growth and environmental health. The combination of a rapidly increasing population, substantial economic growth, and steady urbanization has contributed to China's astounding energy consumption growth rate of 9.4% and a 3.5% average annual rate of increased electricity consumption.^{1,2} Coal and oil remain the major sources of energy in China, which means that at this rate of increased energy consumption greenhouse gas emissions will only continue to rise unless there is a dramatic change in energy usage.³ An integration of and gradual transition to renewable energy sources would curb greenhouse gas emissions while meeting China's growing energy needs. However, China has many diverse regions, each with different energy needs and resources. It is necessary to consider characteristics of each region when determining the optimal plan to meet energy needs. Once a proper energy plan has been created for each region, modeling each regional system in PowerWorld will make it possible to adjust each plan and visualize where and how integration of each new system will optimize energy output, economic benefits, and environmental sustainability.

We used the tutorials in "Power System Analysis and Design" by J. Duncan Glover and Mulukutla S. Sarma to acquire the skills to use PowerWorld, in order model and analyze systems more easily in the future. Articles pertaining to separate renewable energy resources and energy demands by region in China were found using sciencedirect.com and used to create a bank of knowledge in order to better determine which new energy sources will optimize increased energy production in each region.

We found that it may be most effective to provide a sustainable energy production plan to quickly developing rural regions before integrating renewable into the existing urban grid or bringing electricity to other rural communities. Although urbanization has led to redistribution of population and increased energy consumption, the majority of increased energy consumption is projected to occur in the developing rural areas of Central China where commercialized energy is becoming more accessible.⁴ We chose to focus on Central China since that region contains the quickly developing province of Anhui and is predicted to require the most energy by 2020.⁵ Regardless of the optimal renewable energy source for this region, integration of this new source will be met with many challenges. Since renewable energy such as solar and wind power are variable sources, it will be necessary to increase the flexibility of the regional generation portfolio.⁶ This can be accomplished through balancing of the generation portfolio, controlling the system load, and improving methods of energy storage.

In order for a successful integration into the existing electrical grid, it is necessary that renewable sources be accounted for early in system planning and included with traditional sources in the overall system load. First, more research must be completed to determine the optimal combination of energy resources to meet unique regional energy demands. After determining appropriate regional needs, it will be possible to model regional systems in PowerWorld, accounting for increased need of flexibility. According to model results, it will be necessary to adjust percentages of energy supplied by each source in order to remain efficient and achieve the desired economic and environmental stability. (Supported by the Schultz Foundation)

Advisor: Judith Cardell

References:

¹ Komiya, Ryoichi. Asia energy outlook to 2030: Impacts of energy outlook in China and India on the world. The Institute of Energy Economics, Japan (IEEJ) EDMC.

² Linwei Ma, Pei Liu, Feng Fu, Zheng Li, Weidou Ni. 2010. Integrated energy strategy for the sustainable development of China. State Key Laboratory of Power Systems, Department of Thermal Engineering, TsinghuaBP Clean Energy Center, Tsinghua University.

³ 2010. China: Country Analysis Brief. EIA, International Energy Statistics.

⁴ AiaoMei Liang, Ying Fan, YiMing Wei. 2006. Multiregional inputoutput model for regional energy requirements and CO2 emissions in China. Institute of Policy and Management (IPM), Graduate University, Center of Forecasting Sciences, Chinese Academy of Sciences.

⁵ Ibid.

⁶ Bebic, J. 2008. Power System Planning: Emerging Practices Suitable for Evaluating the Impact of High Penetration Photovoltaics. GE Global Research Niskayuna, New York.

⁷ Ibid.

The Influence of MP3 Headphone on Human Ears

Huimin Ji

.....

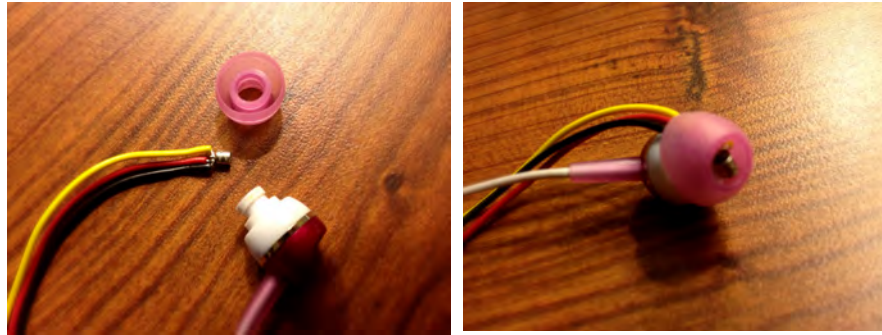

The popular usage of MP3 headphone potentially causing damage to ears has long been an issue. Especially when trying to drown out the outside noises, people turn up the volume of the headphone to high levels that in long term, could cause permanent damage to hearing. This project uses a system run by microcontroller, A-D converter and an SD memory storage card, which has been designed to record sound with a microphone and write the voltage response to the memory card, to collect, store and analyze the sound pressure output. This is a long-term project, and I focused on improving the prototype's data collection speed and applying a microphone on a regular MP3 headphone for this summer.

The prototype uses a Parallax microcontroller with Spin language as an algorithm. There is a protraction of time in writing the collected data into the SD card. For the prototype, it needs about 6s to write a series of 0.4s continuous data on the card. I focused on two parts to improve the writing speed: the SD card interface and the algorithm.

There are three different logics for SD card application: SPI bus, 1-bit bus and 4-bit bus. The SPI bus mode is using two pins for data input and output respectively. The 1-bit bus mode is using one pin for both data input and output, and 4-bit bus mode is using four pins for both data input and output simultaneously. For current SD card interface, the fastest logic is the 4-bit bus mode, but the system of using this logic requires licensure so it is not applicable to this project. Using SPI bus mode for SD card, as in the prototype, is the optimized methods.

To improve the writing speed by changing the code, I first revised it based on Spin language. The prototype uses a script package with one main file and a sub-file. The sub-file is applied to general memory cards' reading and writing, so it starts by identifying the memory card type between SD, HCSD, and MMS card every time it runs, which takes up extra time. I cut off the redundant codes for the identification process, and limit the package to a high capacity SD (HCSD) card that is used in this project. Trimming the code did not make the writing speed fast enough, and the data collected within 0.4s can now be written into SD card in 3 seconds.

Another optimizing method to accelerate the writing process is to convert parts of the script into Assembly language. Assembly language is a machine language, which runs a lot faster than Spin language. The converted part is in the main file of the SD card writing script package where the function is directly called in the integrated script. I have not finished this process yet, and it should be continued in the coming academic year research.

Other than improving the prototype, I also applied a microphone to a regular MP3 headphone (as shown in photo above), in order to apply the developed prototype to MP3 music output measurements. (Supported by the Schultz Foundation)

Advisor: Susan E. Voss

The Framework of Wind Energy Paired with Demand Response

Jinjin Lu

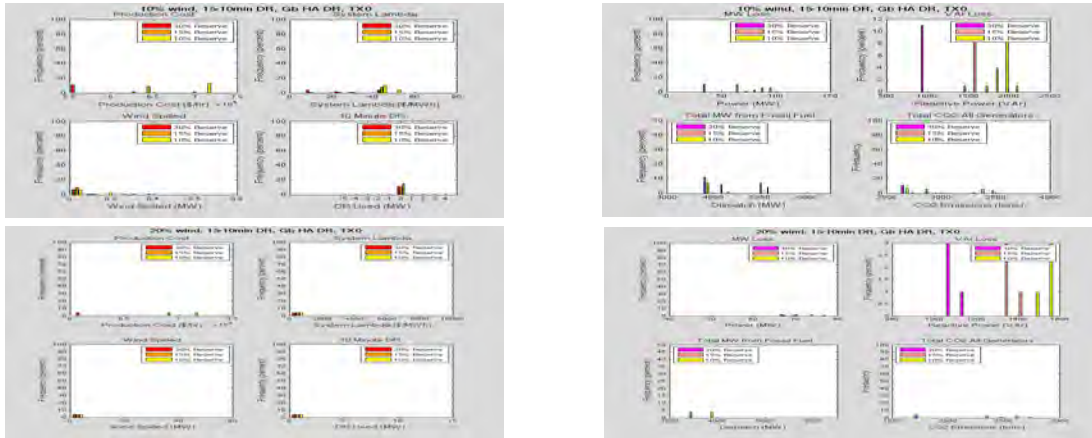

The wind speed varies in time and space. The uncertainty and variability of wind resources require the power system to ramp up or down other resources to mitigate the difference between the real wind power and the forecasted output. A responsive demand method can be used to alleviate the forecasting error from the wind output variations.¹ AC OPF was used to determine the forecast dispatch of wind output, and the Monte Carlo simulation to gather the forecast errors of wind distribution.² The framework used the 39-bus IEEE test system. I used the codes in MATLAB originally created by Professor Cardell to create a base case in wind, a batch file that generates .csv file, a .fnc.txt file to be called in making plots, and a makeplots file. In wind base file, the constraints of transmission line and the percentage of demand response need to be specified in each test case; the cost curve for load need to be in correspondence with the LoadCostTab file being open in MATLAB. Scenario one has 10% wind penetration, meaning three wind farms were employed into the power system. With various outputs in each wind farm, demand response and transmission constraints didn't make a difference in each case. Scenario two has an increased wind penetration up to 20%. Without transmission constraints and demand response, the increase of wind penetration level reduces power loss, fossil fuel consumption, and CO₂ emission. With 20% wind penetration, the integration of demand response as well as transmission constraints made no difference in the system. (Supported by the Schultz Foundation)

Advisor: Judith Cardell

References:

- ¹J.Cardell and C. Anderson, "A Decision Framework for Optimal Pairing of Wind and Demand Response Resources", 2010.
- ²J.Cardell and C. Anderson, "The Impact of Wind Energy on Generator Dispatch Profiles and Carbon Dioxide Production", 2012.

Wind-Diesel Microgrid System for Remote Villages in Kenya

June Lukuyu

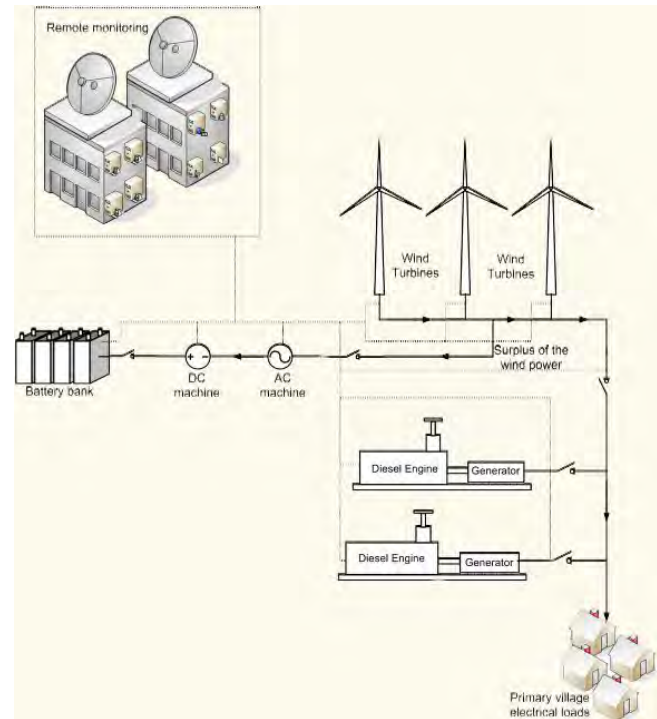

Electricity has proven to be a major contributor of global socioeconomic development. It is the foundation for urbanization and industrialization, which results in a higher standard of living for the people who have access to electricity. Electricity has been confined to urban areas and for this reason several countries, especially less developed ones are lagging behind in terms of socioeconomic development. Kenya, like most countries in Sub-Saharan Africa, is faced with the problem of limited electricity access especially in rural areas. To address this issue, my research proposed the use of wind-diesel microgrid systems to achieve rural electrification.

A microgrid is a small-scale power supply network that is designed to provide energy for a small community. As used in this project, a wind-diesel microgrid system combines diesel generators and wind turbines alongside additional equipment such as batteries, power converters and various control systems to generate electricity. A remote village in Northern Kenya, Marsabit, which is currently being served by an off grid wind-diesel system was used as a case study. A power flow model of the hypothetical Marsabit wind-diesel generation, transmission and distribution network was developed to simulate and analyze the reliability of the system. The percentage of wind capacity and diesel energy going into the system to serve the 17 % annual increase in demand for electricity in Marsabit town over a period of eight years was examined as an indicator of system reliability. Using the power flow model, system reliability for different scenarios based on different sizes of diesel generators and different wind capacity were analyzed.

Results from the comparison of the different scenarios showed that the wind-diesel microgrid system tends to be more reliable if the diesel generator capacity is increased as opposed to wind capacity during power system expansion to meet the growing demand. This is owing to the fact that wind power tends to have a low capacity factor and has an intermittent nature. Nonetheless, these technical issues can be dealt with through grid control but this consequently increases the cost.

The findings of this research will be presented at the annual North American Power Symposium at the University of Illinois, Urbana-Champaign, in September 2012. (Supported by the Schultz Foundation)

Advisor: Judith Cardell

References:

¹H. Ibrahim, R. Younès, T. Basbous, A. Ilinca, M. Dimitrova, Optimization of diesel engine performances for a hybrid wind–diesel system with compressed air energy storage, *Energy*, May 2011. Vol 36, Issue 5, Pg 3079-3091

Otoacoustic Measurements on Patients with Idiopathic Intracranial Hypertension before and after Lumbar Puncture

Mary McGrath and Alina Pechacek

Astronauts have returned from long missions at the International Space Station having shown signs of elevated intracranial pressure (ICP). Distortion product otoacoustic emissions (DPOAEs) are known to change systematically with ICP.¹ The goal of this study is to map known ICP to DPOAE so that DPOAEs may be used in future space missions to assess the ICP of astronauts.

This study compares the DPOAE, reflectance, and impedance measurements of subjects before and after the draining of cerebral spinal fluid (CSF) during a lumbar puncture (LP). The main populations studied were patients with idiopathic intracranial hypertension (IIH), a condition that results in increased global ICP due to imbalanced in and out flows of CSF, which is relieved by draining the CSF during an LP. This study has two sets of measurements on each subject, for each of which the ICP of the subject is known. Subjects were limited to ages between eighteen and 65. IIH patients were referred to St. Luke's Episcopal Hospital from local neurologists for an LP. Control subjects were recruited from St. Luke's Episcopal Hospital's in-patients needing an LP for diagnostics.

The LP begins with the subjects either sitting up or lying on their side with their back in a convex position. Once the needle is in place, the subject is asked to lie on their side with legs extended and head in line with the spine to ensure accurate pressure readings. After the opening pressure has been read, the middle ear pressure (MEP) is taken using a tympanometer. An ER10C probe with a foam tip is then inserted into the ear and given time to expand before starting reflectance and DPOAE measurements using the Mimosa HearID system. The CSF is then drained and the closing pressure is read. Finally the middle ear pressure, reflectance and DPOAE measurements are repeated.

The collection of data for this study is still in progress, as only a portion of the total number of subjects for the study as stated in the IRB were able to be recruited during our 8 week, direct involvement in the study. A significant portion of time was spent training doctors and a research nurse how to properly use the equipment to continue taking measurements after our departure to complete the study.

The preliminary data shows some of the expected changes in DPOAE magnitude and phase associated with a known change in ICP. (Supported by the National Science Foundation)

Advisor: Susan Voss

References:

- ¹ Marchbanks, R. J. and Reid, A. (1990). Cochlear and cerebrospinal fluid pressure: Their inter-relationship and control mechanism. *Int. J. Audiol.*, 24, 179-187.

Developing and Evaluating a Monthly Curve Number Method for Predicting Stormflow

Kate Meyer and Julia Signell

When rain falls on any surface, some is caught by the tree canopy, some infiltrates into the soil, and some runs off overland. The portion that flows overland reaches the stream shortly after hitting the ground, so this water is called stormflow. Predicting stormflow is an essential tool for addressing hydrologic problems such as flood forecasting, sedimentation, and nutrient loading. Over the past few decades the Natural Resources Conservation Service's Curve Number method has become one of the most widely used tools for predicting stormflow. This method uses antecedent wetness conditions, soil type, and land use information to assign Curve Numbers (CN) to watersheds. With a simple equation, CN and daily precipitation data can predict stormflow.¹

The simplicity of this method is appealing, unfortunately the CN method was designed for a daily time step and sometimes precipitation data are only available by month. Using the assumption that the depth of rainfall behaves exponentially, we modified the CN method to allow for monthly precipitation data. With this adaptation, the user can predict stormflow for a basin knowing only total monthly precipitation, CN, and the number of storms each month.

We evaluated this tool by comparing the measured stormflow ('observed stormflow') to three different predicted stormflows. We calculated one of the predicted stormflows by assuming that all of the storms in any given month had the same depth of precipitation ('simulated monthly mean'). We calculated the other two predicted stormflows using the new tool ('simulated monthly ex.'), and the standard daily CN method ('simulated daily'). We compared the observed and predicted stormflows using two different statistical measures. The coefficient of variation of the root mean squared error, CV(RMSE), measures how well the graphs of predicted and observed stormflow match in shape. The annual percent error (APE) measures how well the predicted total runoff for the year matches observed. We ran these tests at four USGS sites where we were able to calculate a meaningful CN.

We determined that, except for a slight discrepancy at Curlew Creek in the CV(RMSE), daily works best, then exponential, then mean. This suggests that our modification works fairly well and certainly better than simply using the average. Given the exciting first findings of this monthly CN method, a possible avenue of future research might be to find and assess more sites in varying climates across the United States or the world. (Supported by the Gordon and Betty Moore Foundation, Stanford University and the Stephen Bechtel Fund, CEEDS)

Advisor: Andrew Guswa

References:

¹Dingman, S. Lawrence. Physical Hydrology. 2nd edition. Long Grove, IL: Waveland Press Inc. 2008, 445-450.

HYDROLOGIC MODEL COMPARISON

Meyer and Signell

These diagrams display the stocks and flows of three models we reviewed in cross-sectional view. We created each diagram along the same visual template to facilitate comparisons. Color-coded stocks are arranged vertically from surface, soil zone, and unsaturated zone down to saturated zone. Stocks tracked explicitly within model codes are highlighted by darker borders while implicit stocks lack borders. Flows are depicted by blue or green arrows. We included details of lateral flows along their arrows, giving the variable name followed by dependencies in parentheses. These diagrams omit snowmelt processes and routing in stream channels.

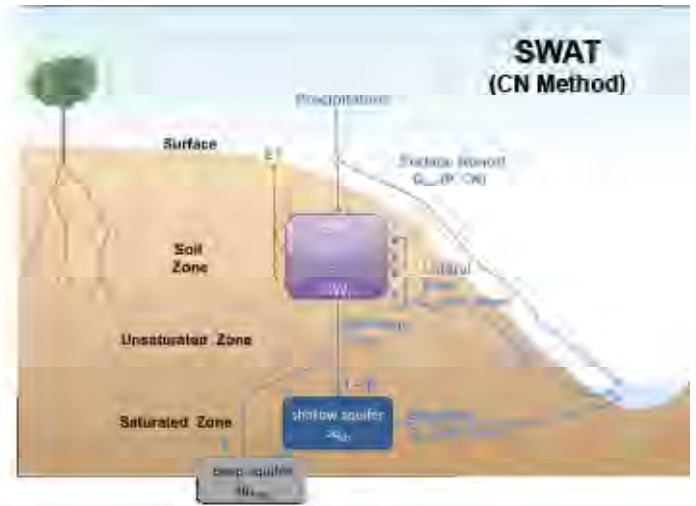

In wetlands and low gradient areas, HSPF users may choose an alternative soil hydrology representation. See pp. 70-82 of manual.

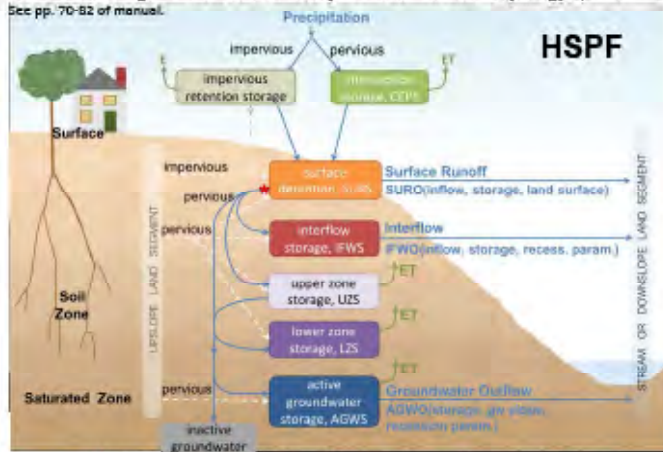

See pp. 85-88 of manual for methods used to partition recharge supply on pervious-land segments

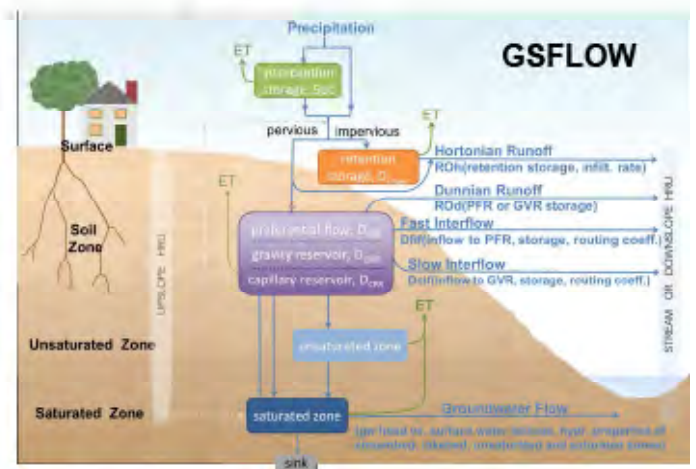

Measuring Otoacoustic Emissions Using HearID and Acoustic Processing Hardware

Erika Miguel

This summer, I conducted engineering research in Susan Voss' laboratory for five weeks. I focused on three main projects: power reflectance measurements; utilizing a MOTU audio mixer to make DPOAE measurements (via MATLAB programs); and programming TDT Real-Time Processors to generate tones and record them.

I have been taking power reflectance measurements with my lab partner, Defne Abur, since Fall 2011. This summer has been a continuation of this work. The goal of this research is to analyze the intrasubject and intersubject variability in power reflectance measurements in three different locations of the ear over an approximately ten week time period. The procedure for new subjects involves an ear examination with Susan Voss for approval to participate in the study. Once approved, we administer a one-time only hearing test of the subject. Then, for every visit over the ten-week time period, we measure the difference in pressure between the middle and outer ear through a tympanometer test and proceed with three power reflectance measurements, in different locations, in both ears.

There were multiple stages to this MOTU Audio Mixer for DPOAE Measurements project. First, I had to understand how the MOTU worked at its most basic level, as a music recording audio mixer. I spent the first two weeks of my research learning how to control the mixer through its pre-installed programs, how to navigate its interface without computer control, and how to produce sound from the mixer through speakers that were hooked up to the console and from the computer itself. Then, I had to understand ARLas, a MATLAB-based audio software that can perform various otoacoustic experiments. Prior to making actual measurements, I had to work through bugs and glitches in the program, which often meant being in contact with the program creator himself. After working through those technical difficulties, I have since been taking and analyzing distortion product otoacoustic emission (DPOAE) measurements on my own ears. This involves placing a probe into my ear canal and listening to two tones. In the fall, I will continue to analyze the ARLas program code and understand how it works from a computer scientist's perspective and will specifically look at how it saves data and how to plot and retrieve it.

There, too, were multiple stages to my Programming TDT Real-Time Processors project. I spent the three weeks of my research diagnosing a computer hardware issue that involved making a TDT PO5 card to work on Susan's desktop system so that the computer can communicate with the processors. After fixing the computer, I had to understand how the TDT RP2.1 (Real-Time Processor) worked; I did this by reading the product descriptions on the manufacturer's website. Then, I had to learn a new programming language, RpvdsEx, so that I could control the processors from the computer. RpvdsEx works by making circuit designs connected in a diagram-like fashion, which is not common to regular computer languages. From there, I needed to understand how RpvdsEx worked in conjunction with ActiveX so that I could program the RP2 in MATLAB.

I have since figured out how to generate tones on the RP2 and graph them in MATLAB. I will continue this research in the fall. (Supported by the National Science Foundation)

Advisor: Susan Voss

Modeling and Analysis of Thermal Dynamics in Miniature PEM Fuel Cells

Xinyi Liu

A fuel cell is a device that converts the chemical energy of a fuel into electricity. Every fuel cell consists of a cathode, an anode and an electrolyte. The most commonly used fuel is hydrogen. When hydrogen reacts with oxygen, power is generated by the fuel cell. The type of fuel cell used in our lab is a miniature Polymer Electrolyte Membrane Fuel Cell (PEMFC), with a catalyst coated active area of 5cm^2 . Even though PEMFCs contain many advantages over other types of fuel cells, such as being lighter, more compact, and responsive to dynamic loads, temperature and water management remain technical barriers to successful commercial implementation.

A control-oriented mathematical thermal model was developed and experimentally validated to predict the thermal performance of the miniature PEMFC, which operates with no humidification or reactant pre-treatment. After performing control volume analysis and applying an energy balance for the cell, the thermal model was constructed in Simulink and analyzed in MATLAB.

The miniature PEMFC was operated on a test bench under changes in load, air mass flow rate, and cathode inlet temperature. With the experimental data obtained, the model was tuned to identify unknown parameter values, followed by an experimental validation for that model. The thermal dynamic response of the model was compared with the experimental. Our model accurately captures most of the changes in load and in air mass flow, but further modifications to the model still needs to be made.

The SURF summer research introduced me to the field of fuel cell study and provided me with a rich summer experience. Under the guidance of my research advisor, I gained a deeper understanding of both fuel cell thermal-modeling techniques and how to carry out academic research. The work we did during the summer has been submitted as a conference paper to the ASME/IEEE American Controls Conference. With the knowledge built and techniques learned during the summer research, I will continue work on the thermal dynamics modeling of our fuel cell in my junior year as a Special Study. (Supported by the Schultz Foundation)

Advisor: Denise McKahn

Designs of Learning Environments in Undergraduate Engineering Education

Yanning Yu

The US Accreditation Board for Engineering and Technology (ABET) sets a variety of technical and nontechnical outcomes for students of engineering programs. These outcomes include the ability to work collaboratively, to engage in lifelong learning, and to understand social and professional responsibility. We believe that the twelve Knowledge Building principles can be an ideal guide to pedagogical innovations in engineering education that would effectively address those ABET outcomes, and engage students to learn deeply and act responsibly in complex real situations.

To understand how to bring Knowledge Building into the context of engineering education, an instructional prototype was designed and implemented in an undergraduate engineering course. The prototype included several features intended to facilitate various aspects of knowledge building. The student discourse generated on Knowledge Forum is being analyzed to assess the strengths and weaknesses of the current instructional design. Preliminary results suggest an impact of the designed features of the learning environment on student participation and idea-improvement. The results also show spontaneous engagement in the ethical, social, and cultural dimensions of the students' knowledge building work.

This work has been presented at the 2012 Knowledge Building Summer Institute (KBSI 2012, Toronto, ON). I will continue to work on this project as the honor thesis in my senior year. (Supported by the Schultz Foundation)

Advisor: Glenn Ellis

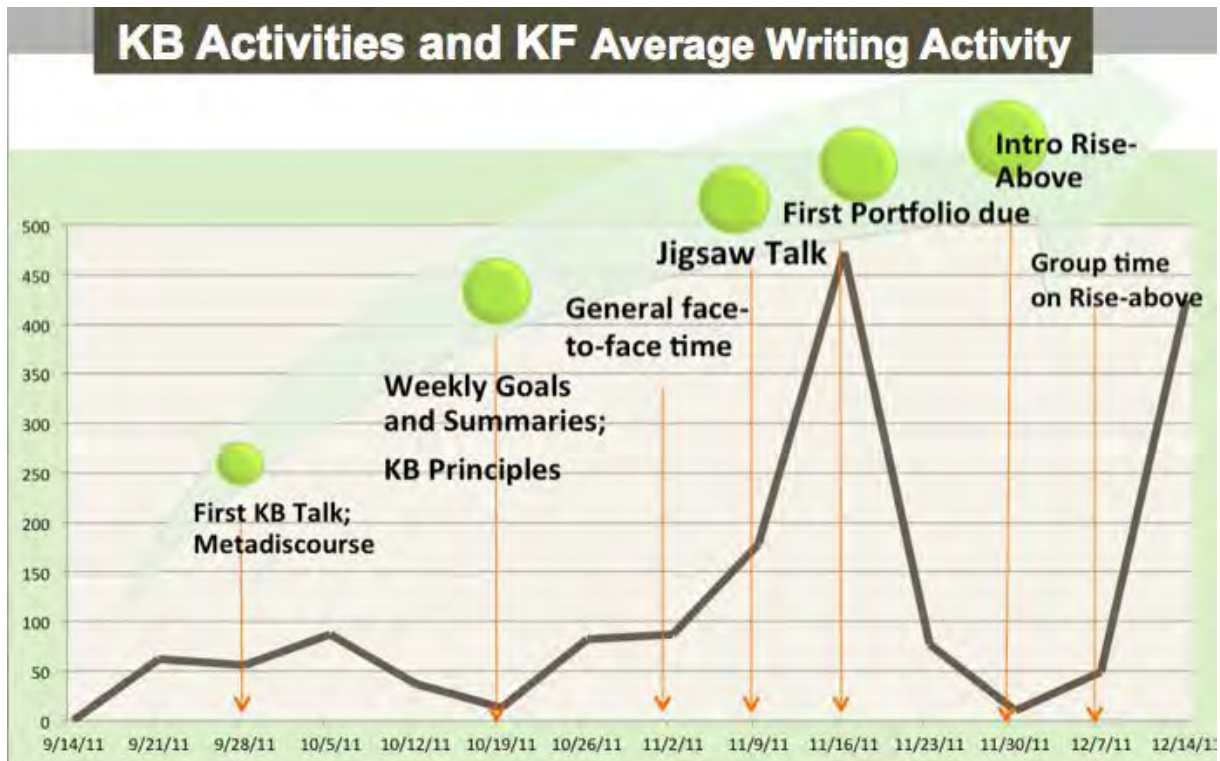

Electricity Consumption Monitoring System

Zhouchangwan Yu, Rumbidzai Vushe and Yamin Tun

One of the big challenges of maintaining the sustainability of our campus is to control the electricity usage and save energy in a collective way. This electricity-monitoring device is developed to make the electricity usage measurements of campus buildings and houses accessible to the people in the building and alert them if the electricity consumed exceeds the usual needs.

An Arduino board, an open-source microcontroller, is programmed using a wiring language named Arduino. The circuit is mainly built of an Arduino board, an Ethernet shield and cable, and a prototyping shield stacked on top of each other. Two RGB LEDs (tri-colored LEDs) are connected through a light pipe. The Arduino program is designated to extract the real-time electricity usage data from the Autologic html page via Ethernet, to display the data on a LCD screen and to change the colors of LEDs depending on the electricity use in the building. The circuit is powered by a 9V battery and enclosed in a white acrylic box.

The device displays the current electricity consumed and other related information such as the accumulated electricity consumed and the average electricity consumed for today. The device glows lights in three colors (green, yellow, red) depending on the current power used in the building. For the general user, we included the colored LEDs to give a sense of whether the electricity use is more than the average need of the building in three colors. According to the feedback, the users can have a better sense of how much electricity they are consuming and take further actions to reserve energy and costs.

Since the general users will rely mostly on the colors as the feedback, it is very important to determine the reasonable thresholds for the electricity usage levels. In order to do that, we are in the progress of studying the electricity usage data of each individual house and building in different periods of the past years. We will continue this project as a Special Studies project during the academic year. (Supported by the National Grid and the Summer Undergraduate Research Fellowship, Smith College)

Advisor: Judith Cardell

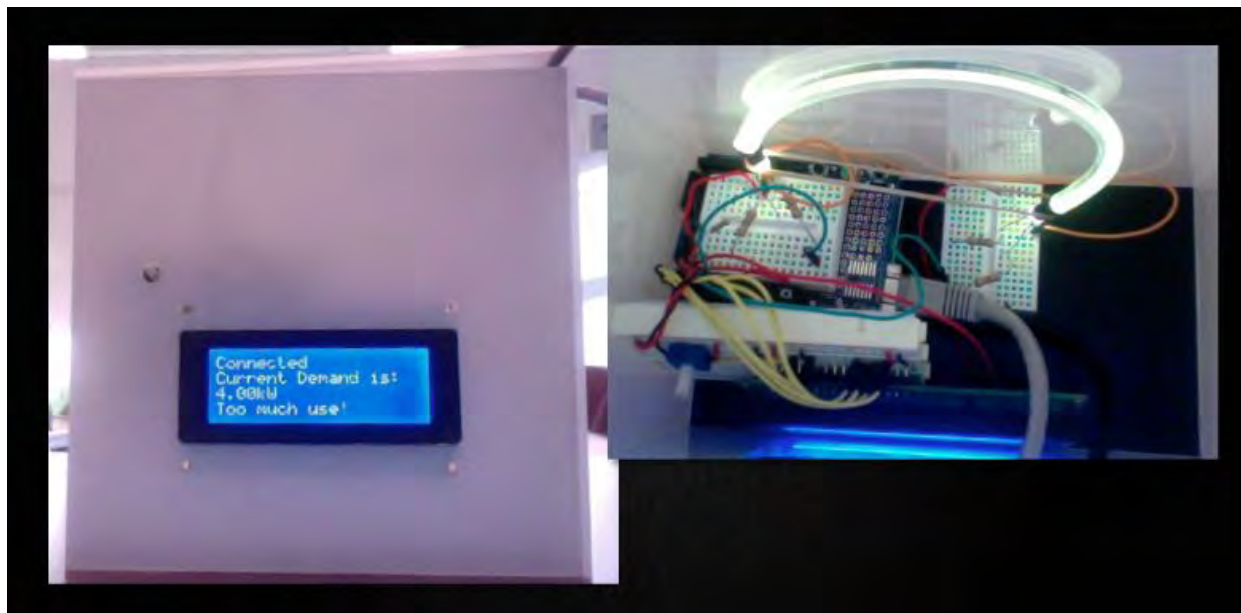

Science Communications and Legislative Outreach in a Federal Agency

Janet Burke

NOAA's National Centers for Coastal Ocean Science, (NCCOS), is a branch of NOAA's National Ocean Service in which coastal research is performed. This research is funded either by congressional mandates and appropriations or by partners interested in working with NOAA's expert scientists. In times of budgetary uncertainty, NCCOS is considering efficient communications and legislative/partner outreach in order to ensure that knowledge of NCCOS science and capabilities reaching the appropriate parties. My work at NCCOS this summer was focused into two areas: assessing the existing legislative and partner outreach efforts within NCCOS and formulating improved protocols, and helping with the NOAA Ocean Science Blog, which features short summaries of current NCCOS research.

The legislative/partnership aspect of the internship was my primary project. Partnerships are a very important aspect of legislative affairs, as partners of NCCOS may be in a better position to make the NCCOS message available to legislators than the NCCOS itself. The project required consensus from NCCOS leadership at several intervals. Initially, my internship supervisor, Rebecca Wynne, and I met with the director of NCCOS to determine the direct goals of a legislative/partner outreach effort. We then gathered and organized a comprehensive list of existing NCCOS partners, determining where the partner fit in to NCCOS strategic goals and needs. We then met with NCCOS leadership to get input on the partner list and develop a protocol for choosing partners strategically in the future. We also developed and shared a presentation outlining best practices for reaching out to partners and maintaining strong relationships with them.

My work on the NOAA Ocean Science Blog connected me to the communications aspect of NOAA research. I helped researchers convert their findings into blog entries that were directed to the general public. I also monitored the statistics on the blog to see which articles were getting the most hits and looked for connections to other press actions to help understand why some articles were being read more than others. Often the blog entries were posted in conjunction with the release of a scientific report, and the blog served as a "mini press release" for that report. The NOAA Ocean Science blog served the important purpose of spreading awareness of the work that NCCOS is engaged in outside of NOAA.

This experience was a good lesson about the way a federal agency works as opposed to the non-government, non-profit organizations I have worked for in previous years. As a federal agency, NOAA/NCCOS has to adhere to certain limitations in how they communicate with legislative officials and partners. The NOAA agency brand has to be protected as well as promoted. Any activities in the communications realm required consensus from center leadership as well as NOAA-wide offices, creating a unique suite of challenges for legislative outreach and science communications. (Supported by the Agnes Shedd Andreae 1932 Research Internship Fund)

Advisors: Joanne Benkley and Rebecca Wynne, Center for Coastal Management and Assessment, National Centers for Coastal Ocean Science, National Oceanic and Atmospheric Association (NOAA)

Marine Mammal Health and Toxicology

Victoria Dunch

Coastal waters in the United States have become highly contaminated with pollutants as a result of industry, development and general non-point source pollution. The effects of these pollutants, which may bioaccumulate in the environment, are not well understood, but are believed to have a serious effect on marine mammal health. High concentrations of various pollutants such as Polychlorinated biphenyls (PCBs), Polybrominated diphenyl ethers (PBDEs), Perfluorocarbons (PFCs) and pesticides such as DDT have been found in blubber samples of Atlantic bottlenose dolphins (*Tursiops truncatus*).¹ PBDEs, for example, are used as flame retardants on a wide variety of products including building materials, electronics, furnishings, plastics and textiles. At high concentrations it is believed that these pollutants can compromise an animal's immune system, which could contribute to mortality events either directly or indirectly from a compromised immune system allowing pathogens to invade. Bottlenose dolphins are apex predators, and thus accumulate high levels of pollutants from the environment. By studying the effects of toxins on these animals we may also grasp an understanding of their effects on us.

Several projects have been undertaken to study the effects of chemical contaminants on these animals. One is the Bottlenose Dolphin Health and Risk Assessment (HERA) Project, which aims to assess the health of two populations of bottlenose dolphins in two estuarine areas on the United States' eastern coast, Charleston, South Carolina (CHS) and the Indian River Lagoon, Florida (IRL). Over the course of two weeks beginning in June 2012, we received eleven skin samples obtained from dolphins captured and released in the IRL site. These samples were then incubated at 37° C and 5% CO₂ for twelve days in the hopes of growing fibroblast cells which we would then freeze down for cell storage and future testing. After about six days, the flasks of skin samples had to be observed daily for changes and fibroblast growth. Although unfortunately our samples became contaminated, most likely by a fungus, I learned sterile laboratory techniques and gained skills in cell culture methods.

A tremendous amount of preparation is needed in order to conduct a dolphin health assessment study. I contributed to preparing the sample preparation kits for the collection of gastric, fecal, blowhole, urine, and blubber samples which will be used for the dolphin health assessment study in Charleston next summer. I was responsible for sterilizing necessary equipment, labeling and constructing the field kits and creating an inventory of all the various sample supplies such as veterinarian animal supplies, tubes, needles, syringes, and vials.

A master's thesis immune study to evaluate the effects of DE-71, a mixture of flame retardant chemicals, on macrophages was also in process. Spleens from B6C3F1 mice were minced and 1 million yeast cells were added to the macrophages to mimic an invasive body for them to engulf. DE-71 was then introduced at environmentally relevant concentrations from 0.0, to 0.05, 0.25, 0.5, 2.5, 5.0, 25.0, and 50.0 µg/mL to determine if rates of phagocytosis differed.² This process was repeated on 30 slides which were then counted to determine the average engulfment rate for each concentration. I was involved in counting these slides on a Zeiss Axiovert S100 microscope to determine the percentage of phagocytosis.

I was able to count roughly 30% of the slides this summer and the trends suggest that DE-71 may have a negative effect on macrophage phagocytosis. With the plethora of contaminants now found in marine environments, and with new chemicals being released every day, it is of increasing importance to better understand the effects of such pollutants on human and marine mammal health. (Supported by the Agnes Shedd Andreae 1932 Research Internship Fund)

Advisors: Joanne Benkley and Patricia Fair, Center for Coastal Environmental Health & Bimolecular Research, National Oceanic and Atmospheric Administration (NOAA)

References:

¹Fair, Patricia A. et al. 2010. Contaminant blubber burdens in Atlantic bottlenose dolphins (*Tursiops truncatus*) from two southeastern U.S. estuarine areas: Concentrations and patterns of PCB's, Pesticides, PBDE's, PFC's and PAH's. *Science of the Total Environment*, 408. 1577-1597.

²Wirth, Jena R. *Emerging Contaminants in the Marine Environment*: Master Thesis. 2012.

Possible Seagrass Bed Fragmentation over Two Decades in Carteret County, NC

Karen Gilbert

Seagrass beds are habitats of great importance as they provide food for many organisms, protect and support larvae, and stabilize sediment to protect shorelines from erosion. Ferguson and Korfmacher state that alteration of current and salinity patterns, tidal ranges, water depth, and water quality threaten seagrasses.¹ Seagrass beds require constant monitoring for population change because they play a vital role in commercial and recreational fisheries. This research compares two study areas near developed and undeveloped barrier islands in Carteret County, NC, where seagrass bed fragmentation may be occurring. It is possible the damage from natural and unnatural disturbances, such as hurricanes, sea-level rise, dredging, and boat traffic can indicate where fragmentation will occur.

Seagrass beds in two areas were mapped using data from three different years (1992, 2006, and 2012) from high quality aerial, plane-mounted, and satellite image sources. The northern study area is Drum Inlet in Core Sound, which is one of the last inlets in a North Carolinian barrier island left to change naturally through storms and other events without dredging or other human interference. The southern study area is near Atlantic Beach in Bogue Sound. This location is surrounded by completely developed land and is vulnerable to boat disturbance. Both of these mapped areas of seagrass were classified as dense or patchy; classification was verified through ground-truthing and the changes were quantified using geographical information system technology.

Preliminary analysis suggests that fragmentation is occurring in more areas at Bogue Sound than at the Drum Inlet area. This is possibly due to the increased human impact in Bogue Sound, such as developed land, dredging, and recreational boat traffic. Because the Drum Inlet area is remote and undeveloped, the seagrass seems to be fragmenting in fewer areas. Future research should determine the present amount of natural and unnatural disturbance in Core Sound and Bogue Sound and surrounding areas and will ask how much these disturbances are actually causing fragmentation. This research will extend into a Special Studies project in Fall 2012 and will be presented at the Agnes Shedd Andreae Fellowship Symposium at Smith College. (Supported by the Agnes Shedd Andreae 1932 Research Internship Fund)

Advisors: Paulette Peckol, Sara Pruss and Don Field, PhD, National Oceanic and Atmospheric Administration (NOAA), Applied Ecology and Restoration Research Branch, Beaufort Laboratory, North Carolina

References:

¹ Ferguson & Korfmacher, 1998. Remote sensing and GIS analysis of seagrass meadows in North Carolina, USA, 242.

Increasing Native Olympia Oyster (*Ostrea lurida*) Recruitment

Elizabeth Gillespie

Elkhorn Slough, an estuary which empties into Monterey Bay on California's central coast, has been home to native Olympia oysters (*Ostrea lurida*) for at least 10,000 years. However, due to over-harvesting in the twentieth century and changes in habitat, *O. lurida* numbers in the Slough have declined.¹ Shellfish restoration has gained importance in recent decades in recognition of the ecosystem services that bivalves supply; among these are commercial and recreational harvesting, food or refuge habitat for other organisms, and water quality improvement by suspension-feeding.

Researchers at the Elkhorn Slough National Estuarine Research Reserve (ESNERR) are studying factors that contribute to recruitment limitations of Olympia oysters. One project examines the effect of dissolved oxygen fluctuations on oyster development and mortality; another study is exploring what types of artificially placed substrate is most successfully used by oysters. In a third experiment begun in 2008, a series of ceramic tiles, 25x19.9 centimeters, were deployed to act as recruitment substrate in spring 2011, at 9 sites within, or associated with, the ESNERR. Where the sites are fully influenced by tides, the tiles were hung from ¾ inch polyvinylchloride (PVC) pipes inserted into the mud in lines of 5 at three different tidal elevations: -1.5, 0, and +1.5 feet from mean lower low water (MLLW). This was done to examine the relationship that tidal elevation may have on oyster recruitment and competition. At sites of muted tidal influence (e.g., at culverts), tiles were deployed at -0.5 feet MLLW; due to the narrow intertidal zone at such sites, the primary concern was to maintain submersion. All tiles were suspended by plastic zip-ties that maintained acceptable distance above the mud substrate.

The tiles are replaced and examined annually. In June 2012, the research team noted and measured any oysters on the year-old tiles, identified other species competing for the hard substrate, and determined the percent cover of competitors. Although the data set is small and the study is ongoing, results indicated that two invasive species (the bryozoan *Bugula neritina* and the polychaete *Ficopomatus enigmaticus*) may be factors in the competition for hard substrate in the generally soft-bottomed estuary. Additionally, the data is being used as researchers determine how and where to deploy artificial oyster reefs.

Through past and current research, it is clear that many factors influence recruitment success of Olympia oysters. Their narrow range of habitat (mid- to low intertidal locations in estuaries and sheltered bays), moderate salinity and other water quality requirements, and need for hard recruitment substrates complicate restoration by Reserve managers. Additionally, competition from non-native species may further decrease available recruitment opportunities. The research underway and the mitigations implemented at ESNERR increase researchers' understanding of the scope of the situation and continue to reveal options for the future. (Supported by the Agnes Shedd Andreae 1932 Research Internship Fund)

Advisors: Joanne Benkley, Kerstin Wasson, National Oceanic and Atmospheric Administration, Elkhorn Slough National Estuarine Research Reserve and University of California, Santa Cruz (NOAA)

References:

¹Wasson K. Informing Olympia oyster restoration: evaluation of factors that limit populations in a California estuary. *Wetlands* 2010; 30:449-459.

Coral Reef Ed-Ventures 2012: An Environmental Education Program Conducted by Smith College Students for Youth in San Pedro, Belize

Kayla Clark, Lauren Malecky, Kaylyn Oates, Angela Oliverio, Alyssa Stanek, and Megan Svoboda

*“Come on down, we’re going to see the mangroves!
Come on down, we’re going to see the sea!
All the fish are swimming at the bottom,
Helping us to protect the sea!”*

Belizean children participating in the 2012 Coral Reef Ed-Ventures program sang these words as they walked to the mangrove restoration site that was planted by the previous year’s students. The lyrics were part of a song they created about mangroves, which they later performed at a graduation ceremony for over 250 members of the San Pedro community.

These children live on the island of Ambergris Caye, Belize, in close proximity to the Meso-American Barrier Reef which is the largest barrier reef in the western hemisphere. The island’s largest settlement, San Pedro, is the premier vacation destination in Belize and is economically and ecologically dependent on the reef. It is imperative that the reef be protected, as its degradation and collapse would result in devastating consequences for the island and its inhabitants.

Now in its thirteenth year, Coral Reef Ed-Ventures is an environmental education program run by Smith College’s Environmental Science and Policy Program in collaboration with Hol Chan Marine Reserve on Ambergris Caye. This program for San Pedro’s school children is designed to increase awareness of the environmental and economic benefits of a healthy reef ecosystem. The six undergraduate students that organized and led the 2012 program represented various fields of study at Smith College, including environmental science, anthropology, sociology, and education. One of the objectives this year was to strengthen the program’s involvement with Hol Chan Marine Reserve, bringing their staff and conservation efforts more fully into the educational component of our program and identifying new research directions that would help Hol Chan in their efforts to conserve and manage the reef.

The educational program that Smith students run is comprised of two parts: youth camp (ages 7-11), and advanced camp (ages 12-16). The camp curriculum is designed so that by its conclusion, campers are able to demonstrate significant knowledge of the coral reef environment and identify reef organisms, possess an understanding of adaptations and symbiotic relationships, can discuss threats facing the reef, and can brainstorm ways that they can positively impact conservation efforts and contribute to the sustainable use of natural resources. During this year’s youth camp, children explored reef ecology through field trips to the beach and reef. They had presentations from Hol Chan guest speakers and engaged in creative activities, such as art projects and games. In addition to teaching coral reef ecology, the Smith students provided their students with the skills they may need to educate their community on coastal conservation.

This year, over one hundred students attended the two-week youth program. Highlights of the camp included an “edible” coral polyps project and a glass bottom boat trip. To visually track their progression of knowledge, students worked on a mural that illustrated four marine ecosystems from shallow to deep water through mangroves, shallow sea, coral reefs, and deep sea. At the graduation ceremony, a tradition that ends camp each year, students performed skits, songs, and dances that they created, innovatively sharing the wealth of information they had learned.

In addition to the youth camp, Smith students also conducted a weeklong advanced camp for children ages twelve and older. The advanced campers participated in research with Hol Chan Marine Reserve. Advanced campers collected and analyzed seagrass samples using a protocol established by SeaGrassNet, an ecological monitoring program that investigates and documents the status of and threats to seagrass worldwide. As a result, campers were able to explore seagrass environments and their importance, as they simultaneously learned about scientific research methodology.

The Smith undergraduates also conducted research of local ecosystems in collaboration with Hol Chan Marine Reserve. Led by their professors, students engaged in four different projects. First, they helped monitor turtle nests and created beach profiles of nesting sites. Second, Smith students analyzed seagrass data collected by the advanced campers to gain an awareness of seagrass health. Third, in an effort to assess and monitor coral reef health, students photographed transects of key coral reef areas, comparing algal cover on live and dead coral and estimating sea urchin density. Finally, they mapped mangrove and lagoon sites using GPS/GIS technology and aerial photographs taken from kites. This new line of research was supported by Jon Caris, Coordinator of Smith's Spatial Analysis Laboratory.

Coral Ed's emphasis on place-based learning and inquiry brought an increased level of community involvement. The multiple research endeavors were very beneficial to our relationship with the Hol Chan Marine Reserve and contributed to our understanding of conservation and sustainability on Ambergris Caye. We look forward to maintaining these partnerships and seeking new collaborations in the future. (Supported by B. Elizabeth Horner Fund, Agnes Shedd Andrae Fund, and the Center for Community Collaboration)

Advisors: H. Allen Curran, L. David Smith, Denise Lello, and Miguel Alamilla, Jr., Manager of Hol Chan Marine Reserve



Kirah Forman, a biologist from Hol Chan Marine Reserve, visits advanced camp to speak about seagrass.



Youth campers enjoy an afternoon spent on the glass bottom boat!



Kaylyn leads two advanced campers in gathering seagrass samples.



Children from youth camp start the morning by making a Great star coral out of fabric and pipe cleaners for the mural.



When researching local ecosystems, Smith students used kite aerial photography to collect images of mangrove and lagoons.



Smith students worked with Hol Chan Marine Reserve and WWF professors to create beach profiles of turtle nesting sites.

Effect of Habitat Structure Formed by Macroalgal Foundation Species on Associated Fauna in Rocky Intertidal and Marsh-Cordgrass Ecosystems

Emily Peake

.....

Habitat structure can have a profound impact on functions of an ecosystem. A study which looked at the two algal foundation species in the marsh-cordgrass ecosystem found that the two work synergistically in how they provide a habitat for epifaunal species in that ecosystem.¹ However, little is known about the difference in structural habitat provided by the macroalgae in the rocky intertidal (*Fucus vesiculosus* and *Ascophyllum nodosum*) and salt marsh areas (*Fucus vesiculosus* ecad and *Ascophyllum nodosum* ecad). Our summer research focused on two primary questions: 1) What is the difference in the structural habitat provided by macroalgae in rocky intertidal areas and the morphologically distinct ecads of the salt marsh areas? 2) How does the difference in the structural habitat affect snails (*Littorina* spp.) and crabs (*Carcinus maenas*)?

The primary methods used to quantify differences between rocky intertidal and marsh-cordgrass macroalgae included an analysis of photographs oriented both vertically and horizontally to the algae mats at low tide. These photographs enabled us to quantify the complexity of both species in each ecosystem by measuring surface convolution and the frequency and size of interstitial spaces within the growing algae. Another method used was a series of predation trials; during which forty wire-mesh cages containing algae, snails and crabs were deployed in the low salt marsh zone over a period of one week. This experiment tested the ability of each algae to provide a refuge for snails from crab predation. A second experiment conducted during the summer was a snail growth experiment, in which snails were placed in individual mesocosm containers in an environmental chamber for up to five weeks. This experiment examined the preferred food sources for two snail species. We also conducted species surveys at all sites in order to estimate the size and density of snails and crabs and the average biomass of algae in the different areas. All experiments and fieldwork were conducted at the Wells Nation Estuarine Research Reserve in Wells, Maine (43°20'12.80" N, 70°32'28.43" W), at nearby Kennebunk Middle Beach in Kennebunk, Maine (43°23'04.31" N, 70°32'38.36" W) and at Perkin's Cove in Ogunquit, Maine (43°14'50.03" N, 70°36'25.68" W). Preliminary results showed ecads of the marsh-cordgrass area being more complex in terms of interstitial space and surface convolution analyses than algae growing in the rocky intertidal zones. (Supported by the Agnes Shedd Andreae 1932 Research Internship Fund)

Advisors: Joanne Benkley and Jennifer Dijkstra, PhD National Oceanic and Atmospheric Administration (NOAA), National Estuarine Research Reserve, Wells, ME

References:

¹Dijkstra, J.A. et al. 2011. Species-specific mediation of temperature and community interactions by multiple foundation species. *Oikos* 121: 646-654.

Center for the Environment, Ecological Design and Sustainability (CEEDS) Intern

Lisbet Portman

This summer I worked alongside two other SURF interns doing various projects: compiling data collected in Ward 3 of Northampton and creating a primer, building trails and crafting educational material at the Ada & Archibald MacLeish Field Station, and assistant teaching for a high school summer program which took place at Smith College.

At the Ada and Archibald Macleish Field Station I illustrated and wrote an educational manual outlining the birds species at the Macleish Field Station which will be used by visitors to identify and learn about common birds in the area. I also helped build a hiking and biking trail at the field station that will be used widely and often for years to come

I acted as a teaching assistant for Smith College's two-week summer camp, "Field Studies for Sustainable Futures," for juniors and seniors in high school. We traveled around the Pioneer Valley visiting various sites exemplifying sustainable practices. Some examples are as follows; the Macleish Field Station, farmers markets, Sirius eco-village, an urban permaculture garden in Holyoke, Crimson and Clover Farm in Florence, a landscape design firm, a roof garden, an edible walk, and much more. The students took movement classes in environmental dance, read material, kept journals, and designed on-site pieces for the Macleish Field Station. The camp occurred at the end of the internship, which allowed me to share elements of the projects I worked on throughout the summer with the students.

My involvement in the Ward 3 Community Involved Planning and Design Project led me to join forces with Marcia McNally and Reid Bertone-Johnson, who have led students through intensive data collection and design projects in this Ward for years. By analyzing and compiling maps, data, and designs, we created a primer outlining methodologies for approaching, interacting with, and activating projects within this particular cityscape. This primer will be used and the design proposals implemented by the Neighborhood Association, community activists and the Ward 3 City Councilor. We also collected additional data using Geographic Information Systems (GIS). (Supported by the Center for the Environment, Ecological Design and Sustainability)

Advisor: Reid Bertone Johnson

Comparing Throughfall Chemistry in a Mature Hemlock Forest and Early Successional Deciduous Forest at the MacLeish Field Station in Whately, MA

Jenna Zukswert

Removal of foundation species as a result of disturbance events can alter community composition and ecosystem function.¹ The current hemlock woolly adelgid (*Adelges tsugae*) infestation in eastern North America that threatens the eastern hemlock (*Tsuga canadensis*), a foundation species, has motivated salvage logging efforts.² Ecological succession following hemlock removal eventually results in a mature deciduous forest.¹ The chemistry of throughfall, precipitation that passes through the forest canopy and serves as an important nutrient input to the forest floor,³ is expected to be more acidic beneath a hemlock forest canopy than beneath a mature deciduous forest canopy because hemlock foliage releases more organic acids and fewer base cations. The chemical composition of the throughfall beneath a juvenile deciduous forest canopy, however, is less understood. We hypothesize that throughfall beneath a juvenile deciduous forest canopy will be more similar to direct precipitation because leaf area index is smaller. We compared the chemical composition of direct precipitation, hemlock throughfall, and black birch (*Betula lenta*) throughfall at the MacLeish Field Station for 26 precipitation events from March through July 2012. The juvenile black birch forest plot resulted from salvage logging of hemlocks twenty years ago. From the three plots we measured the volume of water collected and pH, acid neutralizing capacity, dissolved organic carbon (DOC), and concentrations of select cations (Ca^{2+} , K^+ , Na^+ , Mg^{2+} , NH_4^+), anions (Cl^- , NO_3^- , SO_4^{2-}), and dissolved silica.

We found that deposition of base cation and DOC (in kg ha^{-1}) were significantly ($p < 0.05$) greater in throughfall than in direct precipitation. Additionally, K^+ , Mg^{2+} , and DOC deposition were significantly and consistently higher in hemlock throughfall than black birch throughfall. Black birch throughfall had significantly less H^+ deposition than precipitation, which suggests that the black birch canopy neutralizes the acidity of the precipitation. H^+ deposition from hemlock throughfall was not significantly different from precipitation, which could be due to its higher DOC. These results suggest that the successional stage of a deciduous forest canopy has an effect on throughfall chemistry and consequently on the input of nutrients to the forest floor, where they are used by microbes and plants. I submitted an abstract describing this work to the Fall 2012 Meeting of the American Geophysical Union. I plan to resume this work in the fall as a component of my honors project in biology, for which I will compare nutrient cycling in hemlock and black birch forests. (Supported by the Schultz Foundation)

Advisor: Amy Rhodes

References:

- ¹Ellison, A. M., Bank, M. S., Clinton, B. D., Colburn, E. A., Elliott, K., Ford, C. R...Webster, J. R. (2005). Loss of foundation species: consequences for the structure and dynamics of forested ecosystems. *Frontiers in Ecology and the Environment*, 3(9): 479-486.
- ²Kizlinski, M. L., Orwig D. A., Cobb, R. C., & Foster, D. R. (2002). Direct and indirect ecosystem consequences of an invasive pest on forests dominated by eastern hemlock. *Journal of Biogeography* 29: 1489-1503.
- ³Prescott, C. E. (2002). The influence of the forest canopy on nutrient cycling. *Tree Physiology* 22: 1193-1200.

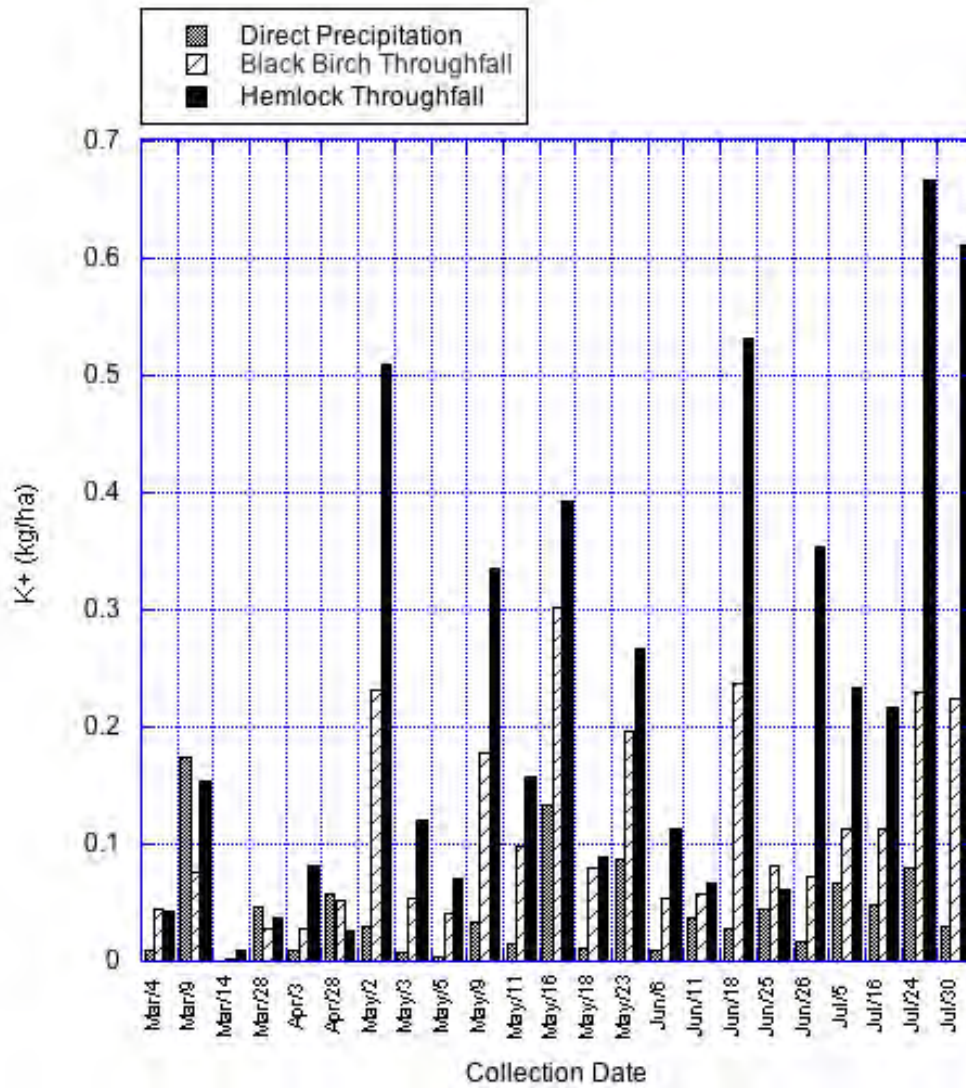

Figure 1. Potassium deposition (K+) over time in direct precipitation and in black birch and hemlock throughfall





Distribution and Origin of Caliche Crusts in Ancient Sand Dunes on San Salvador Island, Bahamas

Sarah Brisson



In January I conducted geological fieldwork on San Salvador to examine unusual features of eolian dune deposits formed by sedimentation and lithification of wind-blown carbonate sand. This summer I carried out petrographic and stable isotope analyses of collected samples. I described and photographed my samples, then cut them and made thin sections for examination under a petrographic microscope. Using a microscope-mounted drill I collected powder for stable isotope (oxygen and carbon) analysis. I will be presenting my results at the Annual Meeting of the Geological Society of America in Charlotte, NC this fall.

My research focused on numerous thin caliche crusts present in eolianites of the upper North Point Member of the Rice Bay Formation exposed along the northeastern coast of San Salvador. These eolianites formed during Holocene sea-level rise about 6 to 5 ka and consist of complexly stratified deposits produced by wind-ripple migration, grainfall and sandflow processes.¹ Such caliche crusts are not present in the lower part of these Holocene deposits or in the older Pleistocene eolianites. I examined the distribution and composition of caliche and compared them with Pleistocene deposits to better understand the formation of these unique features.

Caliche is a hard microcrystalline crust formed by dissolution and subsequent reprecipitation of carbonate. In the upper part of the exposure caliche coats all prominent bedding planes, including dune crests, gently sloping windward sides, and steep (up to 34°) leeward surfaces. In weathered exposures caliche also forms a step-like pattern of up to twelve crusts, 1-4 mm thick, separating 3-32 cm thick eolian beds that thin upsection. Most of these crusts are parallel to lamination and vary in orientation from horizontal to 18°. Others encrust cross-laminated beds and vertical fractures forming caliche dikes. Caliche crusts have a sharp, smooth upper surface with varying degrees of weathering which impart a pitted, irregular appearance. In most cases caliche crusts are associated with dense, laterally extensive rhizoliths that form by carbonate precipitation around plant roots.

Multiple caliche horizons represent coeval precipitation as penetrative caliche.² Plant roots penetrated through the eolianite, then spread laterally along firmly lithified laminae in search of water and nutrients. The presence of water and plant material facilitated caliche formation and produced a unique stratification pattern with numerous thin crusts delineating distinct beds of mainly wind-ripple laminated strata. This distinguishes the Holocene deposits from their Pleistocene counterparts, which commonly have thicker eolian strata separated by more varied and better-developed ancient soil horizons. Stable isotope analysis also demonstrated important differences in the composition of caliche and host eolian sediment from these strata. These differences reflect varying climatic and environmental conditions as well as differing duration and styles of eolian sedimentation and post-depositional modifications in the Pleistocene versus the Holocene in the Bahamas. (Supported by the Schultz Foundation)

Advisor: Bosiljka Glumac

References:

¹White, B. and H.A. Curran. 1988. Mesoscale physical sedimentary structures and trace fossils in Holocene carbonate eolianites from San Salvador Island, Bahamas. *Sedimentary Geology*, 55: 168-184.

²Rossinsky Jr., V., H.R. Wanless and P.K. Swart. 1992. Penetrative calcretes and their stratigraphic implications. *Geology*, 20: 331-334.

Geochemistry of Avery Brook, West Whately, MA

Katherine Broadwater

Avery Brook lies within a 756 hectare forested watershed located near West Whately, MA in the Conway State Forest. It is the primary water source for the City of Northampton's principle drinking water reservoir. It is a second order stream that includes a number of beaver ponds in the upper part of the catchment. The bedrock underlying the watershed is the Devonian age Williamsburg Granodiorite. Water samples were collected at fourteen sites within the stream system and included samples from beaver ponds and groundwater seeps. Water chemistry is influenced by weathering reactions occurring within the watershed soils as well as by biogeochemical reactions occurring in the beaver ponds during low flow periods in summer.

In the field, pH, temperature, and concentrations of dissolved oxygen and specific conductance were measured and water samples were taken at each of the sample sites. Samples were analyzed for Dissolved Organic Carbon (DOC), Specific Ultra-Violet Absorption (SUVA), anions by ion chromatography (F, Cl, NO₃, & SO₄), cations (Ca, Na, Mg, & K), trace metals (Zn, Fe, Mn, & Ba) by inductively coupled plasma optical emission spectroscopy, stable oxygen and hydrogen isotopes by cavity ring-down spectroscopy, and alkalinity by Gran titration. Stream discharge was determined at a gage station located near the outlet of the stream using a Campbell Scientific datalogger and Druk transducer that recorded stream stage at ten-minute intervals. Discharge was estimated from stage using a stage discharge relationship determined from velocity-area measurements using a Sontek acoustic doppler current meter and 6-tenths wading rod.

Calcium is the dominant cation in Avery Brook and there is a strong correlation between calcium and alkalinity. Calcium is most likely derived from weathering reactions in the till and bedrock and it is likely that the strong correlation with alkalinity is due to the weathering of calcite which is likely present in bedrock veins or in the metamorphic rocks surrounding the granodiorite. Bicarbonate is the dominant anion while sulfate is also high in upstream and groundwater seep waters.

During the summer, as water temperature increases and stream discharge decreases, the rate of organic decomposition increases in the beaver ponds leading to the loss of dissolved oxygen. This in turn leads to a decrease in sulfate due to the action of anaerobic sulfur reducing bacteria. During the warmest part of the summer the beaver ponds characteristically have very low sulfate and dissolved oxygen but also have high concentrations of iron and manganese as these metals tend to be mobilized under chemically reducing conditions.

During the fall, as stream discharge increases and water temperatures decrease, the dissolved oxygen of the beaver ponds increases along with the sulfate concentrations. Sulfate concentrations increase significantly above the concentrations in the streams entering the ponds suggesting the products of summer sulfate reduction are re-oxidized in the fall and released as a pulse of higher sulfate water. (Supported by the Schultz Foundation)

Advisor: Robert Newton

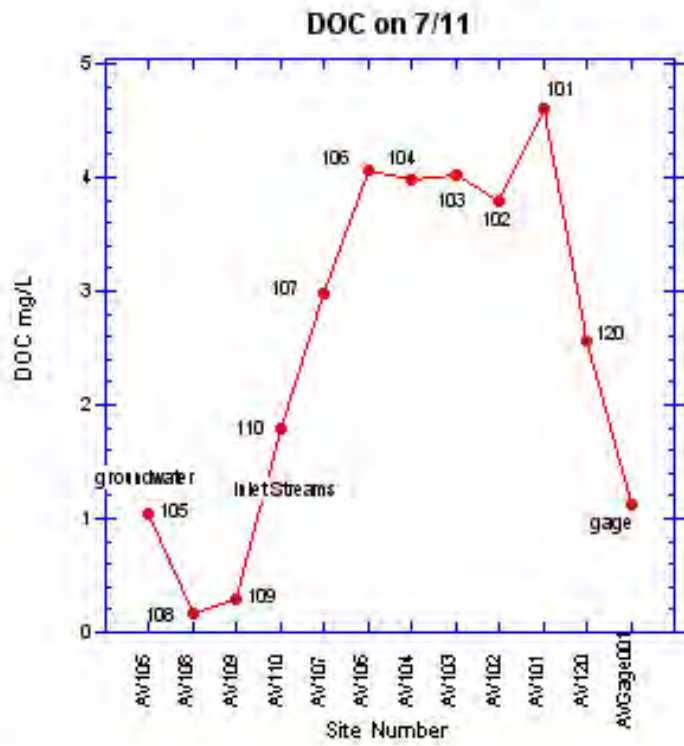

Figure 1. The beaver ponds (101, 102, 103, 104, 106, and 107) show the increased rate of organic decomposition.

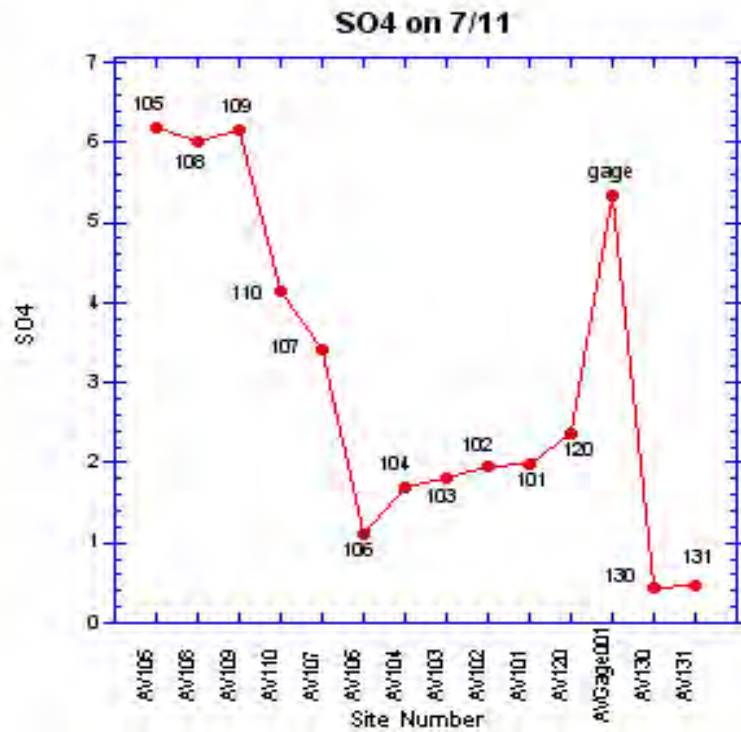

Figure 2. Characteristically low concentrations of Sulfate are found in the beaver ponds during one of the hottest months of summer.

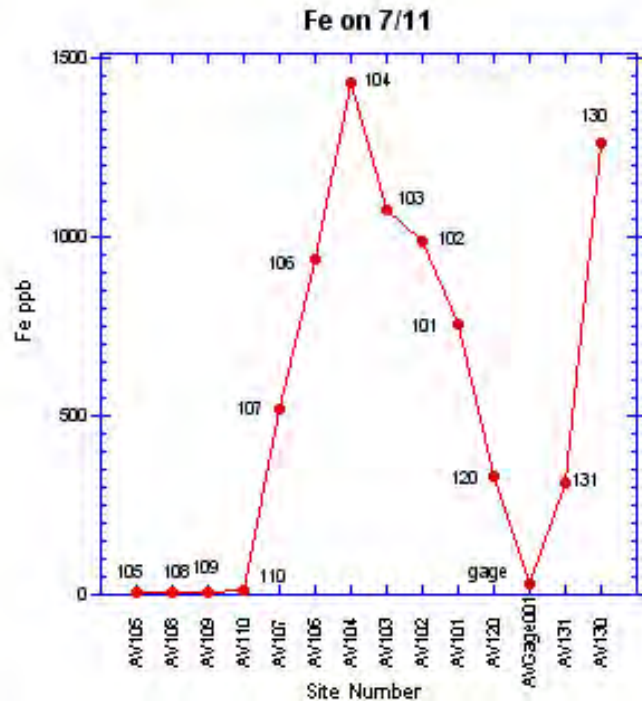

Figure 3. Iron levels in beaver ponds are highest during the hottest part of summer when sulfate levels are low.

Analyzing Systems of Earthquake-Related Landform Deformation along the Chilean Coastline

Paula Burgi and Alexandria Julius

A large subduction zone is present along Chile's Pacific coastline, where the Nazca plate is subducting under the South American plate. Stress induced on the upper South American plate by the lower Nazca plate causes differing physical expressions on the upper plate. In Southern Chile, the deformation takes the form of faults, which is expected in this tectonic setting. In Northern Chile, however, there is less large-scale faulting but rather, relatively small cracks in the ground. Our goal was to examine the different manifestations of stress and their origins. Factors for this discrepancy are the subduction zone geometry changing with geographic location, and variation of locking between the subduction zone and the upper plate, determining how much the lower plate slips relative to the upper plate.

Our main tool of analysis was mathematical modeling using MATLAB, a technical computing software program. Initially, we created an accurate 3-dimensional representation, in the form of a triangular mesh, of the subduction zone and the upper plate faults. Next, we calculated the partial derivatives of displacement and strain¹ imposed on the upper plate faults by the rate of subduction of the lower plate. With this information, we were able to calculate the stress imposed on the faults. We were also able to calculate slip along the faults by using the computed stress on the faults, and inverting the partial derivative calculations.

After determining the stresses on the upper plate faults, we statistically modeled the distribution of stresses in relation to geographical location. Figure 1 is a histogram of the three components of stress in Northern Chile versus Southern Chile. There is no significant variation in the distribution of stress between Northern and Southern Chile. Figure 2 represents the distribution of slip along the upper plate faults. The calculated slip, which would result from 150 years' worth of subduction zone locking, yields slip rates consistent with previous data.²

The consistency of stress between Northern and Southern Chile signifies that there may be other determining factors for the discrepancy in stress expression. Possible explanations may be the influence from areas of the subduction zone that were not included in our calculations, and geographic differences in rock rigidity, earthquake size and frequency, and occurrences of ancient structures. The results shown in Figure 2 indicate that our model estimates slip rates on faults along the Chilean coastline that are consistent with geologic studies. (Supported by the Jack Loveless Startup Fund)

Advisor: Jack Loveless

References:

- ¹Meade, B.J. 2007. Algorithms for the Calculation of Exact Displacements, Strains, and Stresses for Triangular Dislocation Elements in a Uniform Elastic Half Space. *Computers & Geosciences* 33.8: 1064-1075.
- ²Allmendinger, R. W., and G. González. 2010. Neogene to Quaternary Tectonics of the Coastal Cordillera, Northern Chile. *Journal of Tectonophysics* 495: 93-110.
- Moreno, M., D. Melnick, M. Rosenau, J. Baez, J. Koltz, O. Oncken, A. Tassara, J. Chen, K. Bataille, M. Bevis, A. Socquet, J. Bolte, C. Vigny, B. Brooks, I. Ryder, V. Grund, B. Smalley, D. Carrizo, M. Bartsch, and H. Hase. 3 Feb 2012. Towards Understanding Tectonic Control on the Mw 8.8 Maule Chile Earthquake. *Earth and Planetary Science Letters* 321-322: 152:165.
- Chlieh, M., H. Perfettini, H. Tavera, J. Avouac, D. Remy, J. Nocquet, F. Rolandone, F. Bondoux, G. Gabalda, and S. Bonvalot. Oct. 2010. Interseismic Coupling and Seismic Potential along the Central Andes Subduction Zone." *American Geophysical Union*, Vol 116.

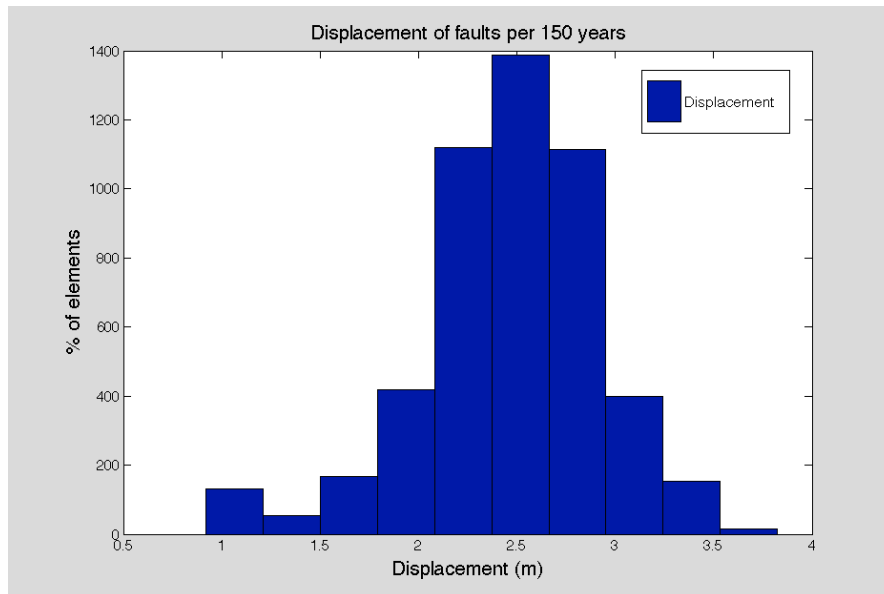
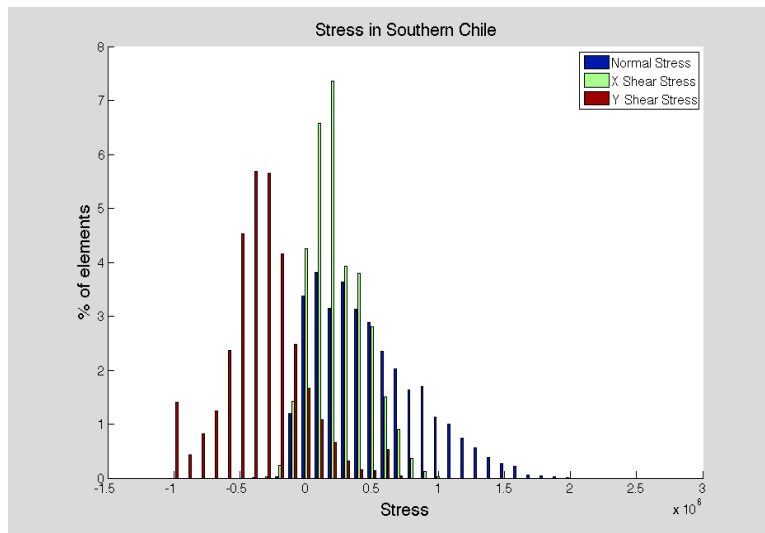
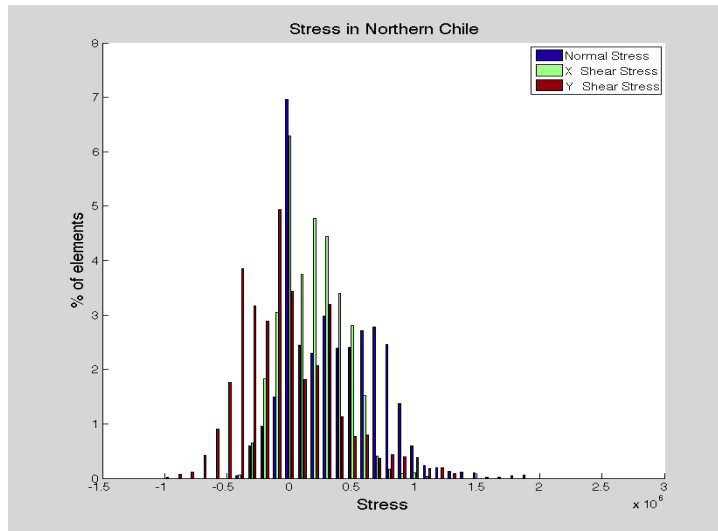

The Hemlock Woolly Adelgids' Impact on Throughfall of Northeastern Forests: Throughfall Black Birch Amounts are Greater than Throughfall Eastern Hemlock Amounts

Camille H. Dwyer

When an invasive species impacts a new environment, it becomes critical to observe the changing ecosystem. The hemlock woolly adelgid (*Adelges tsugae*) can greatly weaken the eastern hemlock (*Tsuga canadensis*) and the mortality of hemlock forest has been widespread in parts of southern New England.¹ Deciduous hardwood trees like black birch (*Betula lenta*) grow in the eastern hemlocks' place. To understand the altering ecosystem, adjacent, juvenile black birch (about 20 years old) and mature hemlock forest were examined for differences in rain throughfall amounts.

To see if early forest succession changes the volume of precipitation reaching the forest floor, we measured throughfall beneath juvenile black birch trees (site TF-SEBB) and mature hemlock (site TF-SEH). It is believed that the black birch leaf emergence will change the amount of throughfall; the percentage of black birch throughfall will decrease after the leaf-out date and will be significantly less than the percentage of hemlock throughfall. For comparison, we also collected direct precipitation in an open field (MCL-OPEN), which was checked against an automated tipping bucket (MCL-TB) which tipped when 0.254mm of precipitation accumulated.² Both TF-SEH and TF-SEBB had fourteen one-liter bottles topped with a funnel. TF-SEBB had dense undergrowth and a moderately thick canopy. Site TF-SEH had taller, but fewer trees. The canopy created a shadier site because of the canopy's abundance of hemlock needles. After each rain event, the throughfall and rainfall for TF-SEH, TF-SEBB, and MCL-OPEN was collected and measured in graduated cylinders with milliliter increments. We divided collected volume by the area of the funnel to find the depth in millimeters. For the dates of April 23, 2012 and June 4, 2012, the MCL-TB depth was used because the MCL-OPEN bottles leaked. By accounting for these dates, the MCL-OPEN and TB-MCL measurements had a correlation of .9954 and a slope of 1. There was a strong one-to-one correlation and a small margin of error between the two method collections.

Before leaf-out, the percentage of TF-SEBB is significantly greater than the percentage of TF-SEH. After leaf-out, the percentage of TF-SEBB is only slightly greater than the percentage of TF-SEH. Both percentages increased, but the percentage of TF-SEH increased more dramatically. This change may have more to do with rainfall depth than with the emergence of leaves, however. Only five events prior to leaf-out were sampled, and a larger sample size is needed for statistical comparison. In general after leaf-out, the black birch throughfall percentage was higher than the percentage throughfall at TF-SEH because the black birch canopy was not as dense as the hemlock canopy. The hemlock canopy intercepts more rainwater than the black birch canopy, particularly for smaller events. A bigger difference between TF-SEBB and TF-SEH occurs when throughfall is less than 10mm. On two occasions, however, the percentage of TF-SEH is greater than TF-SEBB when the amount of collected rainwater is less than 10mm (Figure 1).

These results show that more precipitation passes through the black birch canopy than the hemlock canopy. Even after leaf-out, the black birch was not as dense as the hemlock canopy. Large-scale forest succession from hemlock to black birch would result in more rain reaching the forest floor, creating wetter soil. This would alter the ecohydrology of New England that is currently occupied by eastern hemlock trees. (Supported by the S. D. Bechtel Fund)

Advisor: Amy Rhodes

References:

¹Ellison, A. M. et al. 2005. Loss of foundation species: consequences for the structure and dynamics of forested ecosystems. *The Ecological Society of America*, 3(9): 479-486.

²Wetzel, Paul. 2011. Notes and Information about the Meteorological Data from the MacLeish Field Station. 1-5.

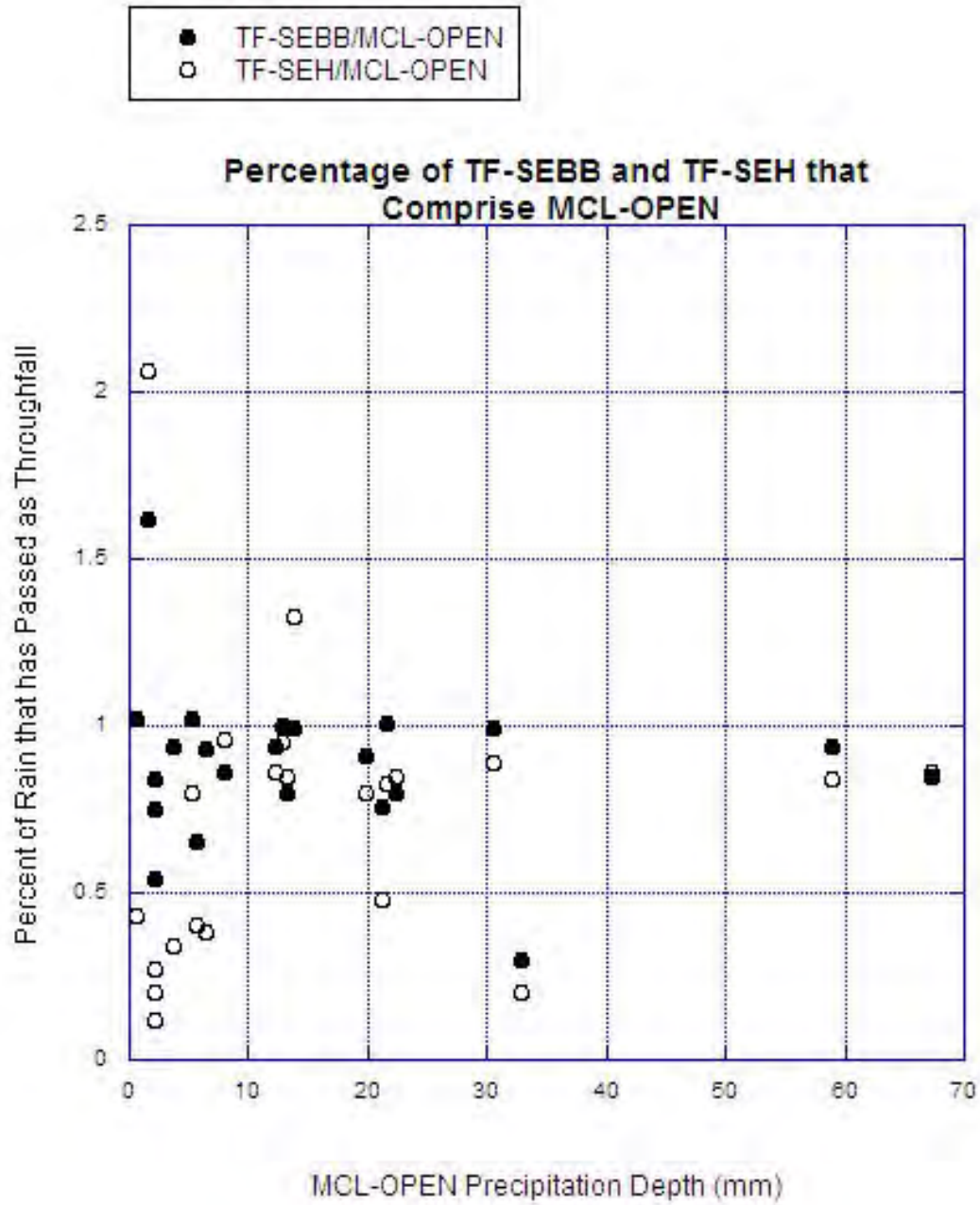

Figure 1- The Percentage of TF-SEH and TF-SEBB based off of MCL-OPEN depth.

Use of GPUs for Crustal Deformation Modeling

Alexandria Julius and Paula Burgi

To use MATLAB to mathematically model geological interactions and resulting deformations between subduction zones and upper plate faults, calculations are run on two triangular meshes. A loop in the MATLAB code is used to output the same calculations for subsequent iterations. A computer with a central processing unit (CPU) has fewer cores, greater memory, and slower memory access than a graphics processing unit (GPU).¹ The GPU allows the iterations of the loop to run simultaneously when the separate iterations are independent. Maintenance of the results' accuracy and shortening of the calculation run-time are the desired performance improvements.

In order to compare the CPU and GPU, we calculated partial derivatives of displacement and strain² induced by unit slip on triangular elements on the CPU and altered the code using a GPU enabling platform called Jacket. This allowed comparison between an eight processor CPU to 112 and 480 processor GPUs. Jacket requires changes to the CPU code, including renaming built-in MATLAB functions³ and the replacement of certain CPU functions that are unsupported by Jacket. MATLAB's standard execution is on the CPU, therefore, MATLAB must be told when to move variables and functions onto the GPU. We tested the code run-times with different variables initially sent to the GPU, to see effects of overhead data transfer time from the CPU to GPU. When the GPU ran out of memory, the code was altered to move the solutions from the GPU back to the CPU to free GPU memory.

By troubleshooting the programs, we were able to successfully rewrite the code originally intended to run on the CPU for the GPU. Figure 1 shows the run-time relationship between the displacement and strain calculations on the CPU and GPU for varying numbers of triangles (loop iterations). Strain, a more complicated calculation, has a greater speed advantage than displacement. The graph also shows that speedup of both codes increases with the number of triangles in the mesh. We found that, while running calculations using single precision (fewer decimal places) was quicker, the error was greater than the results from double precision calculations.

Because of the inaccuracy of single precision, we conclude that it is desirable to use double precision on the CPU or the double precision enabled graphics card. For a smaller number of triangles, the advantage of using the GPU is negligible; however realistically, processing enough data to accurately represent geological processes will require the GPU. (Supported by Jack Loveless Startup Fund)

Advisor: Jack Loveless

References:

¹Larsen, Torben. 2011. Parallel High Performance Computing With Emphasis on Jacket Based GPU Computing. Aalborg University. 4-71.

²Meade, BJ. 2007. Algorithms for the Calculation of Exact Displacements, Strains, and Stresses for Triangular Dislocation Elements in a Uniform Elastic Half Space. *Computers & Geosciences* 33.8: 1064-1075.

³AccelerEyes LLC. 2012. Jacket Wiki. <http://wiki.accelereyes.com>, August 2012.

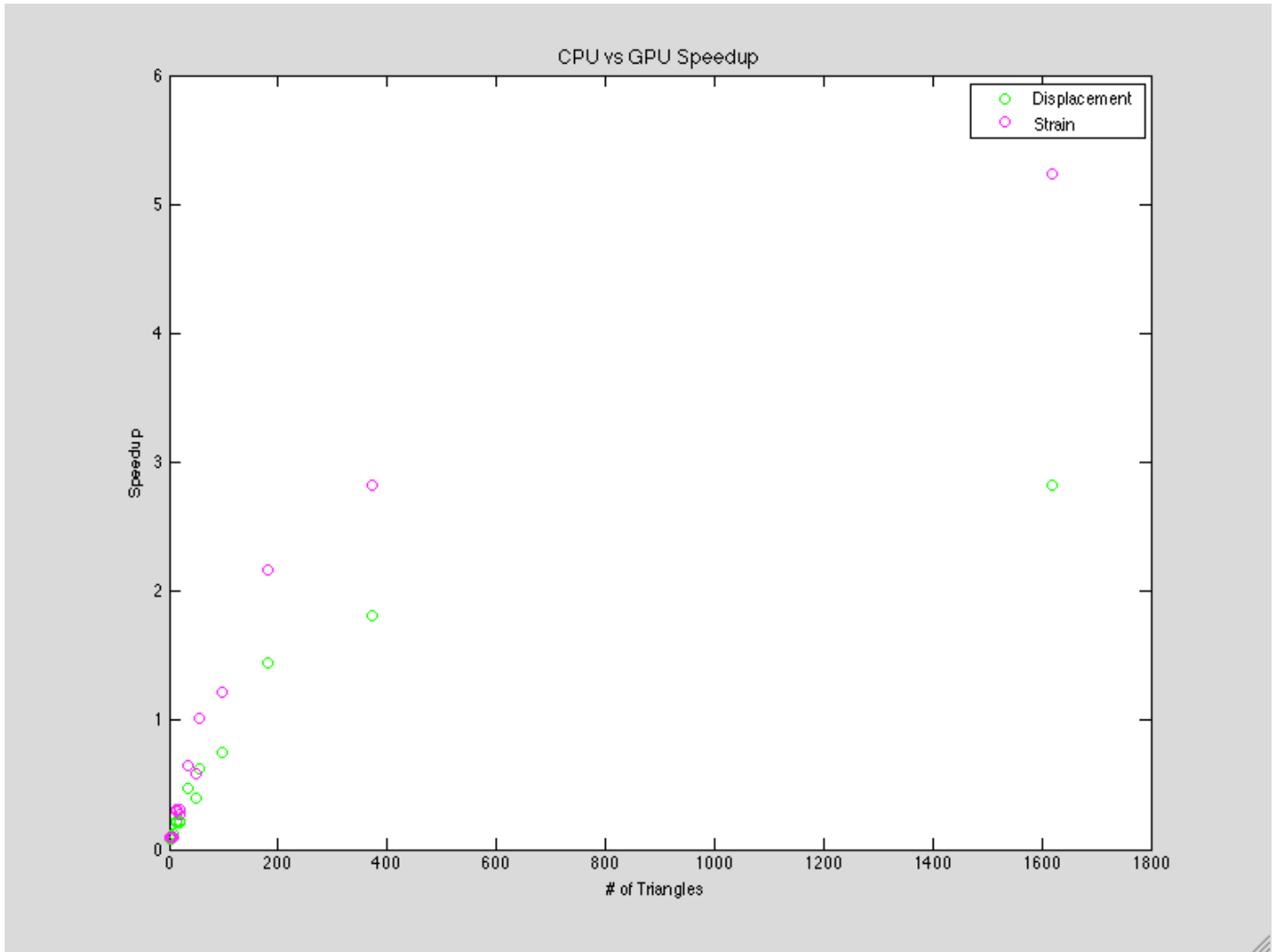

Revisiting the Slip Distribution of the 1994 Northridge, California Earthquake

Bismita Sahu

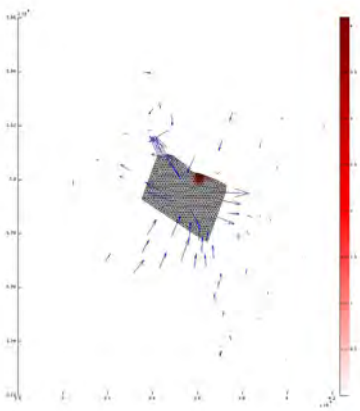

In this project, GPS data was used to calculate the fault slip distribution on the faults which could potentially have caused the 1994 Northridge earthquake in southern California. The moment of the earthquake was given as a function of the elasticity of the earth's crust, the fault's area and the slip magnitudes thus calculated. A variety of tools including singular value decomposition and weighted least squares were employed to come upon the desired results. The adjacent figure shows the pattern of slip on the fault which caused the Northridge earthquake.

The problem to be solved is an undetermined least square problem because there are precisely 66 GPS stations and more than 500 GPS stations are required to provide a solution for the realistic geometry of the fault. This can be mathematically expressed as $3 \times n > 2 \times m$ where m and n stand for slips on the faults and GPS stations respectively. At each GPS station, there are three components of displacement measured (north, east, and up), and on each element representing the fault, two components of slip are estimated, one in the strike direction, and one in the dip direction. To make the problem evenly determined we include a minimum curvature (smoothing) constraint on the slip distribution and we are posed with the challenge of determining the best weighing value of real and smoothing constraints. The elastic partial derivatives relating the strike and dip components slip on the triangular elements in the fault to displacement at the GPS stations are calculated and used in the inversion of GPS observations to estimate the earthquake slip distribution. The slip distribution is then used to calculate the moment magnitude of the earthquake.

The results of this project indicated that carrying out the inversions with a non-negative least squares estimator gives the closest estimates to the GPS displacements. A reasonable slip magnitude range of 0.5-4.5m with the median slip magnitude being 2.5m is obtained which agrees with prior results (Hudnut et al). However the moment magnitude is higher than expected.

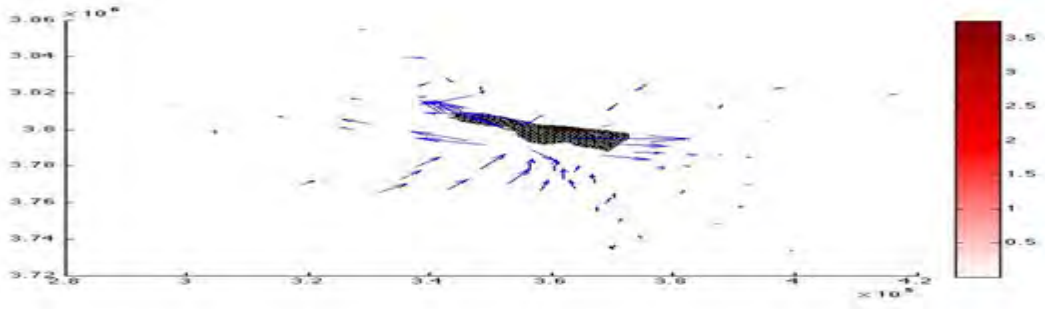

In the above figure the truncation value was set at 7.5×10^{-3} m which gives $M=7.08$ (moment magnitude) and a median slip magnitude of 2m. This shows that there is a trade-off between the best fit slip magnitude and the best fit moment magnitude ($M=6.7$) of the earthquake. (Supported by the Jack Loveless Startup Fund)

Advisor: Jack Loveless

Constraining the Record of Neoproterozoic Life: New Insights from Neoproterozoic Strata of Northern Namibia

Maggie Sawdy

Global events and anomalies throughout time have been recorded in the geologic record and have shaped the evolution of life on earth. During the Cryogenian period (750-635 Ma), unusual, low latitude glacial deposits capped by carbonates appeared twice (Hoffman et al., 1998). The snowball earth hypothesis suggests that the earth experienced extremely cold periods followed by rapid warming (Hoffman et al., 1998). The severity and extent of the glaciers is debated, but the rapid climatic changes are undisputed and would have had dramatic consequences for the diversity and ecology of organisms.

The Otavi Group of northern Namibia spans both Snowball earth events. The Beesvlakte Formation (Tonian) and Okakuyu Formation (Cryogenian) are pre-Sturtian glacial age while the Rasthof Formation (Cryogenian) and Ombaatjie Formation (Ediacaran) are post-Sturtian glacial age. Recent work on the Okakuyu Formation has yielded possible sponge-like microfossils dated at ca. 760 my old (Brain et al., 2012). Also diverse and abundant microfossil assemblages have previously been found in the microbialaminates of the Rasthof Formation (Pruss et al., 2010; Bosak et al., 2011a). The assemblages included testate microfossils and possible foraminifera (Bosak et al., 2011b). At different localities, differences in ecological diversity have been observed (Bosak et al., 2011a, Dalton et al., in review). The presence of microfossil assemblages shows that eukaryotes and their ecological communities were present immediately after the first glaciation in the Snowball earth event. Furthermore, sponge-like microfossils have been found in the Ombaatjie Formation similar to the microfossils in the Okakuyu Formation (Brain et al., 2012). This suggests that similar organisms were present before and after the glaciation.

In my work, thirty-seven samples from across the four formations were examined. One set of samples from the Beesvlakte Formation (Beesvlakte), one set of samples from the Okakuyu Formation (Otjize), five sets of samples from the Rasthof Formation (Okakuyu, Heuwels, Otjomatema, Okatjovandu, and Okaaru), and two sets of samples from the Ombaatjie Formation (Heuwels and Danube) were examined. Except for the Rasthof Formation at Okaaru, none of the localities had previously been examined for microfossils. The samples were all dissolved in 10% acetic acid buffered with 10% ammonium acetate. Residues were collected using suction filtration at $>100\mu\text{m}$ and $41-100\mu\text{m}$. Microfossils were extracted from the residues under a dissecting scope and examined in more detail under the SEM.

Every locality except for Otjize yielded microfossils, and at least nineteen residues have been categorized as fossiliferous. The fossiliferous material included testate microfossils and unidentified organic material. The presence of microfossils in the three formations further illustrates that eukaryotes and their resulting ecological communities were present both before and immediately after the Sturtian glacier despite the dramatic climatic changes. Further work on the biological affinities of these organisms will help constrain the role of climate change in influencing diversity during this critical yet understudied period of evolution. In summary, my work is helping to fill in gaps in the fossil record while adding to the understanding of the snowball earth events and hypothesis. (Supported by the Schultz Foundation)

Advisor Sara Pruss

References:

- Bosak, T., Lahr, D.J.G., Pruss, S.B., Macdonald, F.A., Dalton, L., & Matys, E., 2011a. Agglutinated tests in post-Sturtian cap carbonates of Namibia and Mongolia. *Earth Planet. Sci. Lett.* 308(1), 29-40.
- Bosak, T., Lahr, D.J.G., Pruss, S.B., Macdonald, F.A., Gooday, A.J., Dalton, L., & Matys, E., 2011b. Possible early foraminiferans in post-Sturtian cap carbonates. *Geology*, 40(1), 67-70.
- Brain, C.K., Prave, A.R., Hoffmann, K.H., Fallick, A.E., Botha, A., Herd, D.A., Sturrock, C., Young, I.,
- Condon, D.J., & Allison, S.G., 2012. The first animals: ca. 760-million-year-old sponge-like fossils from Namibia. *S. Afr. J. Sci.* 108(1/2).
- Dalton, L. A., Bosak, T., Macdonald, F. A., Lahr, D. J. G., and Pruss, S. B., in review at *Palaio*, Preservation and morphological variability of assemblages of agglutinated eukaryotes in Cryogenian cap carbonates of northern Namibia, 43 pp.
- Hoffman, P.F., Kaufman, A.J., Halverson, G.P., & Schrag, D.P., 1998. A Neoproterozoic snowball Earth. *Science* 281(5381), 1342-1346.
- Pruss, S.B., Bosak, T., Macdonald, F.A., McLane, M., & Hoffman, P.F., 2010. Microbial facies in a Sturtian cap carbonate, the Rasthof Formation, Otavi Group, northern Namibia. *Precambrian Research* 181, 187-198.

Comparison of Nutrient Cycling in Secondary and Mature Deciduous Forest

Theo Sweezy

This study examines the impact of forest succession, induced by invasive species, on soil chemistry. The hemlock woolly adelgid (*Adelges tsugae*, HWA) is causing the decline of eastern hemlock trees (*Tsuga canadensis*) in the northeast. To ascertain the effect of this decline on soil nutrient cycling, we compared soil chemistry between a mature hemlock stand and a black birch stand - a regrowth of hemlock trees logged twenty years ago. We were interested to know if differences in soil chemistry between hemlock and black birch growth were representative of long-term or short-term differences resulting from forest disturbance. Therefore, this years study included analysis of soil chemistry beneath black birch trees in a nearby mature hardwood forest.

Concentrations of ammonium and nitrate were measured by ion chromatography after preparing extract solutions by mixing soil with 0.02M strontium chloride. Concentrations of exchangeable base cations (Mg, Ca, Na, K) were measured on the ICP with soil extract solutions prepared with 1M ammonium chloride. Exchangeable acid cations, Al and H, were measured on extracts, prepared with 1M KCl, by titrations of NaOH and HCl and using a phenolphthalein color indicator. Results were normalized by soil weight and corrected for soil moisture.

In a general summary of our findings, the mature black birch mineral horizon, similar to young black birch soils, has more aluminum and hydrogen than base cations. However, the mature black birch organic horizon had a base saturation of 58.8%, which is significantly higher than the 29% base saturation in young black birch organic horizon.

We measured large nitrogen mineralization rates in mature black birch organic horizons for both incubation periods (May 21-June 19 and June 26 - July 23; total nitrogen= 7.0 mg N/kg soil*days; nitrification=3.8 mg N/kg soil*days). Nitrogen mineralization and nitrification rates in the young black birch organic horizons for the May-June incubation period (3.3 and 0.1 mg N/kg soil*days, respectively) were lower compared to mature black birch rates, but are high relative to young black birch data from data from the summer of 2011.

Findings indicate that the soil chemistry of the young black birch plot does not resemble that of the mature deciduous forest. Differences in soil chemistry might be explained by the young black birches' logging history, but geographic and physical differences (eg. the mature black birch is on a slope and soils drier) could also effect soil chemistry. We anticipate differences due to location and soil moisture would be small. (Supported by the S. D. Bechtel Fund)

Advisor: Amy Rhodes

Lab Analysis of Samples Collected from Early Triassic Moenkopi Formation Carbonates in Nevada

Sophie Westacott



The Early Triassic is a period of slow recovery following the most massive extinction event in Earth's history.¹ Studying the fossil record from this time provides insight into what characterized that recovery in terms of diversity, abundance, body size, and other factors, which in turn reveal what the environmental conditions were like. The focus of my project was the lab analysis of samples I collected in the field this past January from the Virgin Limestone Member of the Moenkopi Formation at two localities in the southern Nevada Muddy Mountains where silicified fossils are present.

Identifying and determining abundance of microscopic fossils while they remain trapped in rock is difficult if not impossible. One solution to this problem, if the fossils are silicified, is to dissolve away the carbonate matrix in acid, freeing the fossils and isolating them in the undissolved residue. This method is particularly useful for identification, as the entire 3-dimensional fossil can be examined from every angle and under different microscopies, including the SEM. The residue can also be quickly separated according to size using sieves. A drawback is that unsilicified or less well-preserved fossils will be underrepresented.

To balance that bias, a second method was used in conjunction with the first. Thin sections, very thin rock glued to a microscope slide, were made from each sample using rock saws, polishing wheels and other equipment. When these are viewed under a petrographic microscope, both silicified and non-silicified fossils can be identified along with other material. Point-counting, which entails identifying the material directly under the cross-hairs at 200 evenly spaced points on the slide, gives quantitative data on the relative abundance of everything in the sample, from bivalves to carbonate cement.²

The localities these samples come from are known to have formed during the early Triassic, but more precise ages can help to contextualize them beside other scientists' work. Small, superficial holes were drilled into a cut slab of each rock sample, and the powder created by the drilling was collected in test tubes (process depicted in accompanying photos). The tubes have been sent away for testing, and the result will be a carbon isotope profile that can be matched against a profile with known ages.

I will continue this project during the academic year as an honors thesis, the ultimate goal of which is to compile data using the methods described above to form an idea of what was happening at these localities during the early Triassic, and in doing so contribute to our knowledge of this unique period of recovery. (Supported by the Schultz Foundation)

Advisor: Sara Pruss

References:

- ¹Pruss, S. B., and Bottjer, D. J., 2004, Early Triassic Trace Fossils of the Western United States and their Implications for Prolonged Environmental Stress from the End-Permian Mass Extinction, *Palaios*, v. 19, p. 551-564.
- ²Payne, J.L., Lehrman, D.J., Wei, J., and Knoll, A.H., 2006, The pattern and timing of biotic recovery from the end-Permian extinction on the Great Bank of Guizhou, Ghizhou Province, China, *Palaios*, v. 21, p. 63-85.

Early Research in Science, Technology, Engineering and Mathematics at Smith College

Kate Aloisio

How do early Science, Technology, Engineering and Mathematics (STEM) research programs impact academic outcomes in the STEM fields? This summer we investigated this question with the Office of Institutional Research at Smith College. Smith works to create more opportunities for undergraduate research in many academic fields including the STEM fields. Smith College is a leading institution for offering early research opportunities (research conducted in the first two years of college); one particular program, the primary focus for this research, is the Achieving Excellence in Mathematics, Engineering and Sciences program (AEMES).

AEMES, introduced in 2007, is a Smith program dedicated to building a community of diverse students in the sciences, math and engineering who engage in early research with one-on-one faculty mentoring and peer mentoring¹. The first cohort included fifteen students who are members of groups traditionally underrepresented in the sciences including students of color and first-generation college students (for whom neither parent earned a bachelor's degree) and indicated that they planned to major in science, math or engineering. Since then each year approximately twenty first-year students who indicate that they are interested in science are invited to join this early research opportunity. At the time of this analysis, there are three active cohorts and two graduated cohorts.

We are interested in the characteristics of these cohorts and the program's impact on the students' academic path through Smith. We first observed these students participation, perseverance, and achievement in science gateway courses. We also explored these students' later Smith careers. Specifically, we investigated if they became natural science majors and whether they participated in independent research projects including Science Departmental Honors, Science Special Studies, and SURF. Once we developed data structures optimized for analysis representing a history of these AEMES scholars, culled from institutional and survey data sources, we wanted to explore the propensity of all Smith students interested in science to participate in STEM gateway courses, STEM majors, and STEM honors research compared to students in AEMES. To model these relationships we used linear and logistic regression models. The analyses for this project were conducted using SPSS. (Supported by the Susan M. Rambo Fund in Mathematics)

Advisors: Minh Ly, Cate Rowen and Nicholas Horton

References:

¹<http://www.science.smith.edu/mentoring/programs.html>.

<http://www.science.smith.edu/mentoring/programs.html>

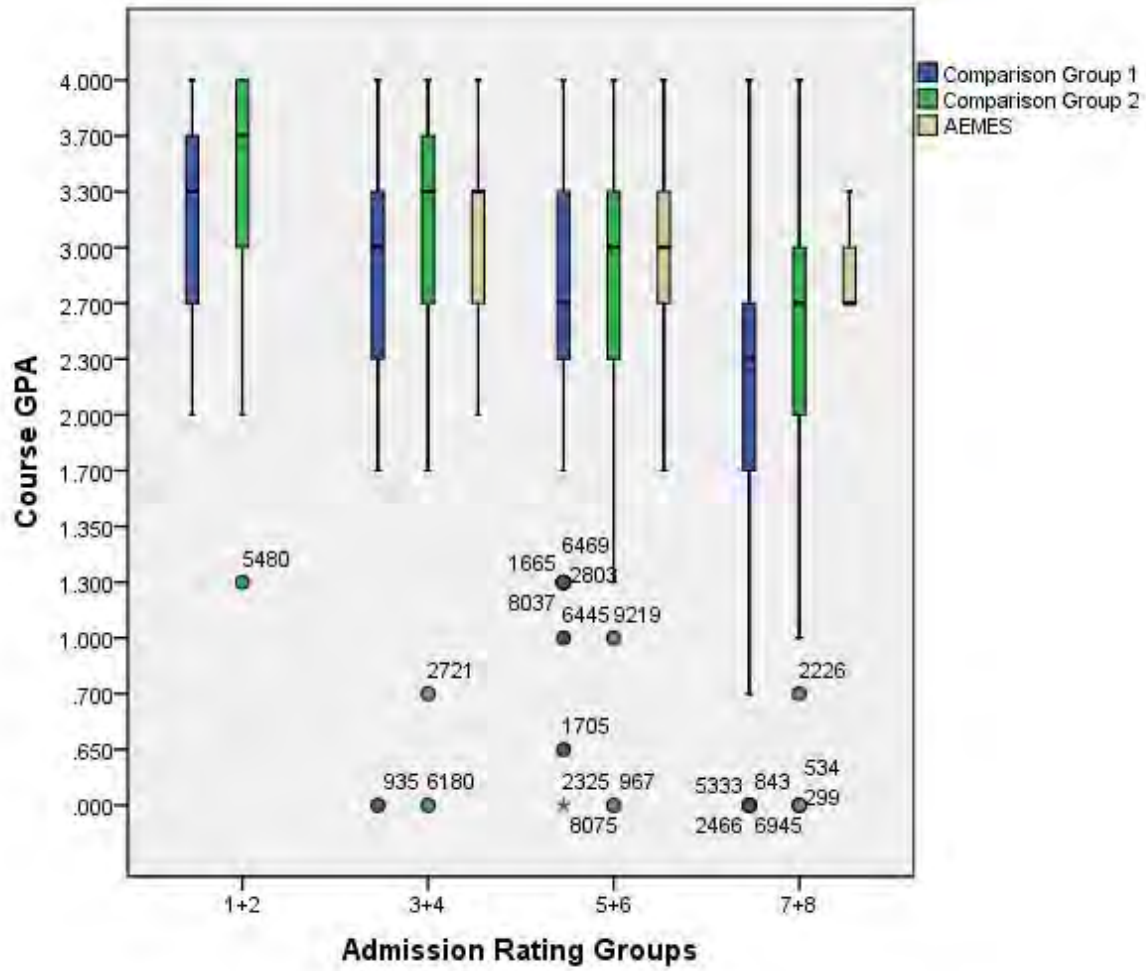

The Statistical Sleuth in R

Ruobing Zhang

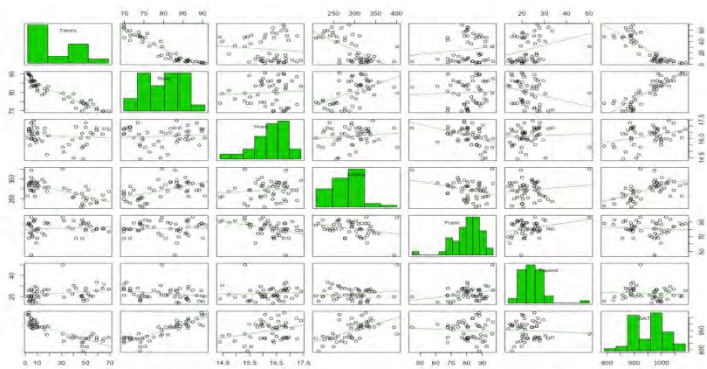

Are there ways to simplify the use of R code for teaching introductory statistics courses? For my SURF project, I collaborated with another SURF student, Kate Aloisio. We created a series of files (tools to showing how to undertake analyses) introduced as case studies in the *Statistical Sleuth: A Course in Methods of Data Analysis* (2002, Second Edition), the widely used textbook by Fred Ramsey and Dan Schafer.

The project was overseen by Professor Nicholas Horton, who is interested in improving statistical education. From his previous teaching experience, he found that students who take introductory statistics courses often find that the code is hard for them to understand and apply. We produced the documents using R and RStudio, an open source environment for statistical computing. We relied heavily on the knitr and mosaic packages. Knitr is an elegant, flexible and fast dynamic report generation tool. We used knitr to facilitate reproducible analysis of our R code and generate pdf output. The mosaic package was developed as part of the Project MOSAIC, an NSF-funded initiative to improve the teaching of statistics, calculus, science and computing in the undergraduate curriculum. This summer project was initially quite challenging. Before this project, I just wanted to get my code run successfully instead of paying attention to the clarity of presentation. But this project required me to keep the code straightforward and simple. During these three months, I gained a lot of practical experience about R coding and realized the importance of simplifying code for teaching purpose.

The pdf and knitr files are available online and can be downloaded from the site <http://www.math.smith.edu/~nhorton/sleuth/>. (Supported by the Susan M. Rambo Fund in Mathematics)

Advisor: Nicholas Horton

References:

Project MOSAIC: Modeling, Statistics, Calculus, and Computation. Project MOSAIC. Web. 5 Sep. 2012.
 Ramsey, F.L. and Schafer, D.W. 2002. *The Statistical Sleuth: A Course in Methods of Data Analysis*. California: Duxbury/Thomson Learning, 2002. Print.
 Xie, Yihui. *Knitr: Elegant, flexible and fast dynamic report generation with R*. n.p. Web. 5 Sep. 2012.

The Effects of Flavonoids on GABA_A Receptor Modulation via Patch-Clamping Electrophysiology and Tadpole Assays

Salma Bargach

γ -Aminobutyric acid, or GABA, is an amino acid neurotransmitter in the central nervous system. Known as the most prominent inhibitory neurotransmitter, its effects counteract those of excitatory pathways preventing seizures or death by excitotoxicity.

GABA_A receptors, a type of GABA receptor, are ligand-gated ion channels that consist of five subunits. When GABA binds to one of the GABA_A receptor subunits, a chloride ion channel opens creating an influx of chloride ions, making the cell more negative. Each subunit has a unique composition that corresponds to certain pharmacological properties. One of the subunits, the γ -subunit, has a benzodiazepine-binding site. Benzodiazepines are allosteric modulators of GABA_A receptors, which increase the frequency at which the chloride channel opens. The effects produced by benzodiazepines are counteracted by flumazenil, benzodiazepines' competitive antagonist.

Flavonoids are a polyphenolic compound found in plants, fruits, and vegetables. They are compounds categorized by their chemical structure, for instance, flavones, flavonoids, flavonols, and others. Some flavonoids can either act as flumazenil sensitive benzodiazepines or flumazenil insensitive benzodiazepines, resulting in negative or positive modulation of GABA receptor currents. Also their lipophilic characteristic gives them the ability to cross the blood brain barrier and reduce both oxidative stress and damage from free radicals, an action that has been suggested to reduce and prevent neurodegenerative diseases.

Patch clamp electrophysiology is an electrophysiology technique that allows for the recording from a single ion channel or whole cell currents. The specific patch clamp technique used was the whole-cell patch clamp. In this technique, a recording electrode forms a gigaOhm seal on the cell's membrane. Negative pressure is then used to break through the membrane allowing for the recording of all the receptors on the cell (hence 'whole cell'). The cell is held at -50 mV and, when superfused with GABA, this opens the chloride ion channel and chloride ions flow out of the cell. This net flow of chloride ions is recorded as a current in picoamps. Different drugs can either positively or negatively modulate this current. Recordings showing a positive modulation are identified by increased chloride current via GABA_A receptors expressed in HEK (human embryonic kidney) cells.

In the following study, flavonoid-induced modulation of GABA currents was investigated in human embryonic kidney (HEK) cells that have been stably transfected with $\alpha_1\beta_3\gamma_2$ GABA_A receptors. Using patch clamp electrophysiology, this project focused on flavonoids that have been suggested to be positive modulators of GABA currents. The flavonoids used were baicalien, catechin hydrate, and naringenin. Each compound was co-applied with a constant GABA concentration, which also acted as a control, to see if any of the compounds would positively enhance the GABA currents (suggesting a possible anesthetic/sedative effect of the flavonoid). Alongside the electrophysiology, tadpole sedation/anesthesia assays were run for all three flavonoids and compared to propofol, a known anesthetic. Tadpoles were used as the animal model because the concentrations used to anesthetise tadpoles has been shown to be similar to mammalian levels. In the tadpole assay, both baicalien and naringenin acted as an anesthetic at very high concentrations. (>300 μ M) Catechin hydrate had no anesthetic effects. The electrophysiology data confirmed that none of the compounds tested were positive modulators of GABA_A receptors.

Although these three compounds did not enhance the GABA response, natural compounds are still of interest in neuropharmacology. As a result, in future experiments I hope to pursue natural compounds that have a higher probability of binding to the benzodiazepine site on the GABA_A receptor in the search for new sedative or anesthetic compounds. (Supported by the Howard Hughes Medical Institute)

Advisor: Adam Hall

Patch-Clamp Investigation of the Modulation of GABA_A Receptor Currents with Isomers of the Potential Anesthetic 2,6-dimethylcyclohexanol

Luvana Chowdhury

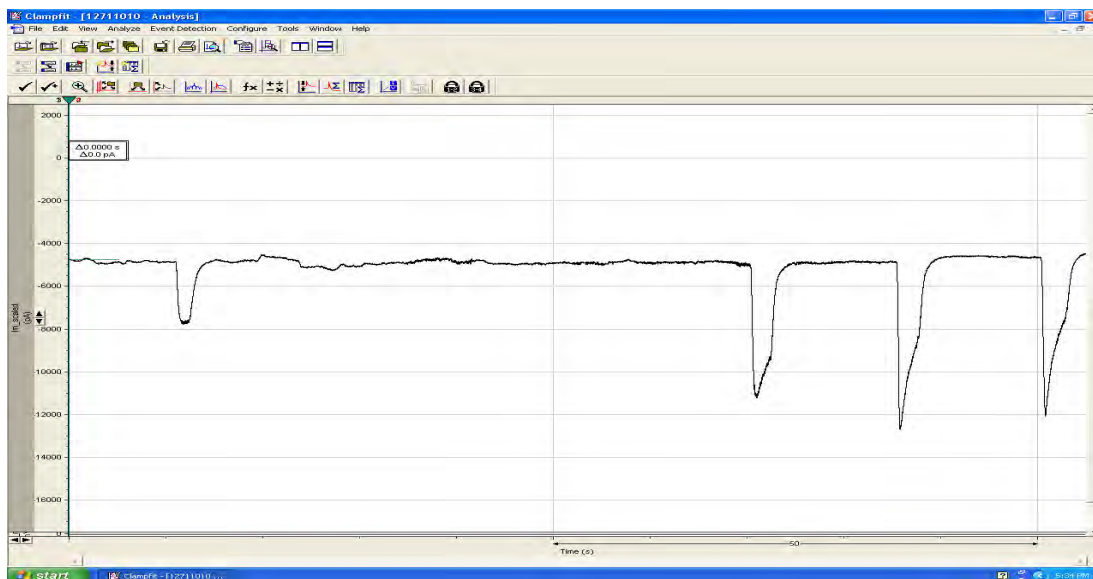

Anesthetic compounds are used clinically to produce a loss of sensation, including pain, during invasive procedures. Anesthetic compounds bind to ligand-gated, GABA_A receptors and increase inhibitory transmission, or positively modulate the GABA_A receptor. Many anesthetic compounds consist of isomers. Although commonly used surgical anesthetic such as isoflurane is not separated for clinical use, understanding stereoselectivity and chirality are critical to achieving a desired anesthetic effect in patients.² A recent study showed positive modulation of the GABA_A receptor using 2,6 dimethylcyclohexanol.¹ However, the anesthetic potential of individual isomers of 2,6 dimethylcyclohexanol has not been fully studied previously. In this patch-clamp investigation, modulation of GABA_A receptor currents with isomers of the potential anesthetic 2,6-dimethylcyclohexanol were measured. With increasing 2,6-dimethylcyclohexanol racemic mixture concentrations (1-300uM) co-applied with 3uM GABA, positive modulation of GABA_A receptor currents was observed at higher doses (30, 100, 300uM) compared to currents evoked by 3uM GABA alone. The application of 3uM GABA co-applied with *trans,trans* 2,6-dimethylcyclohexanol resulted in an enhancement in the receptor currents compared to the 3uM GABA control, while *cis,trans* 2,6-dimethylcyclohexanol isomer co-applied with 3uM GABA had no effect on the receptor modulation. Lastly, 30uM of *trans,trans* isomer positively modulated the GABA dose response. The overall positive modulation of *trans,trans* demonstrated the highest anesthetic potency and effectiveness compared to the racemic mixture and the other isomers. (Supported by the National Science Foundation)

Advisor: Adam Hall

References:

- Hall, A. C., Griffith, T. N., Tsikolia, M., Kotey, F. O., Gill, N., Humbert, D. J., Watt, E. E., Yermolina, Y. A., Goel, S., El-Ghendy, B., & Hall, C. D. 2011. Cyclohexanol analogues are positive modulators of GABA_A receptor currents and act as general anaesthetics *in vivo*. *European Journal of Pharmacology*, 667(1-3), 175-81.
- Burke, D. and D.J. Henderson. 2002. Chirality: a blueprint for the future, *British Journal of Anaesthesia* 88: 563-576.

Effects of Anxiety on Non-sexual Affiliative Behavior in *M. pennsylvanicus*

Ellen Gunzel

.....

During the summer we conducted tests on *microtus pennsylvanicus*, which aim to examine the role of anxiety in the expression of pro-social behavior and partner preference formation. One hypothesis regarding the role of oxytocin in pro-social interactions is that it functions to reduce social anxiety. This is consistent with our current understanding of meadow vole social behavior and its non-reliance on nucleus accumbens dopamine and reward signaling.¹ However, no specific tests, which relate anxiety behavior and social behavior, have been conducted. We plan to characterize base-line anxiety measures together with social behavior in voles housed in day lengths that promote social behavior (short day lengths; SDs) and voles housed in summer-like day lengths (long days; LDs) when voles are markedly less social.

Adding diazepam, at different dosages, will allow for the isolation of the effects of anxiety during the partner preference tests. By comparing how social behavior is altered by diazepam administration (versus saline control), the role of anxiety in social behavior will be clarified. "Diazepam will be administered during three behavioral tests of anxiety as well, in order to confirm its effectiveness in voles."

This study aims to determine the relationships between day length (10h vs 14h), anxiety (measured by light/dark box, elevated plus maze, and open field tests), and social behavior (measured by huddling time in partner preference tests), with a focus on same-sex affiliative behavior. Comparison between groups of long-day and short-day photoperiods will determine if anxiety differs among different seasons. It is expected that partner preference is more likely to develop with a co-housed female during the non-breeding season (SD condition). Individual differences in social contact during partner preference test and results from anxiety tests (open field, elevated plus maze, light/dark box) will be examined to determine if anxiety is related to sociality on an individual basis. (Supported by the Schultz Foundation)

Advisor: Annaliese Beery

Vole grouping:

# voles (pairs)	Day length	Dosage
20-24 (10-12)	LD	Saline
20-24 (10-12)	LD	Dose 1
20-24 (10-12)	LD	Dose 2
20-24 (10-12)	SD	Saline
20-24 (10-12)	SD	Dose 1
20-24 (10-12)	SD	Dose 2

References:

¹ Beery AK, Zucker I (2010) Oxytocin and same-sex social behavior in female meadow voles. *Neurosci* 169: 665-673.

The Effects of Isoflurane Pre-conditioning on MTF-1 Translocation to the Nucleus in Neurons and Microglia *in vitro*

Amanda MacAvoy

.....

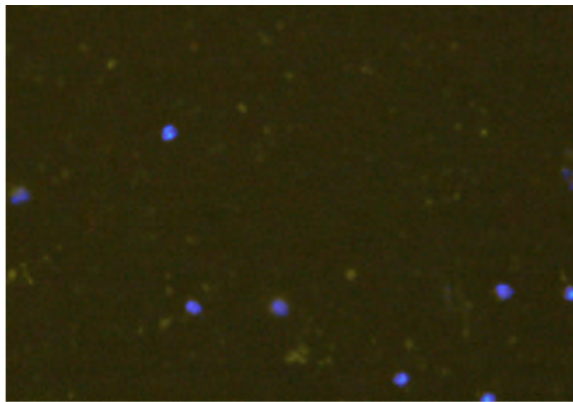

Fig 2. 129M WT culture. Following 2 hour Isoflurane exposure, MTF-1 is more localized to the nucleus; 48.4% nuclear translocation.

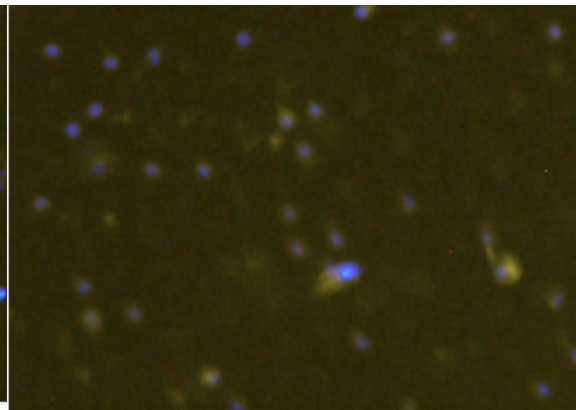

Fig 1. 129 M WT culture. Control shows diffuse cytoplasmic MTF-1 labeling with 20.7% nuclear translocation.

Anesthetic pre-conditioning involves the use of a clinical dose of anesthetic to protect against stroke. When isoflurane, an anesthetic, is administered *in vitro* prior to depriving neurons and glia of oxygen and glucose, the neurons and glia have a higher survival rate than if they are not administered the anesthetic. A proposed pathway for anesthetic preconditioning involves the release of nitric oxide intracellularly following the administration of an anesthetic. In this proposed pathway, the nitric oxide then causes metallothioneins, or metal-binding proteins, to release zinc into the cell, which causes the transcription factor MTF-1 to localize to the nucleus, which leads to the protective preconditioning effects.

This summer, I measured the cellular levels MTF-1 following isoflurane exposure in neurons. Both primary cultures of dissociated murine cortex and neuroblastoma cultures were exposed to the following conditions prior to MTF-1 staining: control (no exposure), two-hour ZnCl₂ (30mM and 100mM) exposure, two-hour isoflurane exposure (2.5%, 0.4 flow rate), and six-hour isoflurane exposure (2.5%, 0.4 flow rate). Fluorescent dyes were used to visualize MTF-1 translocation with confocal microscopy and spectrofluorimetry.

Preliminary results suggest that exposure to isoflurane triggers the translocation of the transcription factor MTF-1 to the nucleus. In 129 male WT cultures, a two-hour isoflurane exposure increased nuclear MTF-1 translocation 27.7% (Fig 2); a 6-hour isoflurane exposure resulted in a 17.2% increase in MTF-1 nuclear translocation. The results obtained from the neuroblastoma cultures were inconclusive. The data obtained using WT murine cultures look promising, however, more experiments will need to be carried out in order to obtain conclusive results. (Supported by the National Institutes of Health)

Advisor: Adam Hall

Isoflurane Impacts the Actin Cytoskeletal Signalling Pathway by Depleting Cofilin Reserves in Neonatal Murine Cortical Tissue

Belinda Nhundu and Shimu Liu

.....

General anesthetic toxicity is a major concern in obstetric, pediatric and geriatric medicine. In previous experiments carried in the Hall laboratory, we tested the neurotoxicity of both inhalant and intravenous general anesthetics on murine cortical neurons in primary dissociated culture. We discovered that the neonatal neurons were remarkably robust, suffering little degeneration at clinical concentrations and exposure lengths (Campbell *et al*, 2011).¹

However, when exposed to clinical concentrations of isoflurane and ketamine, extensive neurite retraction was observed. This result was supported by Turina *et al*. (2008)² who described how neurites of cultured rat cortical neurons retracted after exposure to the intravenous anesthetic, propofol, resulting in a retraction bulbs and thin trailing neurite remnants.

In an effort to quantify this retraction, we then developed culturing techniques for cortical neurons from postnatal mice (P0-P2) based on a culturing protocol described by Jana *et al*. (2007). This protocol largely removes glial cells resulting in a sparse plating of isolated neurons. We also utilized a largely homogeneous neuroblastoma cell line. Neurons were visualized on a confocal microscope using DIC, and time-lapse imaging was performed to monitor the changes resulting from volatile anesthetic exposures. General anesthetic solutions of 1, 2, and 5 MAC of sevo- and isoflurane were introduced (1 MAC, minimum alveolar concentration ~ the clinical concentration for maintaining a plane of anesthesia). Immediately (~5 min) after exposure we observed a decrease in overall cell motility and changes in cell morphology including thinning and shortening of neurites.

We hypothesized that a Rho-A signaling pathway may be responsible for the anesthetic-induced retraction process leading to cytoskeletal rearrangement (whereby \uparrow Rho-A activity \rightarrow \uparrow Rock \rightarrow \uparrow LIM Kinase-1 \rightarrow Phosphorylation of Cofilin). It has been reported that it may lead to actin polymerization/depolymerization and hence cytoskeletal reorganization.

Using Western blot analysis we measured the levels of phosphorylated and unphosphorylated cofilin in isoflurane-treated neuroblastoma. Samples of total protein were collected from differentiated neuroblastoma cell lines exposed to 2 MAC isoflurane for ten minutes and four hours. Western blot results showed a decrease in both phosphorylated and unphosphorylated cofilin. These results suggest that isoflurane has an impact on cell morphology and dynamics of immature brain cells through perturbation of molecular events governing cytoskeletal formation. In October we will be presenting our work at the Society for Neuroscience conference in New Orleans and continue this work as an honors project in the 2012-13 academic year. (Supported by the National Institutes of Health and the Blakeslee Fund in the Biological Sciences)

Advisor: Adam Hall

References:

¹L.Campbell, et.al. Assessment of general anaesthetic cytotoxicity in murine cortical neurones in dissociated culture. *Toxicology* 283(2011), pp.1-7 .

²D. Turina, V. M. Loitto, K. Björnström, T. Sundqvist, and C. Eintrei. Propofol causes neurite retraction in neurones *Br. J. Anaesth.* (2008) 101(3): 374-379. *first published online June 27, 2008 doi:10.1093/bja/aen185.*

Circadian Synchronization in Per2:Luc Transgenic Mice Hepatocyte Cultures

Lorna Pyle

The suprachiasmatic nucleus (SCN) of the anterior hypothalamus is known as the master pacemaker because of its control of the endogenous rhythms of the mammalian circadian clock. The SCN coordinates the molecular clocks within every cell in the body to maintain systemic synchronization. However, recent studies of the circadian rhythms of the liver counter this notion of complete neural control of the peripheral oscillators. For instance, abnormal meal times phase-shifted the biological rhythms of the liver without changing the rhythms of the SCN.¹ Additionally, in the absence of input from the SCN, the liver remains rhythmic.² Whereas cultured fibroblasts lose their rhythmicity in a matter of days, hepatocytes, the primary cells of the liver, retain robust rhythms *in vitro* for over 60 days.³ Our research aims to show that hepatocytes synchronize to express robust circadian rhythms without neural input in order to further understand the mechanism of circadian synchrony.

Hepatocytes are isolated from Period2: Luciferase (PER2:LUC) mice. In these transgenic mice, the expression of the clock gene PER2 produces bioluminescence.⁴ We capture the rhythmic bioluminescence of individual hepatocytes with a chilled CCD camera. Due to construction, this study is still in its early stages. We are still in the process of acquiring data. This data will then be quantified with MATLAB to determine the phase and period of each hepatocyte. We eventually will compare the rhythms of neighboring hepatocytes. Localized synchronization will indicate whether the circadian rhythms of the liver can remain synchronized through local communication and without the input from the SCN. (Supported by the National Science Foundation)

Advisor: Mary Harrington

References:

- ¹Damiola F, Minh NL, Preitner N, Kornmann B, Fleury-Olela F, Schibler U (2001) Restricted feeding uncouples circadian oscillators in peripheral tissues from the central pacemaker in the suprachiasmatic nucleus. *Genes & Dev* 14: 2950-2961.
- ²Pezuk P, Mohawk J, Yoshikawa T, Sellix M, Menaker M (2010) Circadian organization is governed by extra-SCN pacemakers. *J Biol Rhythms* 25: 432-441.
- ³Luitje M.E. 2011. Circadian rhythms and coupling in hepatocytes. Smith College Honors Thesis.
- ⁴Yoo S-H, Yamazaki S, Lowrey PL, Shimomura K, Ko CH, Buhr ED, Slepka SM, Hong H-K, Oh WJ, Yoo OJ, Menaker M and Takahashi JS (2004) PERIOD2:LUCIFERASE real-time reporting of circadian dynamics reveals persistent circadian oscillations in mouse peripheral tissues. *PNAS* 101:5339-5346.

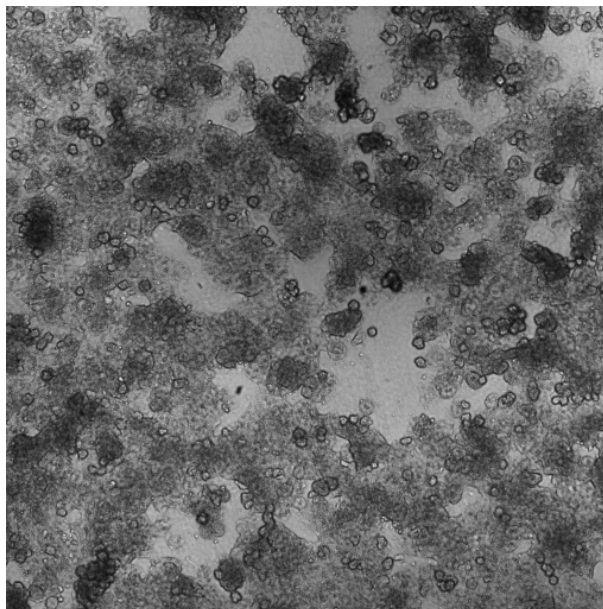

Isolated PER2:LUC hepatocytes
(Nikon Eclipse Ti-U, 10X objective;
taken with the iKon-M Andor camera)

Long-Term Fatigue Causes Morphological Changes in Microglia

Helen Queenan

It is important to understand where the most noticeable effects of fatigue are concentrated in the brain in order to find treatments for this disorder. One factor that has been closely related in helping to understand this disease more fully is the activation of microglia. Through inducing long-term fatigue in animals, either through exterior manipulation, such as drugs or through natural causes, or age, we can examine and pinpoint where or what effects activated microglia may cause. The purpose of our study was to determine differences between activated microglia in young and aged mice. It was also important to discover where in the brain activated microglia are most concentrated during fatigue. With this, we can target that area and in the future create a drug that specifically targets the microglia in that brain region. In order to accomplish this, a quantitative method needed to be tested and finalized. The experiments conducted in order to answer some of these concerns included running immunocytochemistry and obtaining a quantification method for the results from the immunocytochemistry. Female mice, young and aged, were euthanized. Their brains were removed and frozen on dry ice. The brains were sliced at 20 micrometer sections and sliced via a cryostat. Cryosections were then fixed and run through an immunocytochemistry protocol. At the end, sections were incubated in DAB, dehydrated, and ready for analyses. Pictures were obtained and analyzed by Image J. Image J was used as a way to compare brain regions, from a young and aged mouse, by quantifying the activated microglia in the brain regions. Results from our experiments suggest that there is a morphological change in activated microglia in mice experiencing long term fatigue, and a method found to effectively quantify microglia will prove effective when determining where, in which brain regions, activated microglia are most concentrated. Future research would observe the differences in Interlukin-1 treated young mice in addition to a difference between aged mice treated with Interlukin-1. (Supported by the Frances Baker Holmes Fund)

Advisor: Mary Harrington

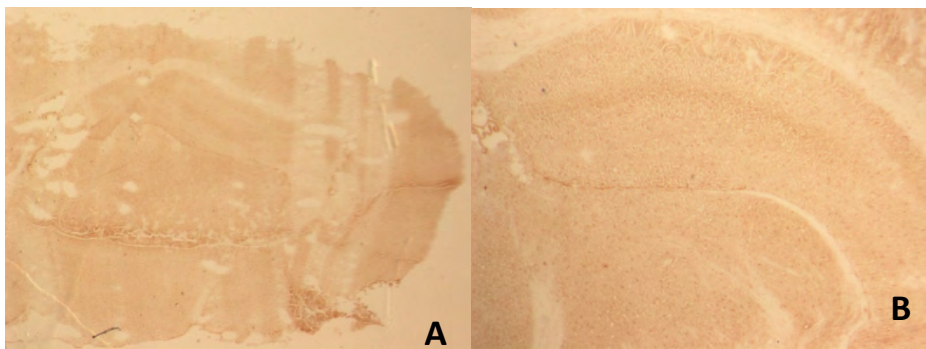

Figure 1: Hippocampus of (A) aged mouse (40X) and (B) young mouse (40X)

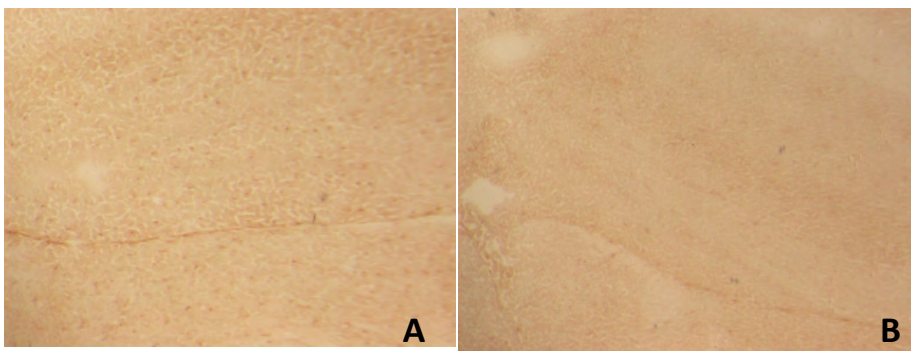

Figure 2: Hippocampus of (A) aged mouse (4X) and (B) young mouse (4X)

Neuroendocrinology of Sociality in Meadow Voles

Kara Reitz

.....



There is a lot of interest in the neurobiology of social behavior. However, little is understood about mechanisms supporting relationships between individuals who are not mates. In the summer months female meadow voles (*Microtus pennsylvanicus*) are reproductively receptive and are also extremely territorial and solitary. In the winter months voles are markedly more social and will exhibit more huddling behavior among their peers. The aim of this study was to examine the role of seasonal variation in anxiety in non-reproductive affiliative behaviors in meadow voles by reducing anxiety with diazepam and by manipulating day-length cycles.

Voles were reared in two different day lengths to simulate the light shifts in summer and winter months: long day (14 hours of light, 10 hours of dark) and short day (10 hours of light, 14 of dark). They were also assigned to three distinct drug treatment groups that included a high dose of diazepam, a low dose of diazepam, or saline. To examine anxious behavior three anxiety tests were given over a two-week period: the elevated plus-maze, light/dark box and open field tests. Following this sequence of anxiety tests a partner preference test was given to examine the social behavior of the voles. The partner preference test consists of three chambers: two tethered voles on each end of the apparatus and a free vole. The free vole was allowed to roam between the chambers over a three-hour period and the time spent huddling versus alone was then analyzed. In order to examine the effect of diazepam, it was administered before partner preference tests and the EPM.

Based on what is known about both the anxiety and social behavior of meadow voles, it is expected that short day voles will exhibit more social behavior in the partner preference tests and lower anxiety in other behavioral tests. Conversely, long day voles are expected to exhibit less social behavior in the partner preference tests and more anxiety in the other behavioral tests. Diazepam is expected to reduce anxiety behaviors in the EPM and may alter social behaviors in partner preference tests across one or both day lengths.

Thus far there has not been much research done on the formation of non-reproductive social relationships in mammals, and this study aims to characterize natural variation in anxiety as a mediator of social behavior. (Supported by the Frances Baker Holmes Fund)

Advisor: Annaliese Beery

References:

- Hendrie, C.A., Eliam, D., Weiss, S.M. 1997. Effects of diazepam and buspirone on the behaviour of wild voles (*Microtus socialis*) in two models of anxiety. *Pharmacol Biochem Behav* 58, 573-576.
- Ossenkopp, K.P., van Anders, S.M., Engeland, C.G., Kavaliers, M. 2005. Influence of photoperiod and sex on locomotor behavior of meadow voles (*Microtus pennsylvanicus*) in an automated light-dark 'anxiety' test. *Psychoneuroendocrinology* 30, 869-879.

Investigation of a Molecular Mechanism for Anesthetic Preconditioning

Alexis Ziemba

Anesthetic preconditioning (AP) is a potential treatment for patients undergoing procedures that are accompanied by a high risk for ischemic injury (e.g. perioperative stroke) and cannot be treated by anti-coagulants. AP is a phenomenon by which tissues are pre-treated with clinical concentrations of a general anesthetic; this minor insult results in the upregulation of cellular protective measures, which defend against greater insults such as ischemia. Our lab aims to discern the mechanisms by which this protection occurs. We have proposed that exposure to the general anesthetic, isoflurane, increases the level of the signaling molecule nitric oxide (NO)², with astrocytes being the major producer of NO¹. This triggers a downstream increase of free intracellular Zn²⁺ (Figure 1).⁵

To first confirm increases in NO following isoflurane exposure, isolated astrocytes were exposed to isoflurane in a dedicated anesthetic chamber. The level of NO was measured six hours later using the Griess Reaction, a chemical analysis test. No difference was seen in the level of NO following isoflurane exposure. As changes in the level of NO were shown to be time-dependent in the cell type, microglia, earlier time points will be tested in astrocytes.

To determine if there are increases in intracellular free Zn²⁺ post-isoflurane exposure, dissociated brain suspensions were incubated with a zinc-fluorescing dye, Zinpyr-1. The suspensions were then exposed to either isoflurane or NO generators, and the fluorescence was measured before and after using spectrophotometric techniques. Unfortunately, no conclusions could be made as both isoflurane and NO generators were demonstrated to affect Zinpyr-1 when no cells were present.

Further understanding of the mechanisms of AP could lead to more effective administration in a clinical setting. Future studies will involve the study of metallothioneins (MT), zinc-binding proteins, which have been shown to be involved in the protection.⁴ MT wild type and knock out co-culturing experiments will be done to determine which cell types are involved in MT-mediated protection.

This work was continued from an honors thesis and was presented at the Beckman Symposium. (Supported by the Arnold and Mabel Beckman Foundation)

Advisor: Adam Hall

References:

¹Bal-Price A and Brown GC (2001) *J Neurosci* 21:6480–6491.

²Baumane L, Dzintate M, Zvejniece L, Meirena D, Lauberte L, Sile V, Kalvinsh I, Sjakste N (2002) *Acta Anaesth Scand* 46: 378–383.

³Edmands SD (2009) Open Access Dissertations Paper 78:1-104.

⁴Edmands SD and Hall AC (2009) *Anesthesiology* 110:538–47.

⁵Stitt MS, Wasserloos KJ, Tang X, Liu X, Pitt BR, St. Croix CM (2005) *Vasc Pharmacol* 44:149-155.

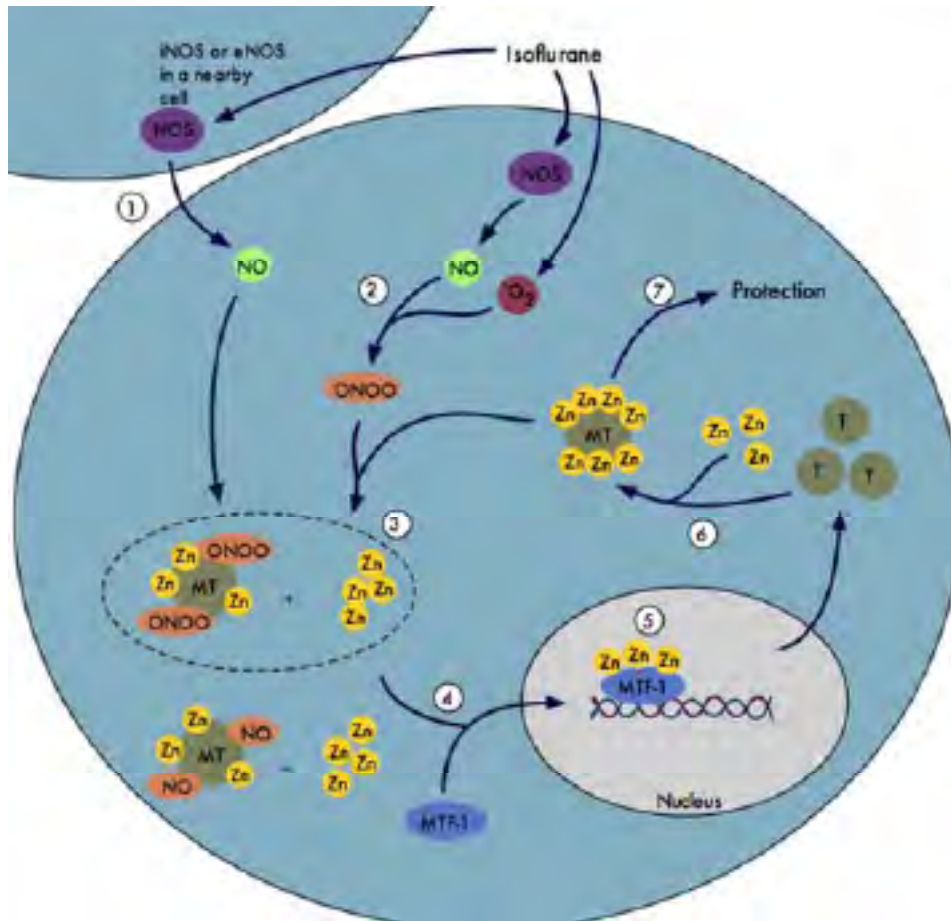

Figure 1: Proposed mechanism of anesthetic preconditioning³

Solar Collector

Rohini Ray and Ansha Zaman

With the emerging need for renewable energy, this project is aimed at designing an efficient water heater that utilizes the solar heat. The collector is based on the ideas of maximized contact with the solar ray, minimized loss through insulation and high heat storage capacity consists of a double walled acrylic cylinder within the inner cylinder runs a coiled copper tube (high heat capacity), through which the water will be passed. The transparent acrylic should prevent filtration of the solar rays, allowing a greater incidence of the waves on the copper coils, while also giving the collector durability. We also plan to improve our design by coating the copper coils, in the next set of collectors, with a partial absorber- black chrome which should enable the copper and hence the water to get hotter faster. The area surrounding the coil is to be filled either with a pressurized gas- He, CO₂, N₂ or vacuum. The vacuum filled chamber between the two cylinders insulates the unit by restricting heat loss through conduction and convection. Placing o-rings in end-cap grooves should also counteract heat loss from the system. We inserted a foam (that has a glass transition temperature of above 100 degrees Celsius) bed at the base to hold the copper tubing in place, which should also act as an additional source of insulation.

The commercially available solar heaters have losses in efficiency due to lack of direct contact between the medium that gets heated by the sun, and the water to be heated, and as they are rectangular, thereby reducing exposure to the sun's rays. Our design attempts to avoid these two inefficiencies.

During the testing process the different gasses will be filled into the collectors and a constant pressure will be maintained using the pressure gauges. The efficiency of the collector under each gas and vacuum will be recorded by measuring the temperature difference between the incoming water and the outgoing water. The gas with the highest change in temperature will then be used, and we can empirically analyze the productivity of this model vis-à-vis others. (Supported by the Schultz Foundation)

Advisor: Nathanael Fortune

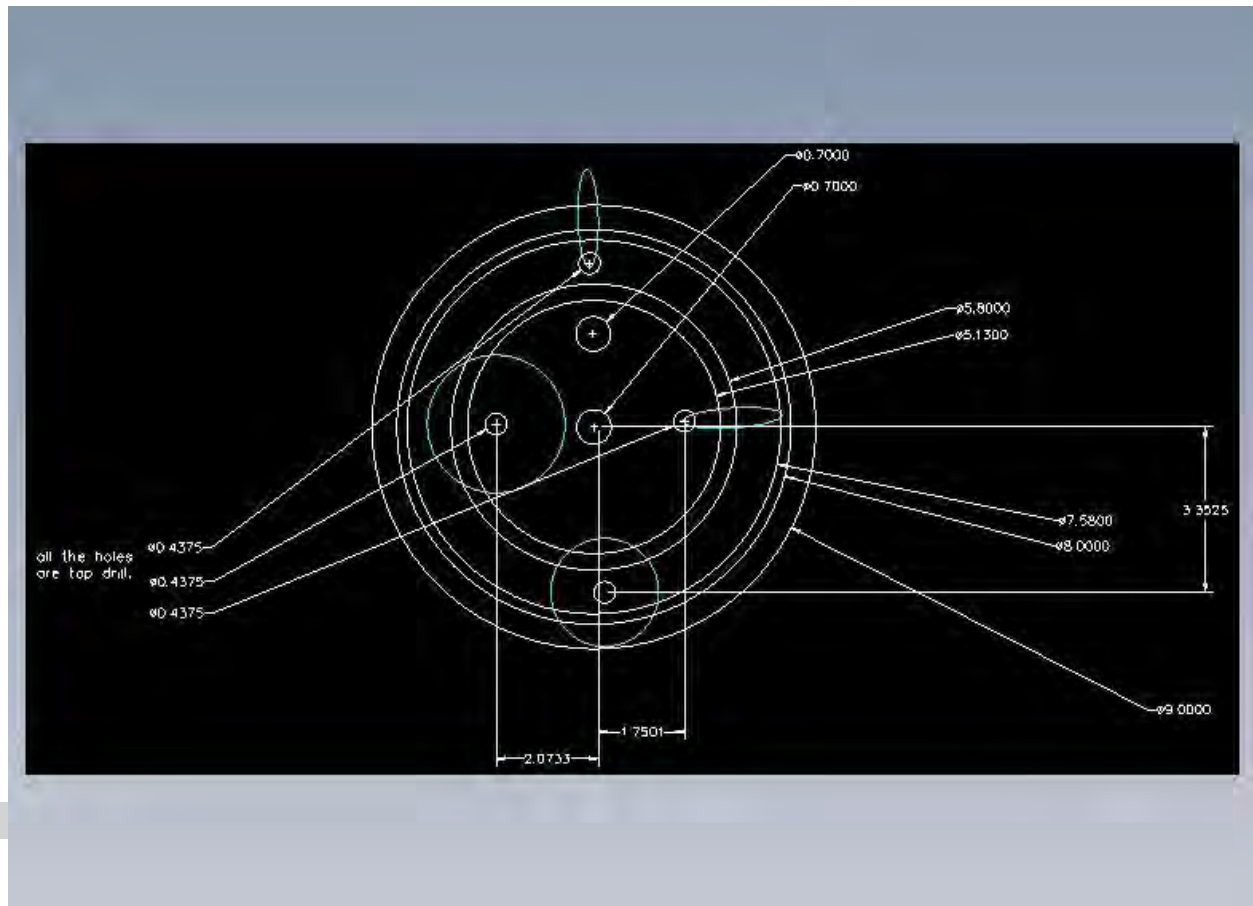

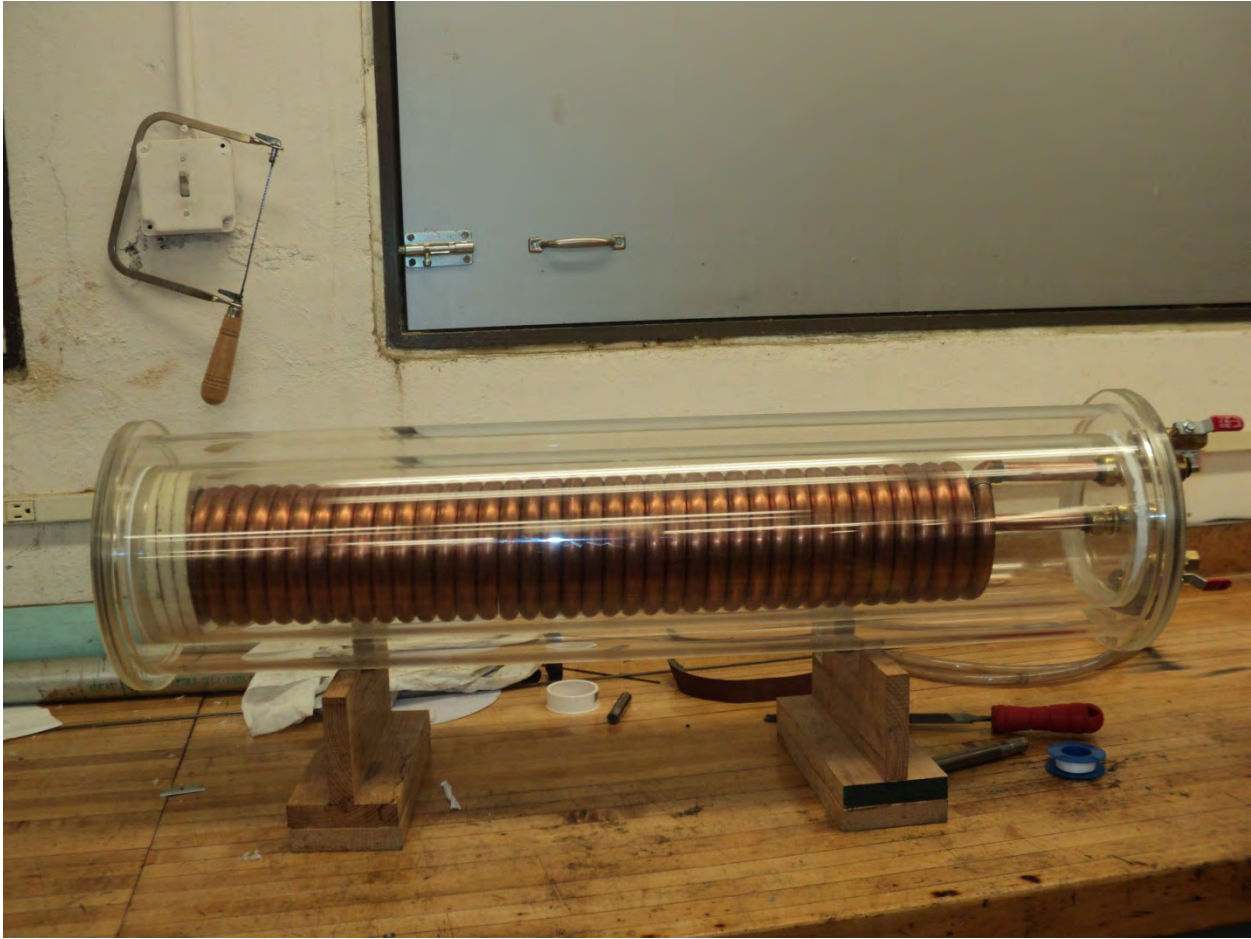

Telling Our Legacies Digitally (TOLD)

Aqdas Aftab

Personal narratives not only depict the state of one's psychology, but are also an important means of improving mental health and overcoming trauma and depression.¹ When exposed to the narratives of others, one can overcome isolation and the inability to address communal issues. To recognize the personal and communal troubles and needs of an underserved area, Smith College partnered with the North End Outreach Network (NEON) of Springfield, Massachusetts. Participating in digital storytelling workshops not only gave the residents of this area a means of purging their narratives, but also increased their computer literacy. Apart from making their digital stories, the participants filled out questionnaires evaluating their self-determination, vitality, computer skills and status in their community, before and after the workshops.

The digital narratives cover scores of themes such as displacement, mental disorders, trauma, death, health problems, racism, crime, poverty and violence. Yet most stories are laced with resilience and hope. The aim of my summer project was to archive these stories, organize the participants' data and analyze their stories for subject matter and health improvement on different scales. We made an archive of the digital stories, along with the transcripts, on Stories Matter, an oral histories database that allows effective organization of data according to contents and themes. Smith College and WGBY-TV, our collaborator in the project, now aim to publicly broadcast these stories. We predict that broadcasting the stories will foster community engagement and create a sense of understanding and empathy in the community.

To analyze changes in the participant's mental health before and after the workshop, we performed statistical analysis using SPSS to determine the changes in the participants' self-determination, aptitude and confidence in computer skills, autonomy and mood. We also examined the content of the participants' stories after transcribing them to ascertain how language conveys the state of one's mental health. We used the software Linguistic Inquiry and Word Count (LIWC) to analyze the language and content of the stories. We ran analyses of individual as well as collective stories to check for themes, negative and positive emotion words, frequency of pronoun usage etc. Completion of the TOLD project will allow us to understand more clearly the relationship between words and mental health, and how oral storytelling projects can contribute to a community. (Supported by the Frances Baker Holmes Fund)

Advisor: Philip Peake

References:

- ¹Ramirez-Esparza, N., & Pennebaker, J.W. (2006). Do good stories produce good health? Exploring words language and culture. *Narrative Inquiry*. 16(1), 211-219.

Pragmatics in Children with High Functioning Autism Spectrum Disorders

Jacqueline Baron

As a continuation of the work done regarding language pragmatics in children with Autism Spectrum Disorders (ASD), particularly that currently being conducted by Peter de Villiers, we examined videos of young children with high functioning ASD for elements of their social use of language, particularly regarding contingency, or relevance of speech to the conversation, with the goal of one day creating a pragmatics assessment for children with ASD. We transcribed videos of children between the ages of 3;11 and 7;11 who have been diagnosed with an ASD but demonstrate no significant language delay interacting one-on-one with a parent in a room with toys and other materials. Several of these children were filmed again a year later, and we began transcribing those videos as well. At the time, or times, when they were filmed, the children were tested on oral language expression, language comprehension, verbal IQ, and nonverbal IQ.

Though we are still in the process of transcribing the videos, once that is complete we will analyze the transcripts of these interactions on several dimensions. First, we will code each transcript using the Index of Productive Syntax, or IPSyn. The IPSyn looks at the frequency with which 56 different linguistic forms of varying complexity are used in a given speech sample. It looks at four categories of forms: nouns, verbs, questions and negations, and sentence structure. Additionally, we will be examining the children's contingency in their conversational speech—that is, whether or not things the child says directly relates to what was said immediately before—using the coding scheme developed by Tager-Flusberg and Anderson.¹

As we have not yet reached the point of coding or analyzing data, it is difficult to draw conclusions at this time. Through this research, however, we hope to gain a better understanding of what factors are related to conversational contingency in children with ASD. We will look at possible relationships between conversational contingency and IPSyn scores, oral language expression scores, language comprehension scores, and verbal and nonverbal IQ scores. Ultimately, these results will give us a clearer picture of the significance of conversational contingency and the deficits that lie therein for children with high-functioning autism. What we have accomplished so far has been shared with students from Wesleyan University, Wellesley College, and Barnard College at an informal developmental psychology conference at Wesleyan University. (Supported by the Frances Baker Holmes Fund)

Advisor: Peter de Villiers

References:

- ¹Tager-Flusberg, H. & Anderson, M. 1991. The development of contingent discourse ability in autistic children. *Journal of Child Psychology and Psychiatry*, 32: 1123-34.

A Longitudinal Study of Personality and Life Outcomes

Shiqian Mao

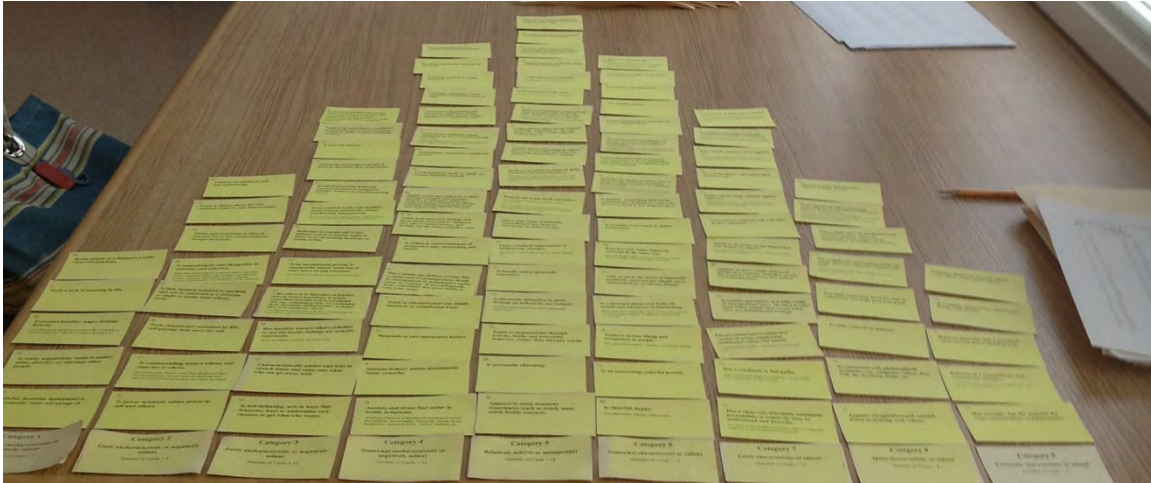

How do people's life experiences influence their personality and life outcomes? In my research, we use the California Adult Q-Set (CAQ) developed by Jack Block (1961/2008) to quantify 20-30 page interview materials collected from 26-year-old subjects. Our ultimate goal is to use age 26 CAQ data to predict age 31 life outcomes.

The CAQ procedure was developed by Jack Block (2008) at UC Berkeley to quantify different raters' perceptions of a single case by providing raters with a common "personality vocabulary" to use. The CAQ summarizes data on personality functioning and development with terms like: "Has high aspiration level for self", "Able to see to the heart of important problems", "Expresses hostility directly", and "Tends to be rebellious and non-conforming". With Professor Peterson and my lab partners, I Q-Sorted age 26 interview data from people who are part of a longitudinal study. We discussed interviews with Professor Peterson to keep us on the right track regarding our perceptions of individual subjects. Professor Peterson has been collaborating with a colleague at Wilfred Laurier University—Professor Michael Pratt—who originally collected the data from subjects at ages 18, 23, 26, and 31. Each interview contained 20-30 pages of transcribed materials concerning a subject's relationships, religious background, life regrets and high points, career goals, and future expectations.

Each subject is Q-Sorted by at least two people trained in the use of the CAQ. More than one rater is required for each subject in order to compute interrater reliabilities. A high correlation ($r > .50$, which translates to a Cronbach's Alpha above .70) between two raters is most desirable. By the end of the summer all 104 subjects were Q-Sorted by at least one rater. Sixty-eight subjects have complete and reliable Q-Sort data from multiple raters. The remaining 36 subjects either need a second or third rater. (At this point three of these 36 will need to be dropped from the sample due to low CAQ reliability aggregated across five different raters.) We will be using the completed CAQ data for further analysis. We expect to find key CAQ characteristics highly correlated with individual life outcomes at age 31. (Supported by the Frances Baker Holmes Fund)

Advisor: Bill Peterson

References:

Block, J. (1961/2008). *The Q-Sort method in character appraisal*. Washington, DC: American Psychological Association.

The Use of Small Clauses in Young Children: An Eyetracker Study

Katherine Margulis



Image: a scene from the eyetracker screen in our experiment

This summer, we decided to look more closely at the root of young children’s language and grammar by studying small clauses. Small clauses are the first complex clauses—clauses with more than one verb—that young children use. They are distinct in that the second verb is not tensed. These can be seen, for example, in the sentences “Let me go” or “I make him eat.” Later sentences, however, use infinitival clauses where the second verb needs to have a tense. This can be seen in “I want him to eat.” It is the first verb that dictates whether or not the second will have a tense marker.

Shortly after children begin to use small clauses, they develop an understanding of tense. There is a theory that all new verbs that a child learns after they learn the concept of tense will take infinitival clauses, but all verbs learned before a child understands tense take a small clause.

We decided to test this using the eyetracker, a piece of equipment which follows the subject’s eyegaze, so that we can record where they are looking. Over the summer we began testing two-year-olds to see if they have learned tense already, whether this impacts their use of small clauses following new verbs.

A child is shown six sets of videos, each with two boys and two girls. They hear a sentence pair with each set, for example, “The boys meep the girls to catch the ball” or “the boys meep the girls catch the ball.” They would then see a set of videos with boys helping girls catch a ball in one, and boys doing a random action while girls catch balls on their own in another. We would expect that, if a child already has a concept of tense, they would look at the boys helping the girls catch the ball when they hear “The boys meep the girls to catch the ball” because this is a novel verb, and we predict that children who have tense will assume that sentences beginning with new verbs require that the second verb be tensed. We would expect that if these children heard “The boys meep the girls catch the ball” they would look at the boys doing a novel action while the girls catch a ball, because they no longer assume that new verbs are used in small clauses, so they see this sentence as a conjunction.

I presented this research at an informal conference at Wesleyan University this summer, and will continue to work on it in the 2012-13 school year. We hope to test about 50 subjects to get a good idea of how and when small clauses are used in early language. (Supported by the Frances Baker Holmes Fund)

Advisor: Jill deVilliers

“White” or “European American”: Priming In-group Prototypic Features versus Mere Self-categorization and Intergroup Differentiation

Mia Copeland-Brock

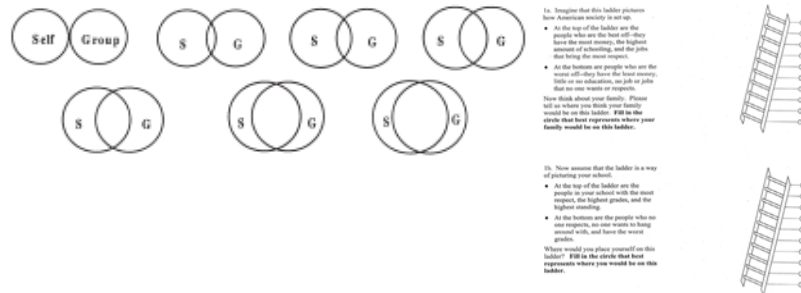

My SURF project consisted of designing and implementing the features of an experiment which will be run in the upcoming fall. In previous research, scholars have sought to obtain a greater understanding of “White” identity and how it may influence viewpoints and behaviors toward minority groups in the United States. In their work on the effects of calling attention to features of white participants’ “White” identity, Morrison and Chung (2011) found that when subjects were primed with “White” they exhibited greater prejudice and less support for multiculturalism than other White subjects who were not primed. They interpreted this difference to indicate that prototypic features of the “White” category include prejudice toward out-groups.

I believe that this observed effect can be explained more simply by other processes. Morrison and Chung (2011) primed their subjects by using a common U.S. census item which invited participants to indicate their race or ethnicity by choosing one of six racial categories. They created a control condition by moving the census item to the end of the survey. By design, this unconventional priming technique induces self-categorization and intergroup differentiation processes which lead individuals to display greater in-group favoritism and more out-group antipathy, regardless of the category that is chosen.

I will replicate and extend this previous work by introducing several additional conditions which draw White subject’s attention to the fact that they belong to the White or European American category. There are three additional conditions used in this study. Like Morrison and Chung (2011), in one condition the “White” category in the Census item will be substituted with “European American”. In a separate condition, White participants will select “European-American” and be required to specify their country of ancestry. We include an open ended condition in which participants will indicate their racial category without viewing other racial categories. It is important to note that this condition strips away the intergroup differentiation element of the U.S. census items. We are also interested in the data of all participants, because we expect that regardless of racial category, participants will exhibit greater in-group favoritism and out-group antipathy.

Prejudice and multiculturalism will be assessed using scales on attitudes toward Whites, Blacks, and immigrants, as well as a previously validated Multiculturalism Scale. Socioeconomic status, political affiliation, immigrant generation, and level of ethnic identification will also be considered. It is expected that white subjects in the “White” condition will exhibit the most in-group favoritism and out-group antipathy, while those in the “European-American specify” condition will exhibit the least in-group favoritism and out-group antipathy. As White subjects’ attention is called to their European ethnic identities, they may view themselves as being less in the majority and thus may exhibit better attitudes toward other minority groups.

Overall, this work has the potential to act as framework for future designs. This experiment can be replicated with other social groups and may help to identify the way in which priming can be used as an effective means of manipulating intergroup interactions. (Supported by the Frances Baker Holmes Fund)

Advisor: Fletcher Blanchard

References:

Morrison, K. R., & Chung, A. H. (2011). “White” or “European American”? Self-identifying labels influence majority group members’ interethnic attitudes. *Journal of Experimental Social Psychology*, 47(1), 165-170. Elsevier B.V. doi:10.1016/j.jesp.2010.07.019.

Creating a Mandarin Language Test in Order to Diagnose Specific Language Impairment in China

Tarra Murphy

Currently in China, there is no field of speech language pathology. Speech language pathologists do many different things, and one of those things is to diagnose children with specific language impairment (SLI) so that they can receive the help they need. Working in conjunction with Dr. Liu, a Chinese speech language pathologist in Texas, and Dr. Ning, a professor from Tianjin University, Jill de Villiers has been working on creating a Mandarin language test.

Dr. Ning and his research team created a pilot test of their own and conducted research on about 700-800 Mandarin-speaking children in China. The children varied in age, ranging from three years to nine years. The children were tested on many different things, including syntax, sentence production, pronunciation, tones, etc., for a test with almost 200 items.

The data from Dr. Ning's research was sent to our lab, and the data seemed to show that the children had scored along a favorable curve. I ran several univariate analyses of variance through SPSS, looking carefully at statistical differences for the scores on each portion of the test. From this we were able to compare how the children from each age group scored, and the significant differences between the age groups which would signal growth with age. It was concluded that some of the sections of the test were far too easy, and others far too difficult. Furthermore, there was very little growth with age by subtest. I used my basic knowledge of Mandarin as well as my linguistics training to help critique the items and suggest alternatives. After the statistics were compiled and analyzed, Jill de Villiers and Dr. Liu traveled to China to present the findings to Dr. Ning and give suggestions as how to improve the children's scores.

The research on this project is ongoing, and will continue through the school year. Also, per the request of Dr. Ning, the details of this project will not be disclosed until published. Now that the flaws of the pilot test have been identified, we hope to strengthen it by removing ambiguities, lowering the possibility of chance, and searching through published linguistic studies done on Mandarin to find inspiration for improving the test. (Supported by the Frances Baker Holmes Fund)

Advisor: Jill de Villiers

Examining the Correlates of Posttraumatic Growth in Retired Police Officers

Christina Song

Posttraumatic growth (PG) refers to positive psychological changes that can occur after a traumatic event. Previous studies have shown PG in the wake of different types of traumatic events, as well as in different populations; however, there is a dearth of information on the correlates of PG in emergency responders, such as police officers (Helgeson et al., 2006; Paton, 2005). Police officers are likely to encounter many traumatic events as part of duty-related exposure, and have elevated rates of PTSD as opposed to civilian populations. With previous studies showing that PG was correlated with lower post-traumatic stress disorder symptoms (PTSS), understanding the correlates of PG in an understudied population that is routinely exposed to traumatic events, can have significant implications (Helgeson et al., 2006).

One hundred and forty-eight police officers completed questionnaires assessing personality, PTSD symptoms, work stressors, and PG. After controlling for response biases, variables that remained significant in the final model for PG were underlying personality (extraversion), coping strategies (positive reappraisal, confrontation, seeking social support), and work stressors (administrative and equipment). The overall model significantly predicted PG, $F(7, 142) = 14.37, p < .001$ and accounted for 43% of the variance in PG ($Adj R^2 = .40$). We also found that greater posttraumatic growth was associated with less severe PTSD symptoms, particularly numbing symptoms. Finally, we found that among types of posttraumatic growth, the retired officers benefited most in the areas of personal strength and appreciation for life.

We failed to find an association between trauma exposure variables and this implies that officers may show trauma benefits irrespective of the amount of exposure. PG then, is potentially possible regardless of trauma exposure. Though police officers are at high-risk for trauma exposure and PTSD, PG is an alternative post-trauma pathway where police departments can potentially play an important role. While police departments cannot eliminate duty-related trauma exposure, they can select extraverted officers, teach positive reappraisal coping, and modify organizational practices to reduce administrative stressors to promote PG. (Supported by Frances Baker Holmes Internship Fund)

Advisor: Nnamdi Pole

References:

- Helgeson, V. S., Reynolds, K. A., & Tomich, P. L. (2006). A meta-analytic review of benefit finding and growth. *Journal of Consulting and Clinical Psychology, 74*(5), 797-816.
- Paton, D. (2005). Posttraumatic growth in protective services professionals: Individual, cognitive and organizational influences. *Traumatology, 11*(4), 335-346.

Pilot Testing of a Spanish Computerized Preschool Language Assessment

Joselina Tejada



Joselina Tejada giving a presentation at the annual Cognitive Development Research Conference hosted at Wesleyan University.

In the United States, 68.4 % of English language learners are Hispanic and, for about 75% of them, Spanish is their native language. Unfortunately there isn't any technology available that can quickly and properly assess the language development of English language learners. The computerized preschool language assessment Spanish test that Professor de Villiers and her team are currently developing is the equivalent of an English test being developed for predominantly English speaking children. Professor de Villiers has worked closely with Dr. Iglesias, a specialist in the language assessment of Spanish-speaking children at Temple University to ensure that English test items can be properly translated into Spanish and that they are culture- and dialect-neutral so to allow for the testing of diverse populations.

In order to determine the language in which the test should be administered, information about language use at home with family members and peers outside of the home will be collected. Language input and output will be quantified on a five-point scale, children that speak only Spanish will receive a one, children that speak predominantly Spanish will receive a two, children that speak Spanish and English equally will receive a three, those who speak mostly English will receive a four and those who speak only English a five. Only children whose scores average below a two will be administered the Spanish version of the test. Spanish-speaking children whose average score falls between two and 3.9 will be administered both versions.

To ensure the validation of the language assessment tool we conducted a pilot test on Spanish monolingual children. The subjects were children of migrant workers from Mexico and Guatemala who come to the United States every summer and enroll in various Head Start programs in Springfield, MA. Because I am a native Spanish speaker, Professor de Villiers decided that I should be one to administer the test. Since the majority of the migrant children had never used a computer, I explained to each child how to use the computer and gave them two practice tests as a way of familiarizing them with the process.

In total 27 children between the ages of three and five were tested. The test, which is composed of a grammar and a vocabulary module, is meant to be discriminatory by age and, as predicted, the results showed that the older children outperformed the younger ones. The data from the pilot test is very promising, however there is still a lot of work that needs to be done before the test is published. Professor de Villiers and her team are hoping that this test will help monitor the progress of preschool children as well as identify Spanish speakers that are language delayed, in addition the test will help schools assess the efficacy of their curriculum. (Supported by the Frances Baker Holmes Fund)

Advisors: Peter and Jill de Villiers

Individual Feedback Sensitivity to Social Self-Conscious Emotions

Jennifer Tran

Feedback is a critical component to the process of learning. Understanding feedback leads to adaptations and regulation of individual behavior. As social beings, humans are particularly sensitive to feedback cues that occur during interactions with others and must use this information to moderate their behavior concurrently in situations. Interpersonal relationships and the ability to process and adapt to the feedback cues influence individual's mental health. For example, previous research has shown that when accepted by their peers, adolescents form better social relationships and exhibit higher self-esteem while individuals that unable to process and evaluate cues dynamically are rejected which can manifest into social avoidance, anxiety and depression.¹ Related to the processing of social feedback is the experience and expression of self-conscious emotions. Self-conscious emotions include shame, guilt, and pride. They are individual personal emotions that are evoked through self-reflection and perception of situations. These emotions provide feedback to certain personal behaviors that allow for the individual to process the appropriateness of their actions. Past studies on the emotional effects of social feedback cues have used global assessments such as questionnaires and behavioral tasks as well as spatially sensitive measures of brain function such as fMRI. However I am interested in whether the immediate emotional impact of social feedback cues can be differentiated in neural markers that are temporally sensitive such as event-related potentials (ERPs).

To do this we designed and programmed a version of the flanker paradigm. The flanker paradigm requires participants to look at a central item in a row of stimuli while ignoring the other flanking stimuli. After each set of stimuli the participant is presented with a feedback screen showing how well they performed compared to their peers. This peer comparison feedback was presented as a single line divided into three colors (red, yellow, and green) with an arrow pointing to the participant's performance. There were three general forms of feedback: "worse than"(red), "equal to"(yellow), and "better than"(green) their peers. The "worse than" feedback attempts to illicit minor feelings of shame, while the "better than" feedback was used to evoke minor feelings of pride. Within these three types of feedback, there are two different degrees of variation. For example, in the "worse than" feedback there are two possible arrow locations where one represents doing a lot worse than average and the other representing only doing a little worse than average. We have piloted this paradigm to begin to examine the patterns of neural markers associated with the self-conscious emotions (pride and shame). These patterns show that there is a slight difference in the two degrees of negative feedback. There is a difference in what can be seen as a possible P2 or P3 which is not quite so clear due to the lack of participants (see Graph 1). The positivity component (P2/P3) is related to stimuli salience and the premature results show a possible difference between attentions towards the two different variations of feedback screens. With additional participants we will be able to confirm the specific ERP components associated with processing the emotional feedback. (Supported by the Frances Baker Holmes Fund)

Advisors: Beth Powell and Jennifer Martin McDermott (University of Massachusetts, Amherst)

References:

¹Rubin, K.H., Bukowski, W.M., Parker, J.G., (2006). Peer interactions, relationships, and groups. *Handbook of Child Psychology* 3(6), 571-645.

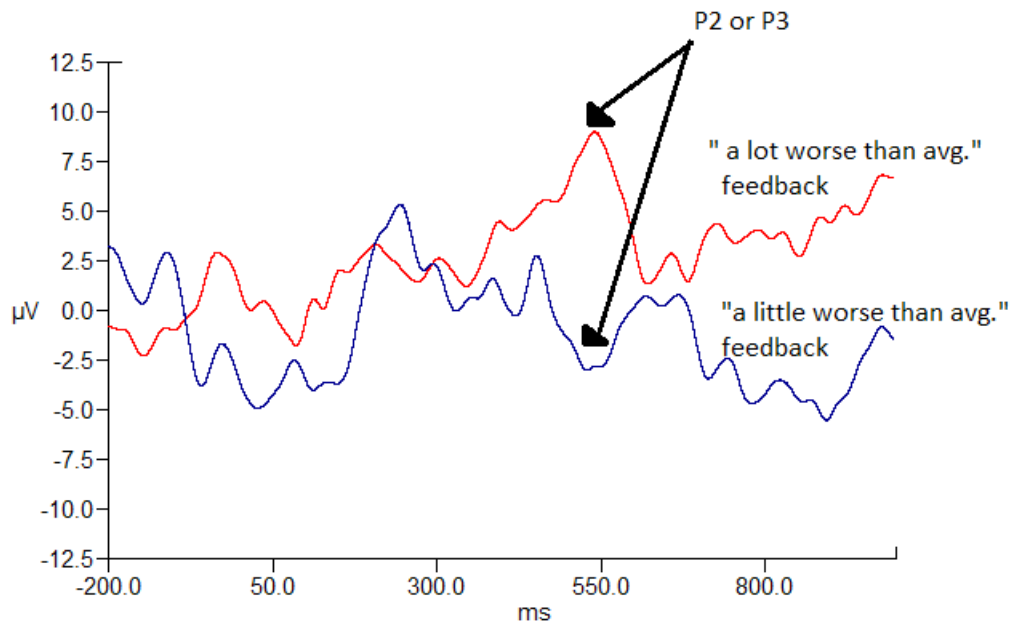

This graph shows a possible significant difference in a P2 or P3 peak between the two different degrees of negative “worse than” feedback on the CZ channel

A Longitudinal Study of Personality and Life Outcomes

Xiaoye Xu

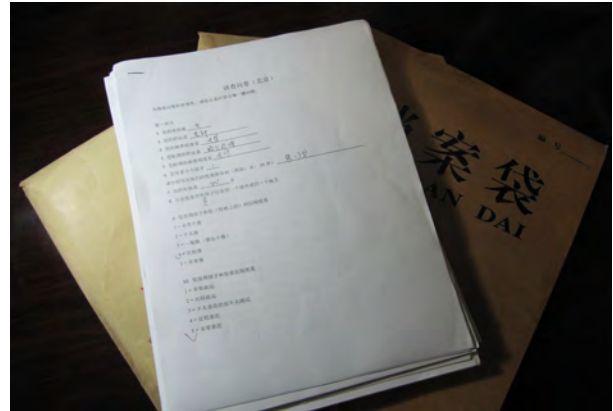

How can we understand personality comprehensively and predict people's future decisions? In my research on personality and life outcomes, I worked with Professor Peterson to Q-Sort age 26 interview data from people who are part of a longitudinal study. Professor Peterson has been collaborating with a colleague at Wilfred Laurier University, Professor Michael Pratt, who originally collected the data from subjects at ages 18, 23, 26, and 31. The Q-Sort is a measurement technique used by psychologists to quantify data on personality functioning and development. Our ultimate goal is to use age 26 Q-Sort data to predict age 31 life outcomes. I quantified 80 interviews with the Q-Sort. Each interview contained 20-30 pages of transcribed information about a subject's work life, relationships, goals, regrets, and religious upbringing.

For our study we used the California Adult Q-Sort developed by Jack Block (1961/2008) at UC Berkeley to standardize different raters' perceptions of the same individual by providing raters with a common descriptive language to use. Examples of CAQ items include: "Is uncomfortable with uncertainty and complexity", "Keeps people at a distance", "Has warmth", and "Is productive". Over the summer I Q-sorted the interviews with Professor Peterson and other lab members. Multiple raters for each interview are necessary to establish levels of interrater reliability. At the beginning of the summer we established reliability by reading the same interview, conducting our Q-Sorts independently, and then discussing each case extensively. Our discussions broadened my horizons about how people live life, and enlightened me in ways that I hope will lead me to be more open and creative.

At the end of this summer's research, our lab had finished Q-sorting all 104 subjects at least once. We have reliable CAQ data for 68 subjects (65% of the sample). The remaining 36 subjects still need a third or fourth rater for reliability purposes. During the coming academic year we will complete the remaining Q-Sorts, enter the composite data into SPSS, and generate reliability, descriptive, and inferential statistics. Regarding the inferential statistics, we will examine how personality as assessed by the CAQ at age 26 predicts levels of generativity (i.e., desire to invest in society and care for others) and authoritarianism (i.e., cognitive rigidity and aggressiveness) at age 31.

Through the SURF I was given the opportunity to practice basic principles of personality and developmental research that I learned about in my Research Methods class. In addition, as an international student from China, reading records of interviews from North American citizens provided me with a useful resource to understand western culture, which is important to my future goals to compare Asian and western cultures. For example, from the interviews, I found out a lot about North American parenting practices and I could not help but compare this to Chinese parenting. I am developing plans now to write an honors thesis with Professor Peterson about Chinese parenting practices and will collect a pilot study in my junior year. (Supported by the Frances Baker Holmes Fund)

Advisor: Bill Peterson

References:

Block, J. (1961/2008). *The Q-Sort Method in Character Appraisal*. Washington, DC: American Psychological Association.

