

Mg_3O_3

Periclase

MgO



Periclase



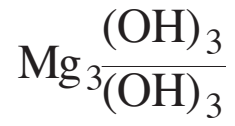

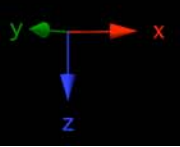
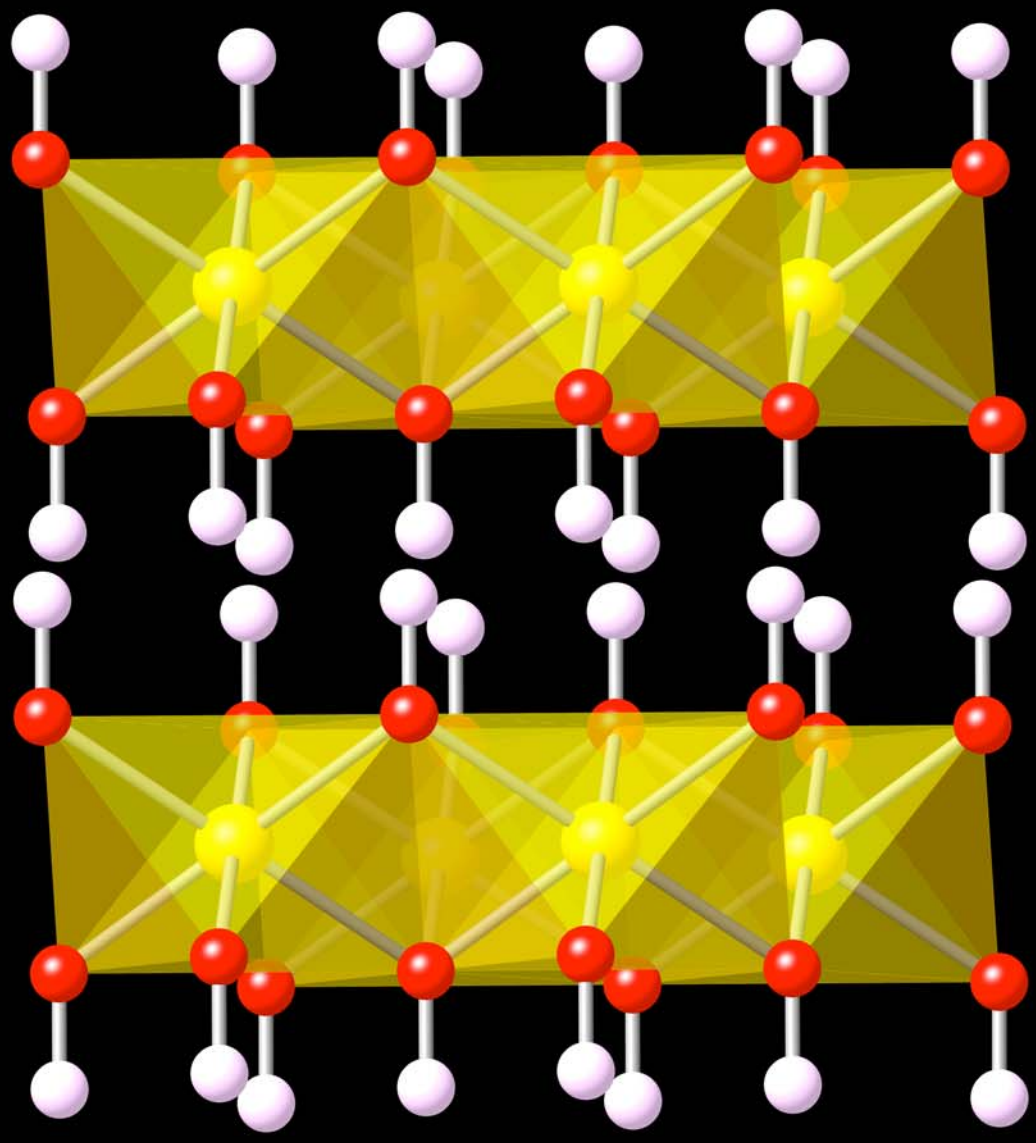

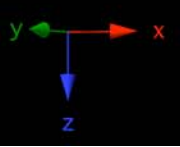
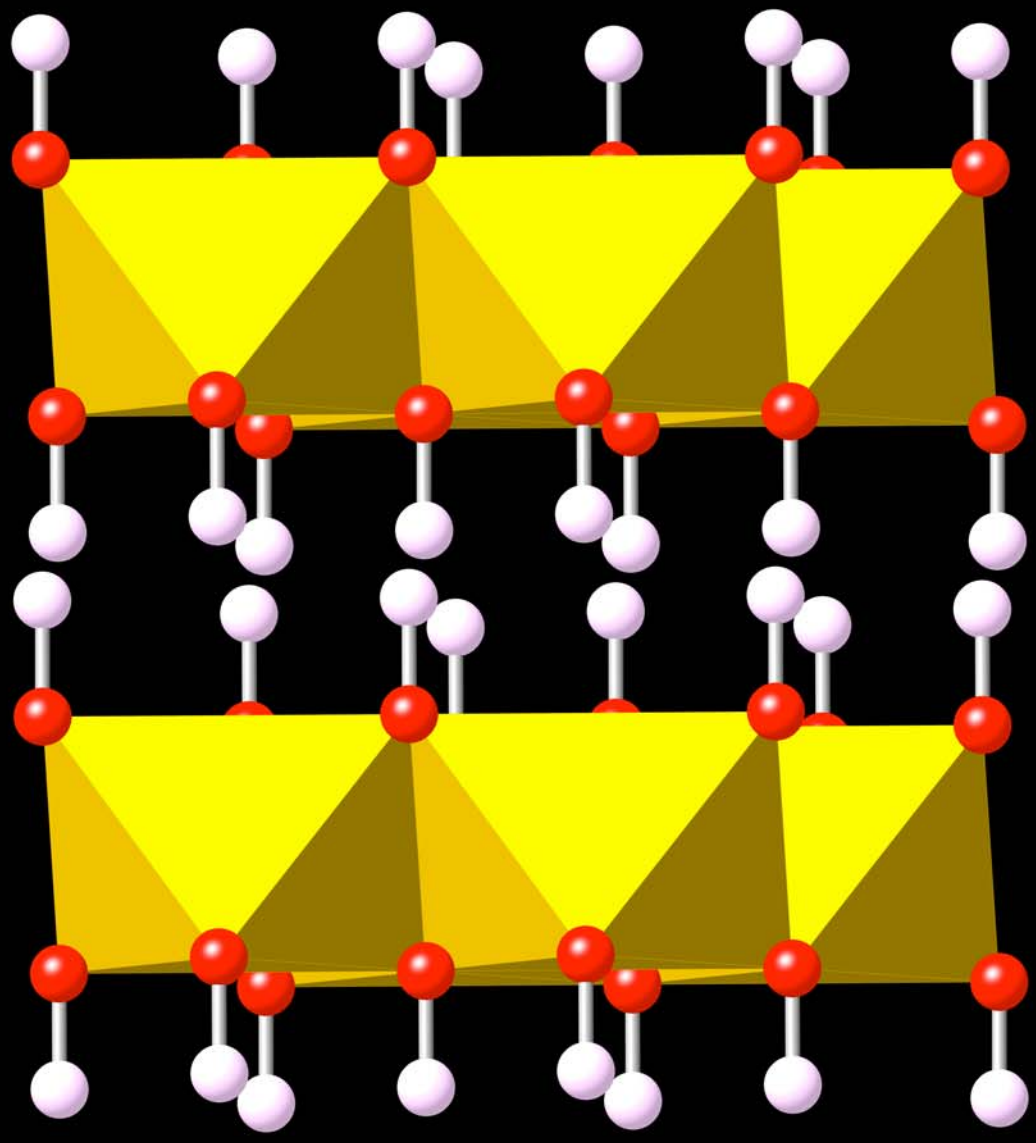

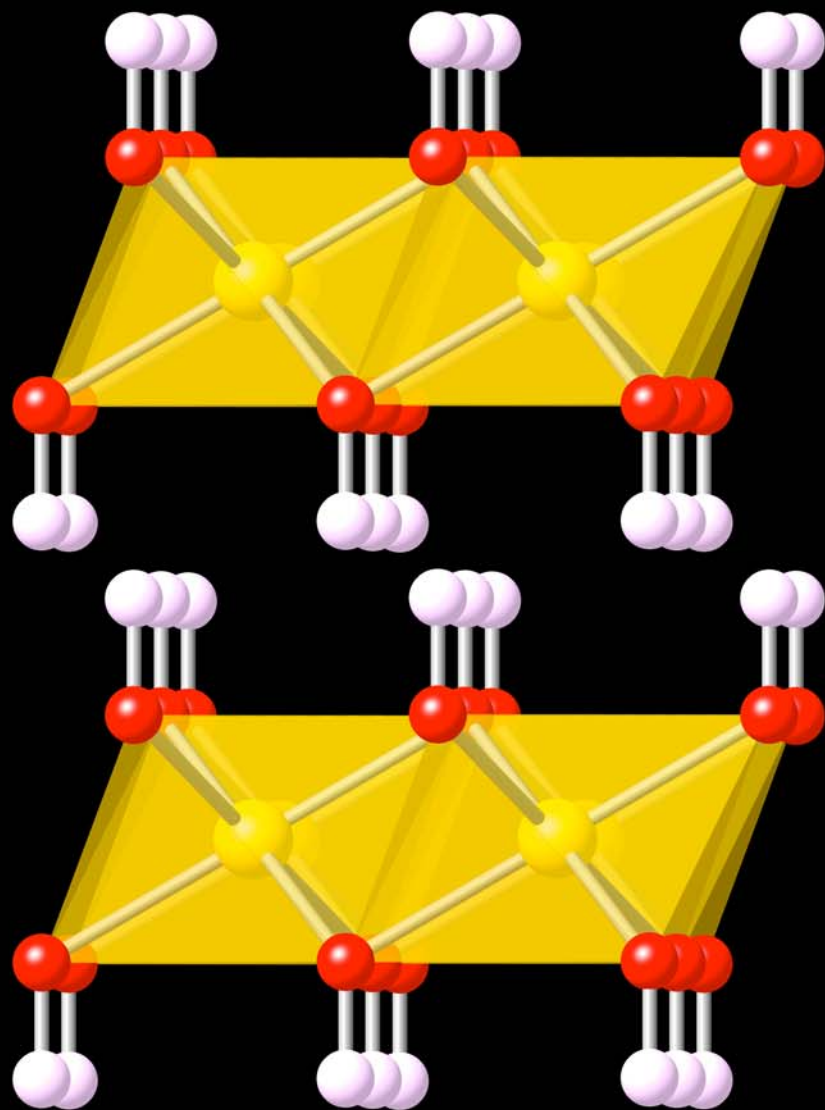

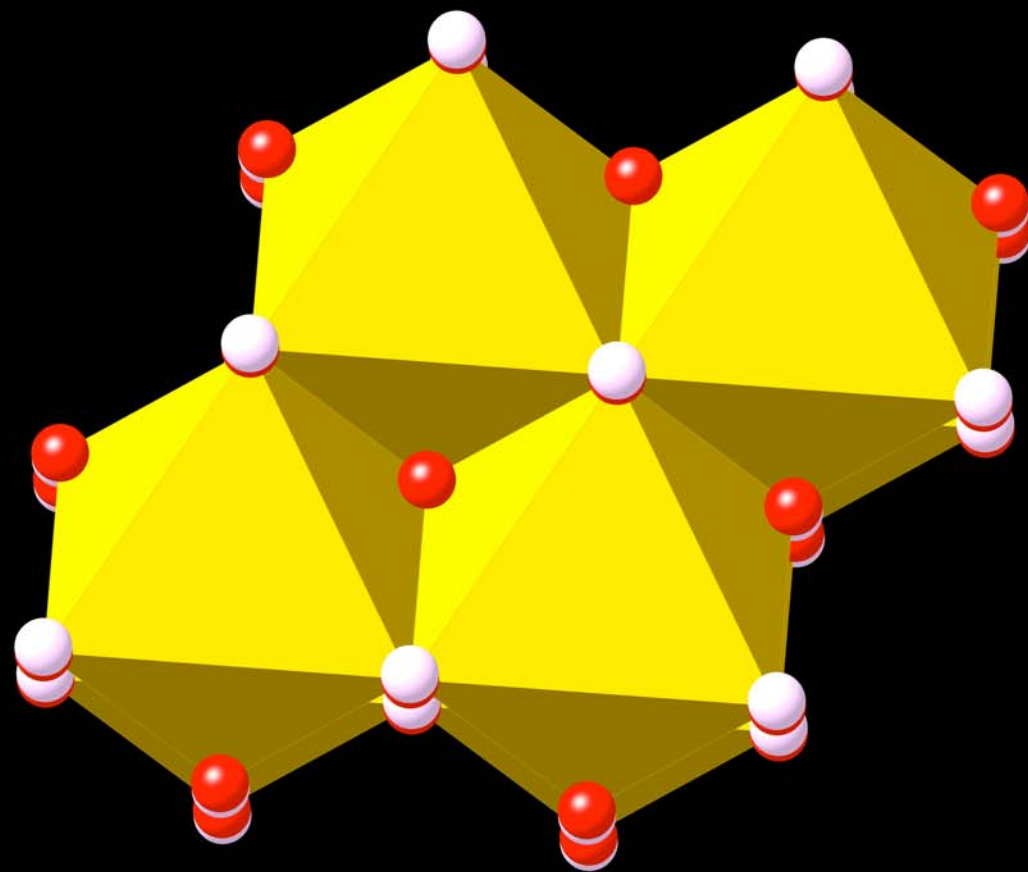

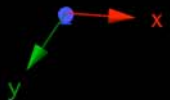
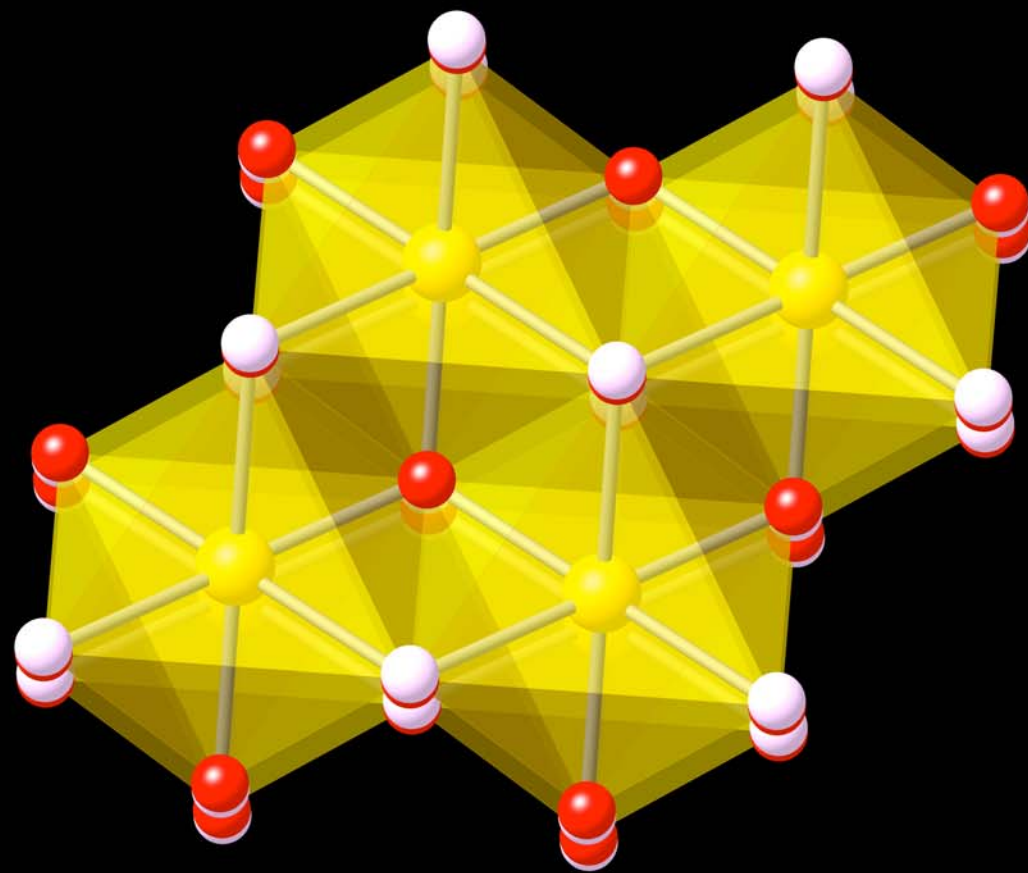



Periclase



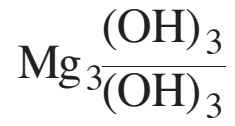

Brucite



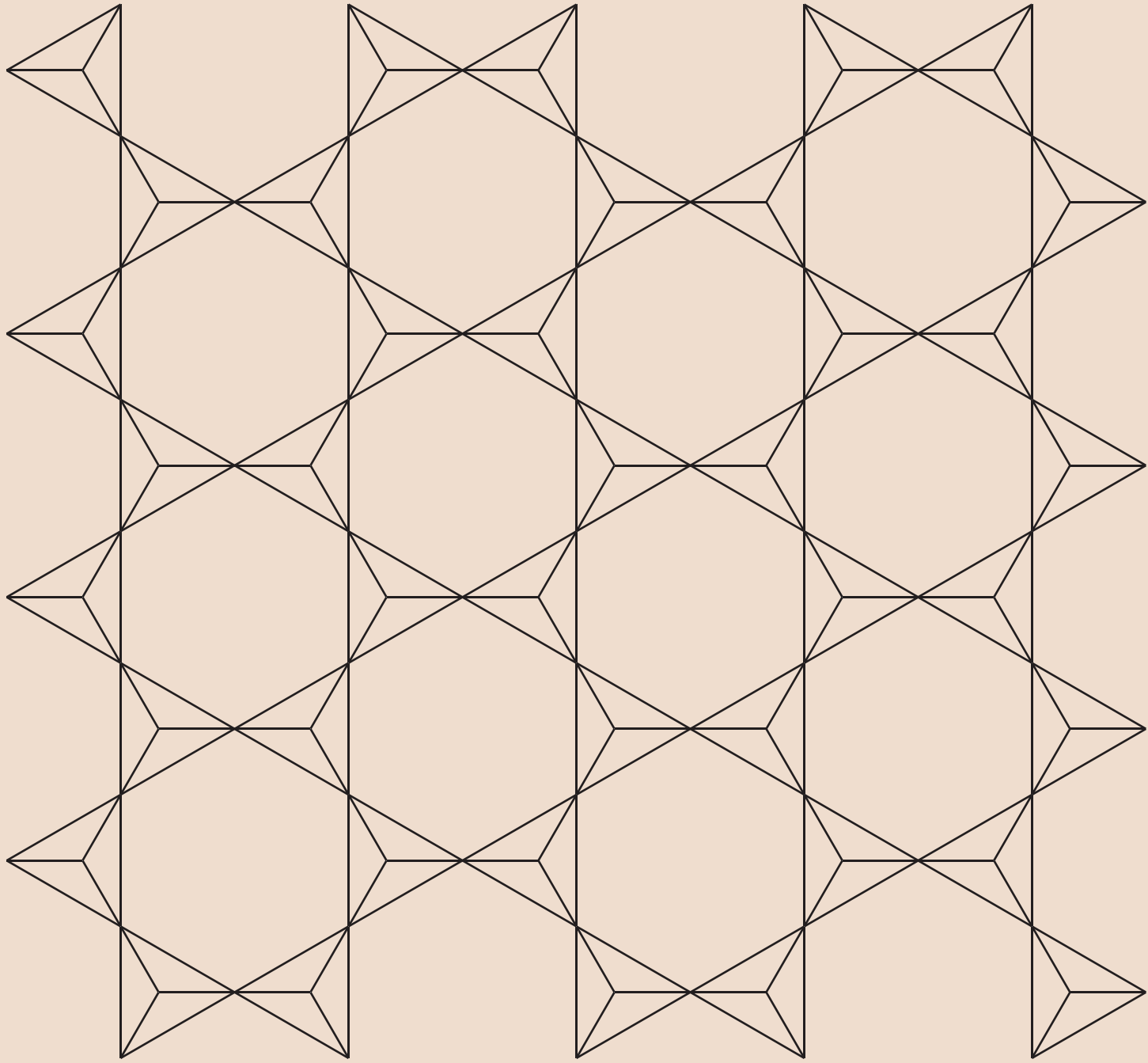

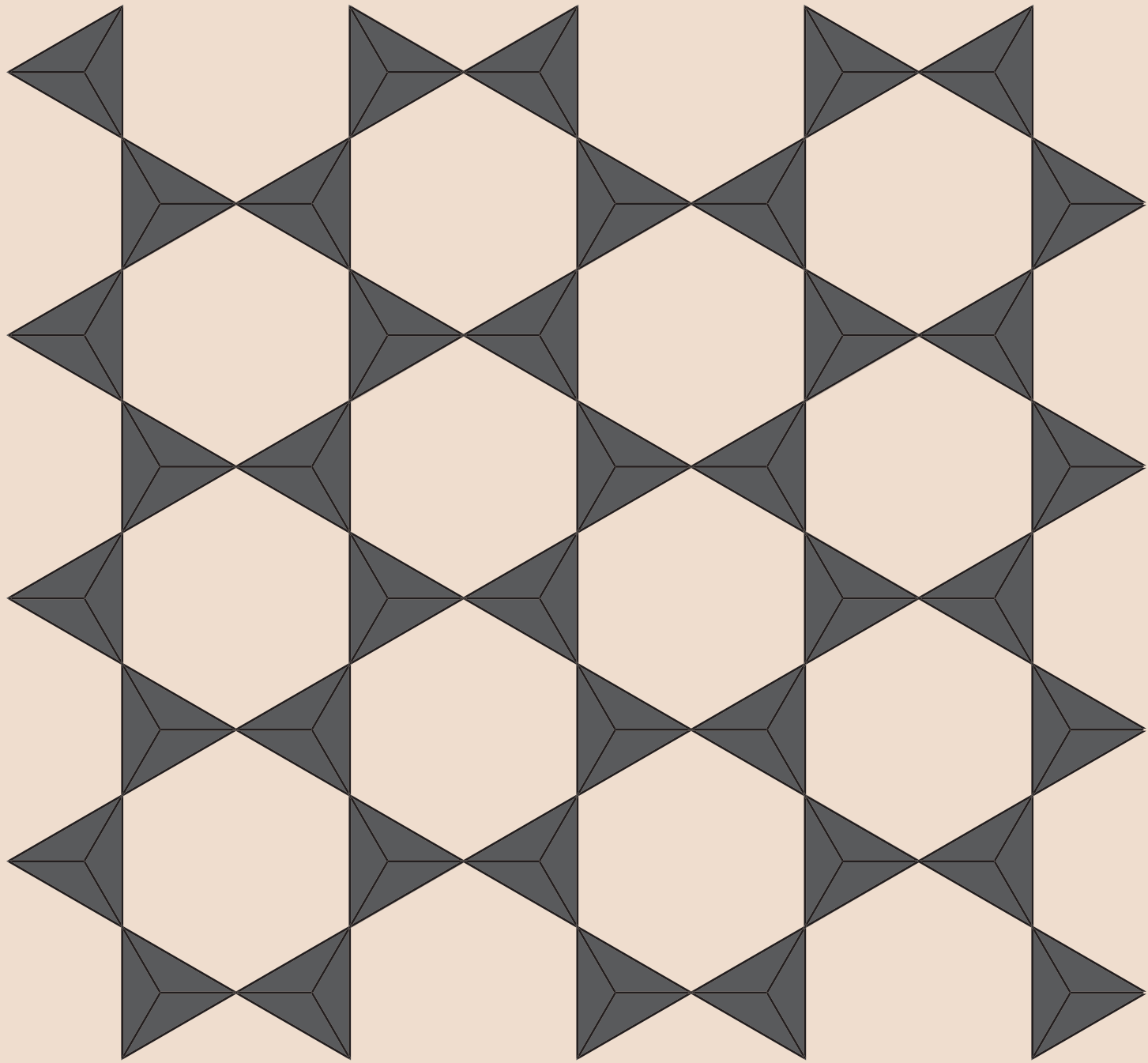

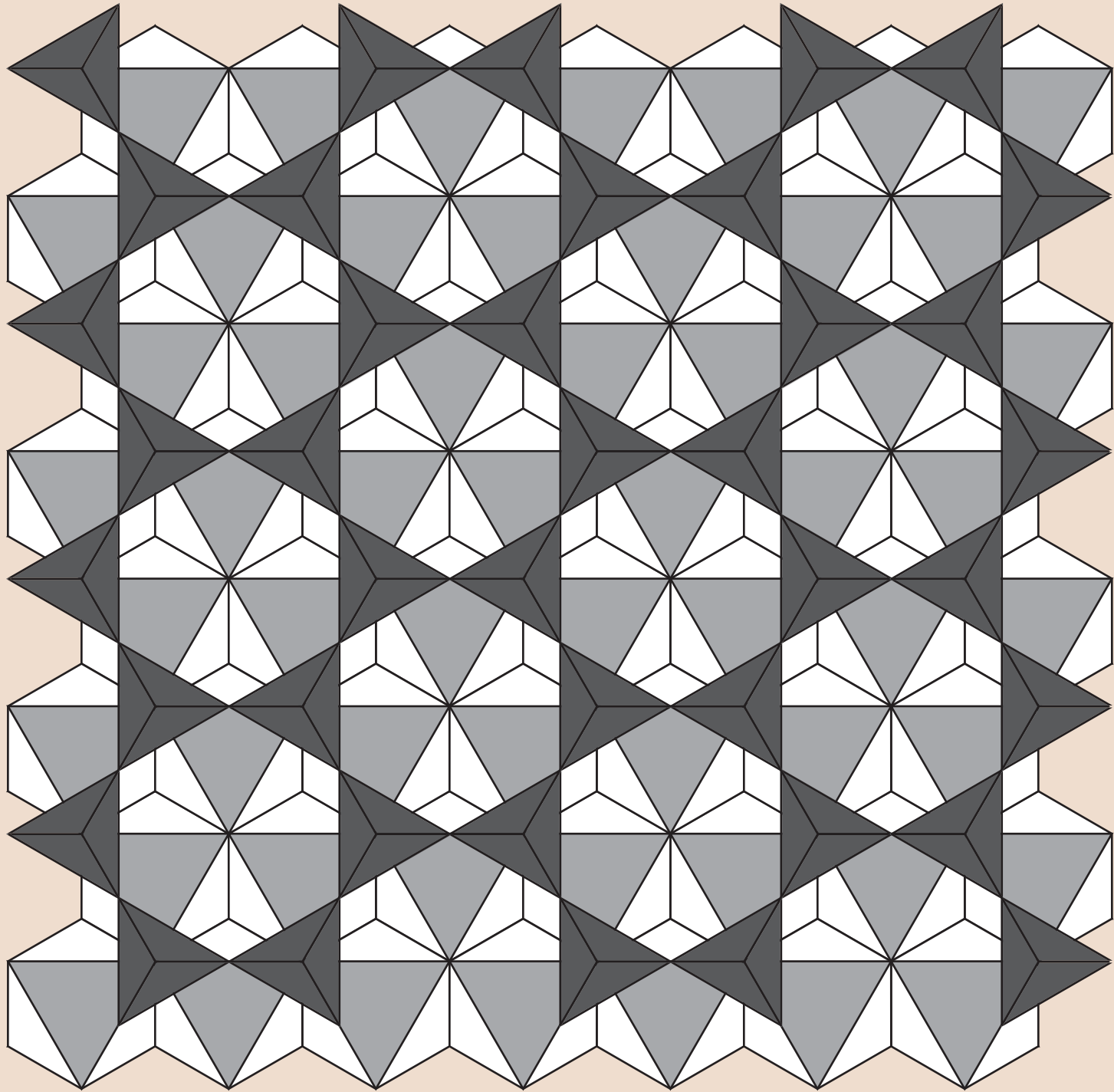

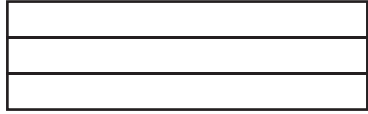

Periclase

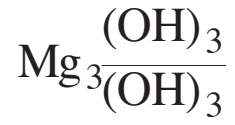
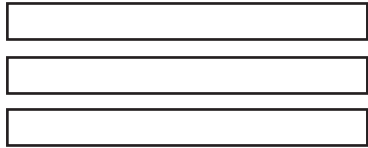

Brucite

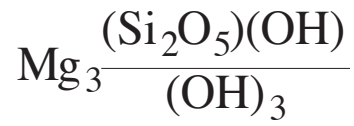
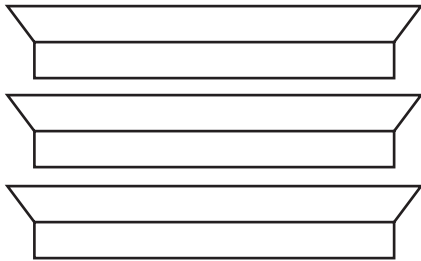



Periclase

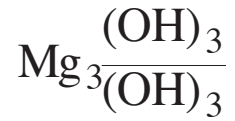
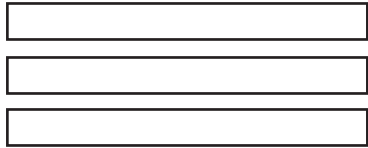

Brucite

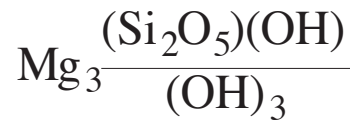
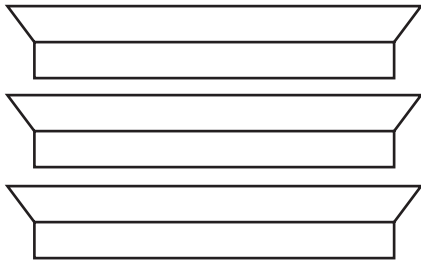

Antigorite
Lizardite
(Serpentine)

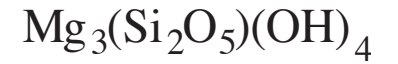

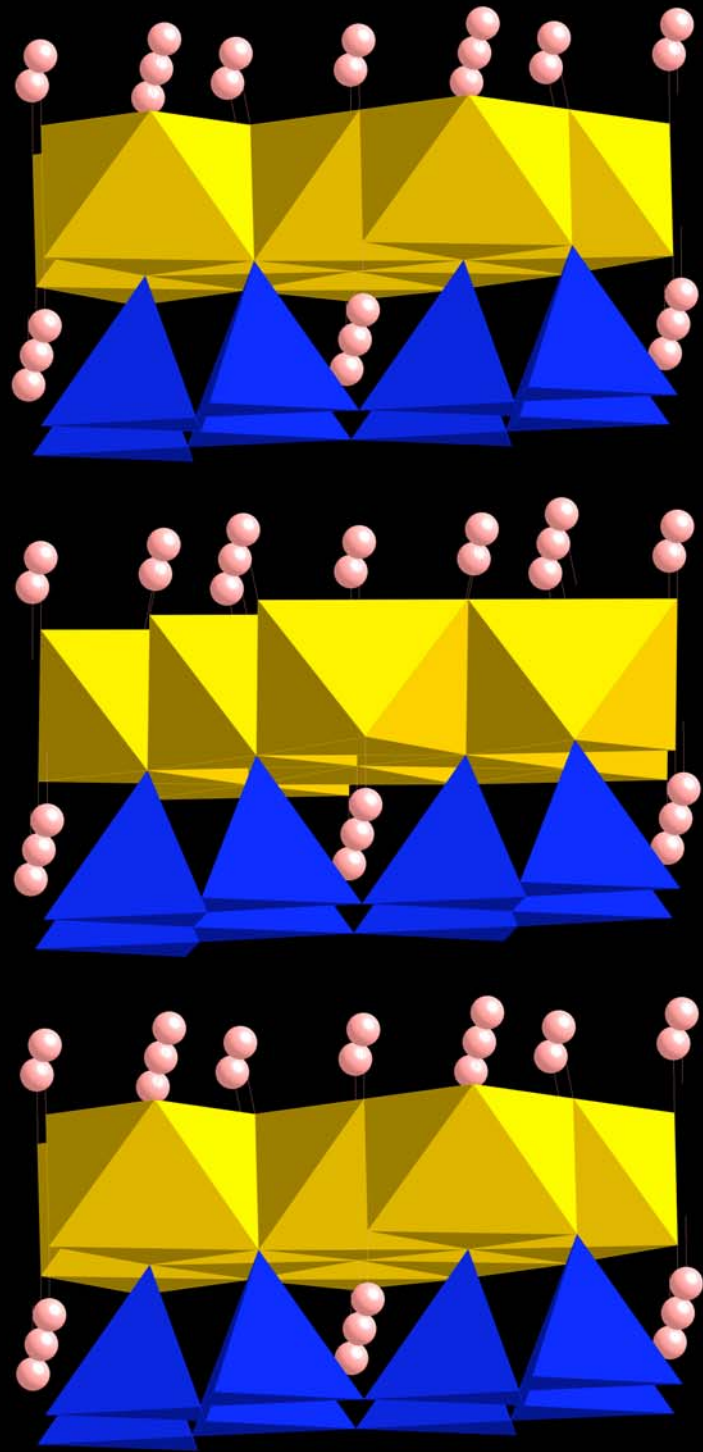

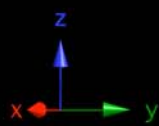
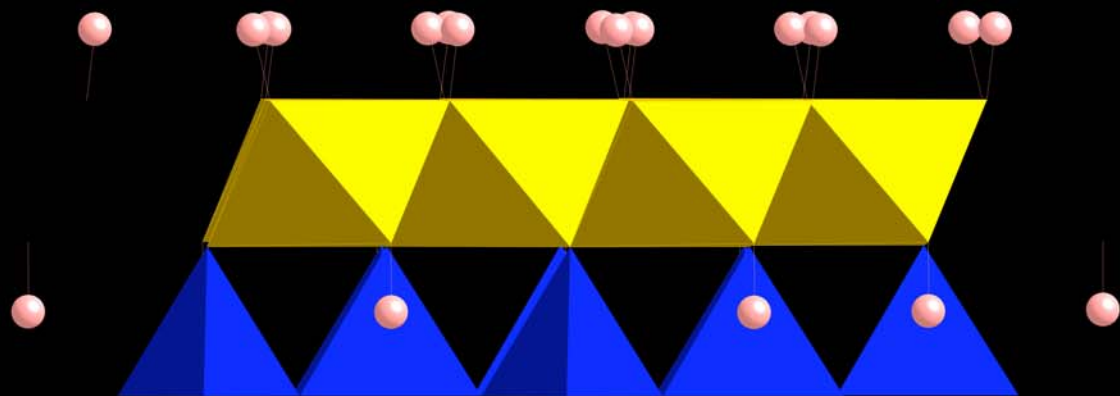
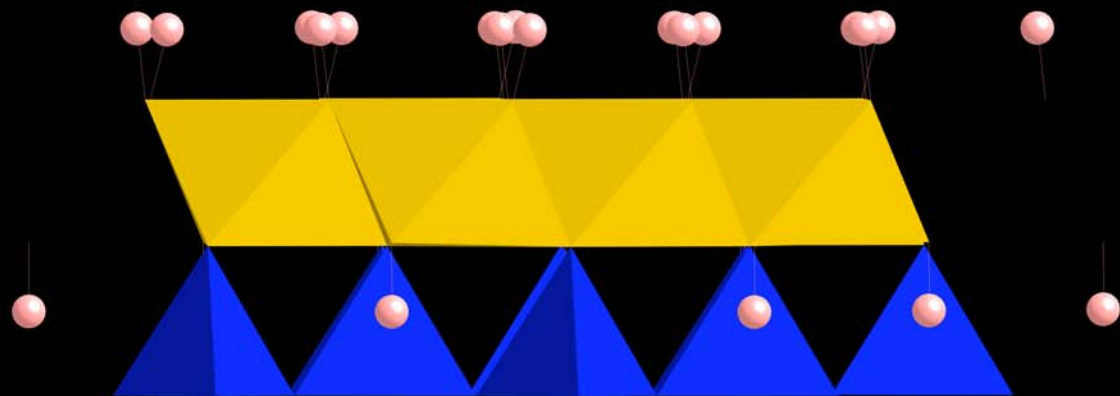
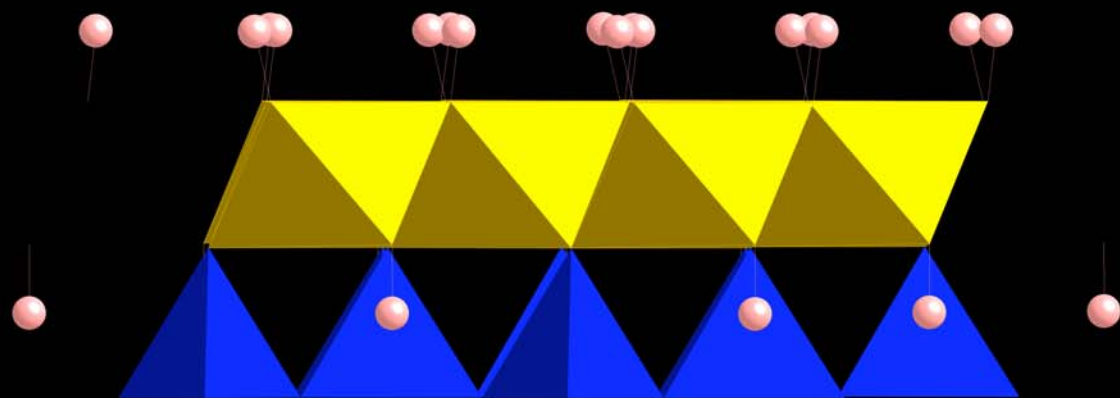

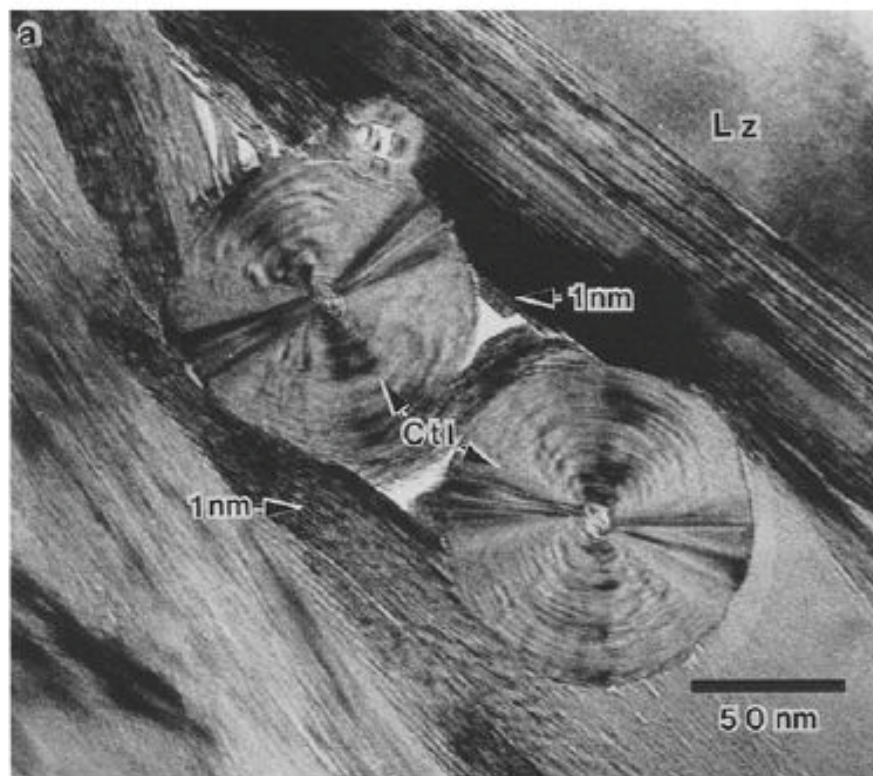

Fig. 3a, b. TEM micrographs (a and b) of disrupted regions containing chrysotile fibers (*Ctl*) as well as lizardite (*Lz*), phlogopite (*Phl*), and 1.0-nm material. The disrupted region (b) also contains curved serpentine (*C*) associated with fragments of lizardite

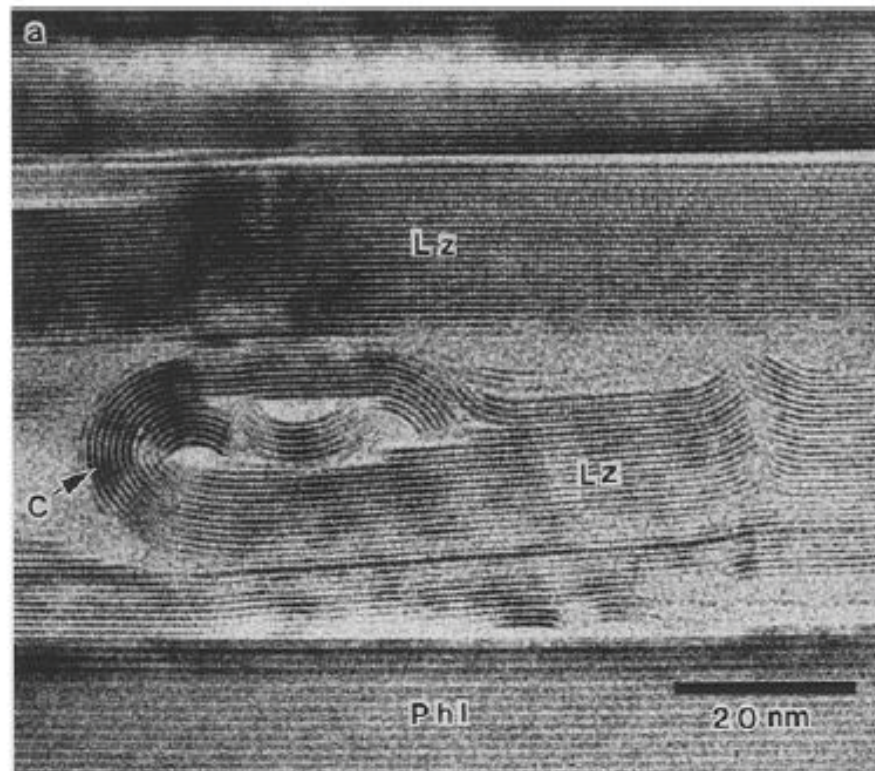
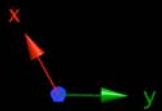
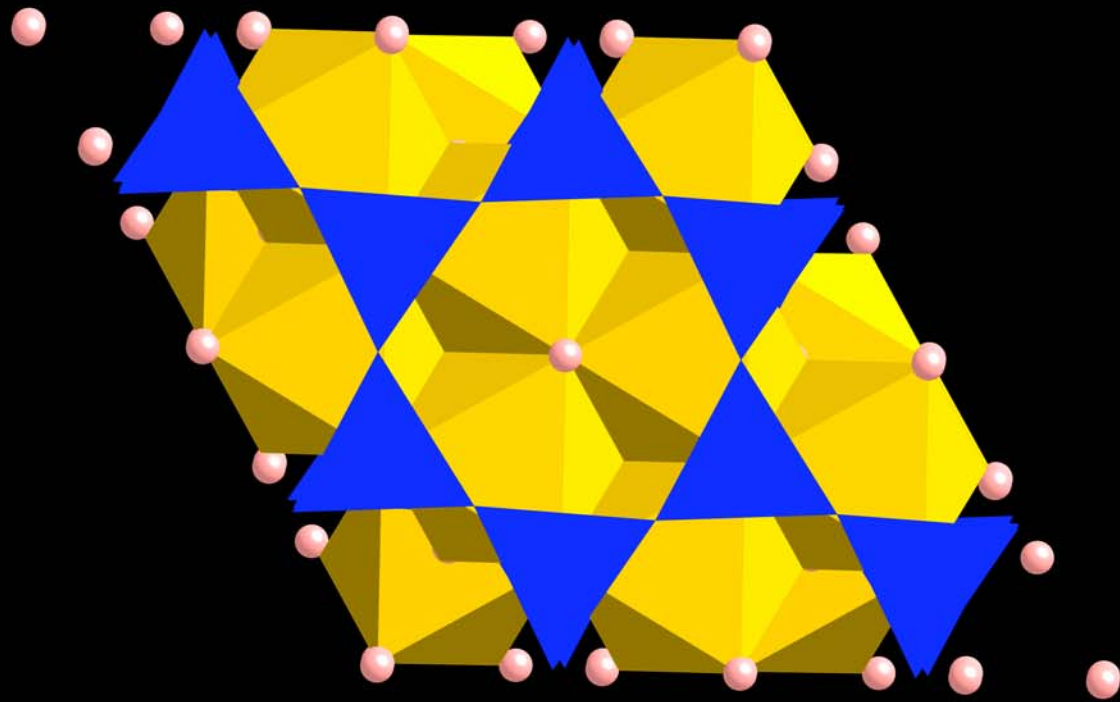

Fig. 4a, b. TEM micrographs of deformed lamellar material with curled serpentine (*C*) intergrown with lizardite (*Lz*). Curled serpentine occurs (a) along a narrow cleavage fracture and (b) in a void next to kinked and bent lamellae

Serpentinization of phlogopite phenocrysts from a micaceous kimberlite

Thomas G. Sharp¹, Max T. Otten², and Peter R. Buseck³

Contrib. Mineral Petrol (1990) 104: 530-539



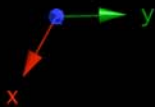
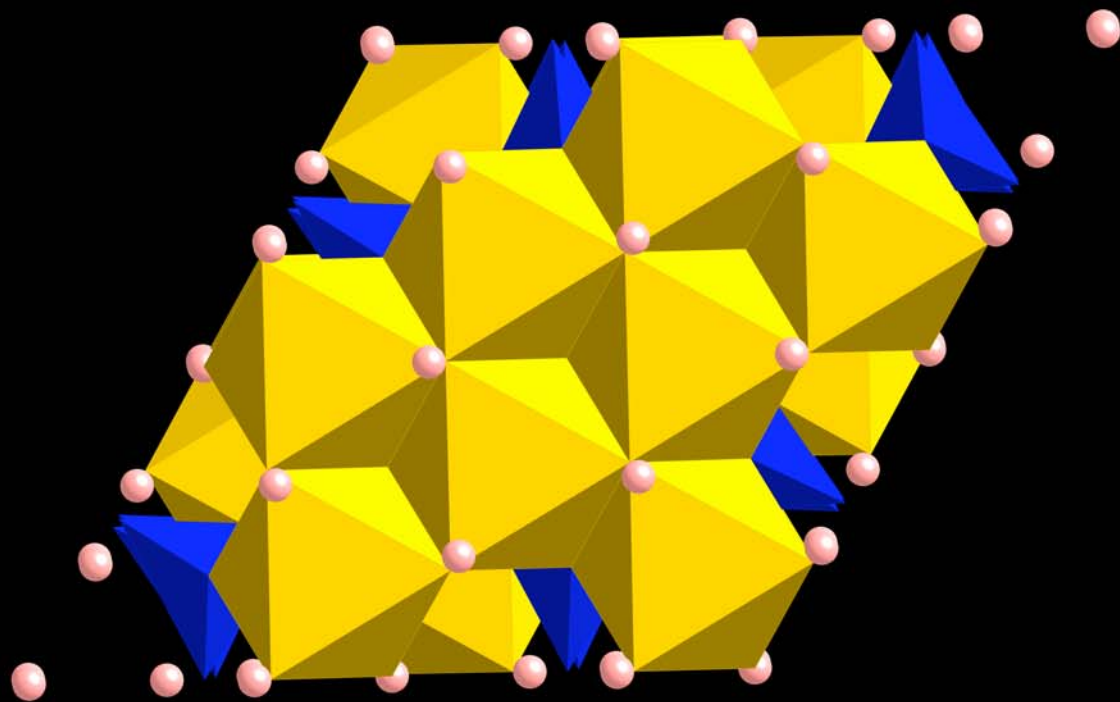

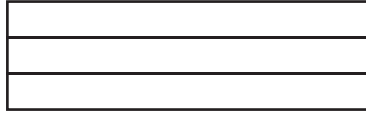

Periclase

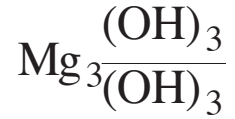
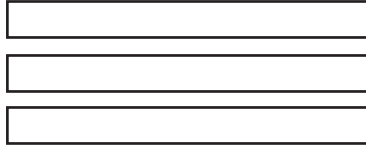

Brucite

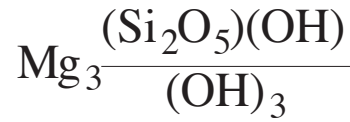
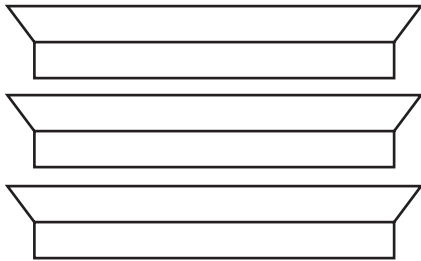

Antigorite
Lizardite
(Serpentine)

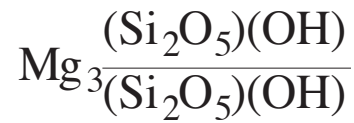
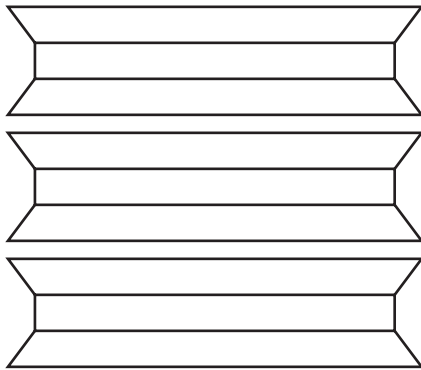
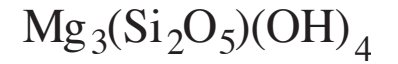

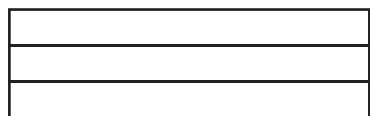

Periclase

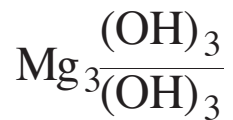
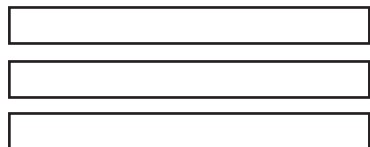

Brucite

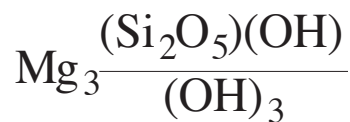
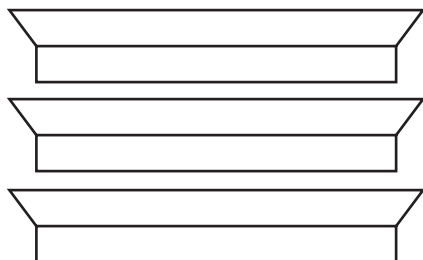

Antigorite
Lizardite
(Serpentine)

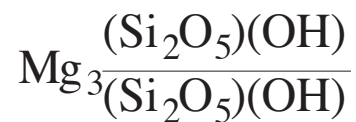
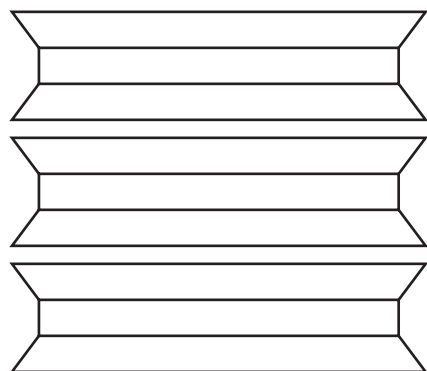
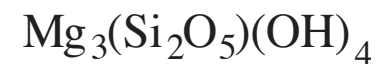

Talc



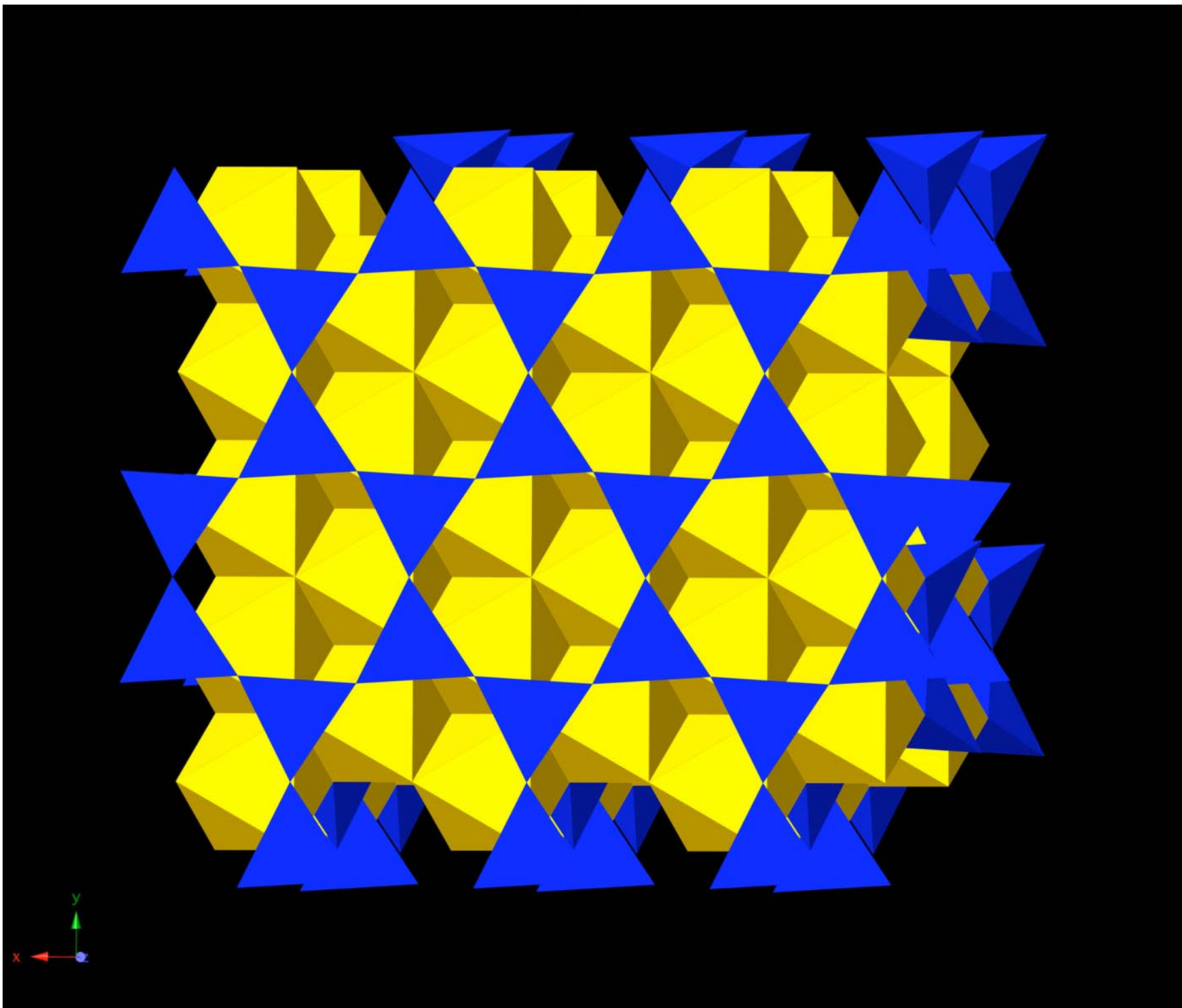

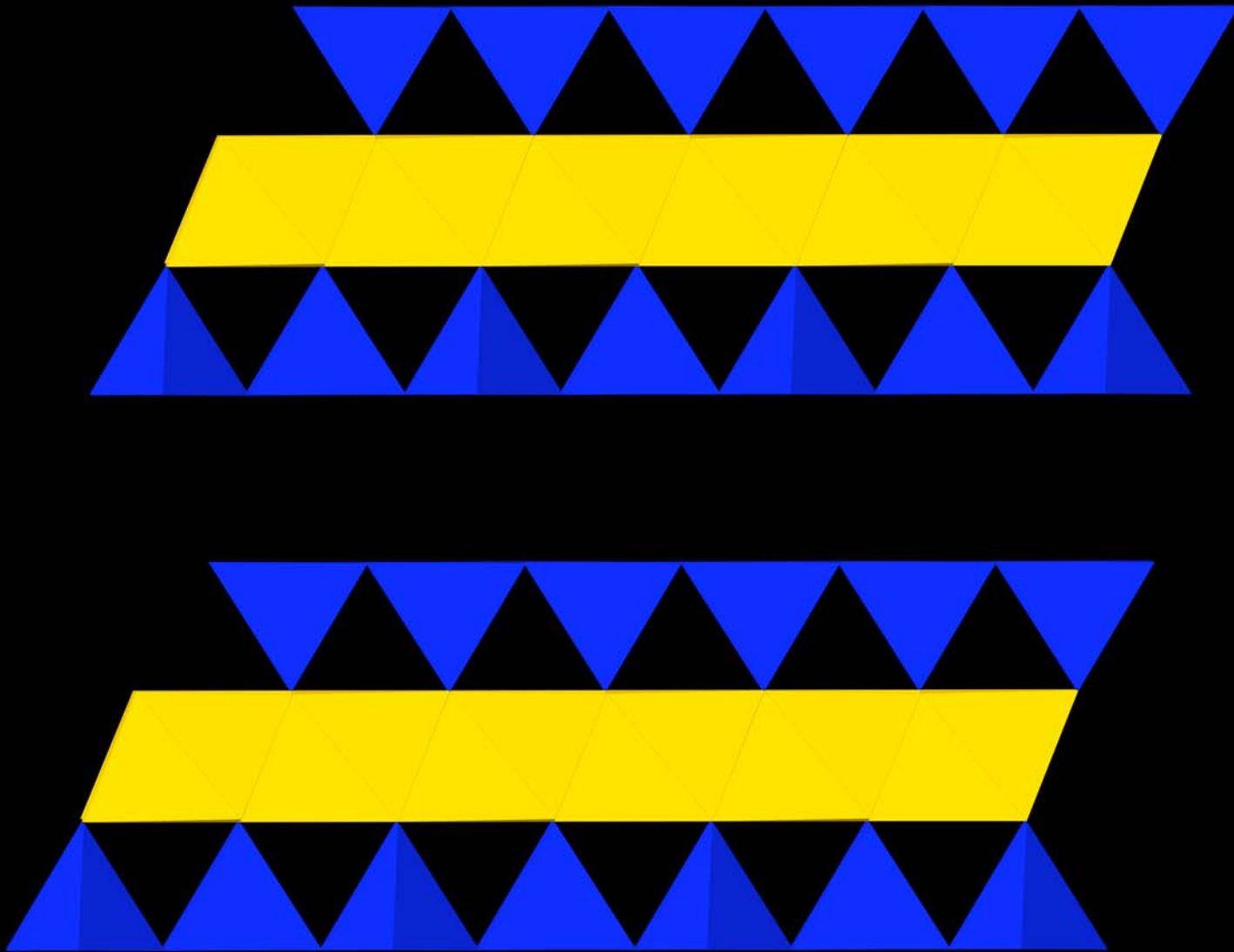

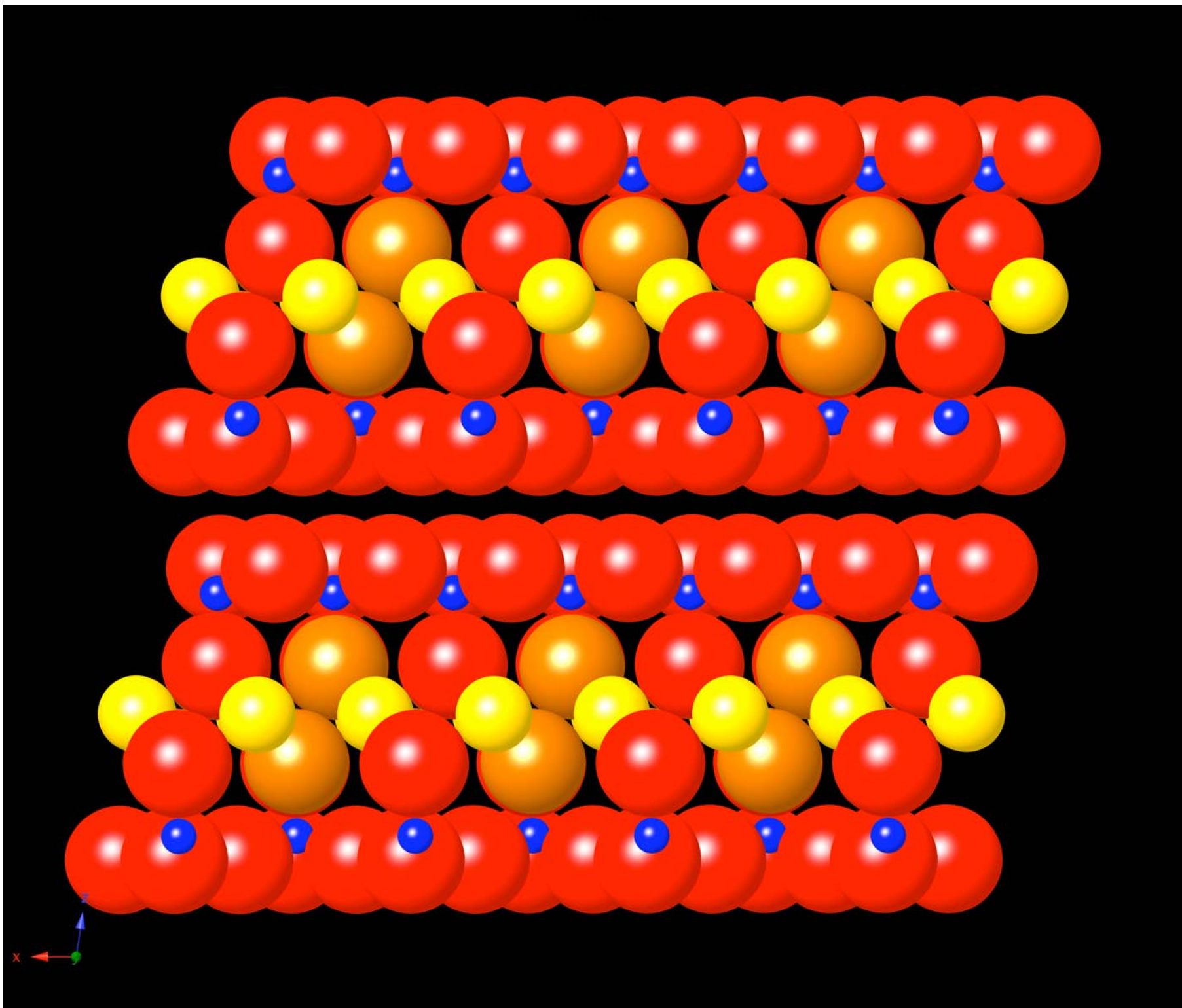

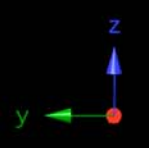
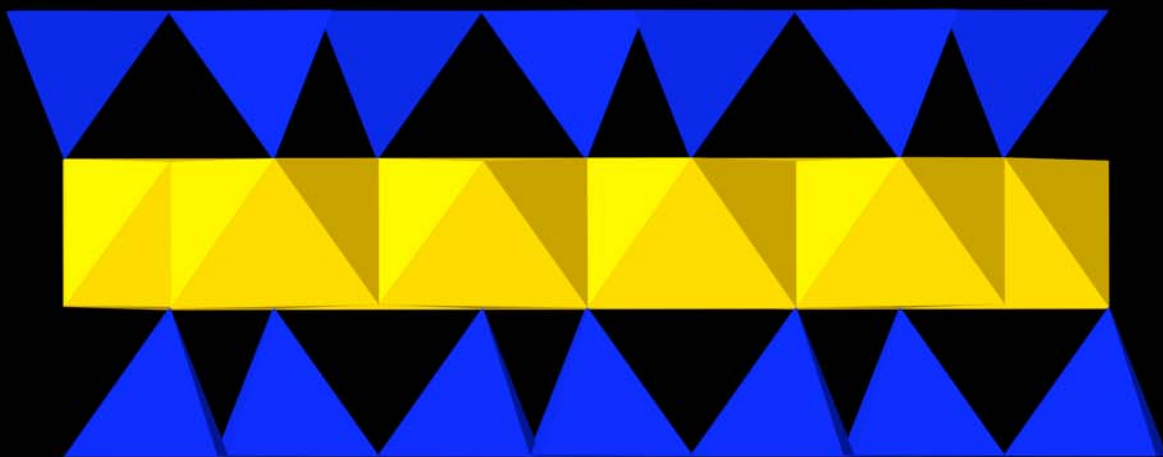
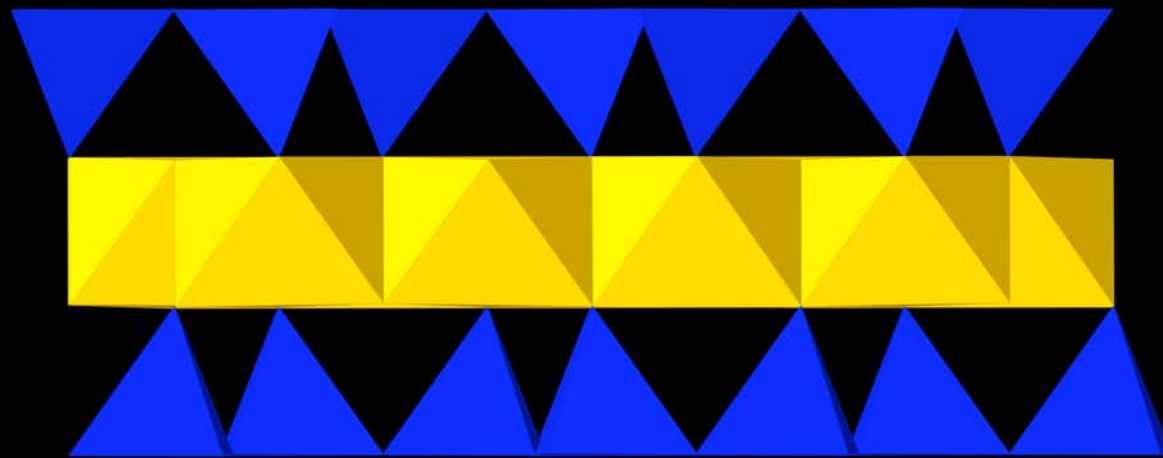

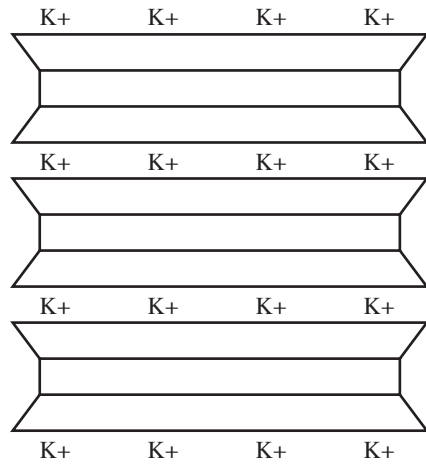

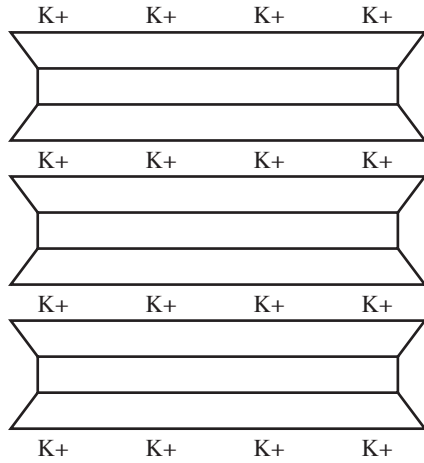

Phlogopite



Annite



Clintonite



Siderophyllite



Eastonite



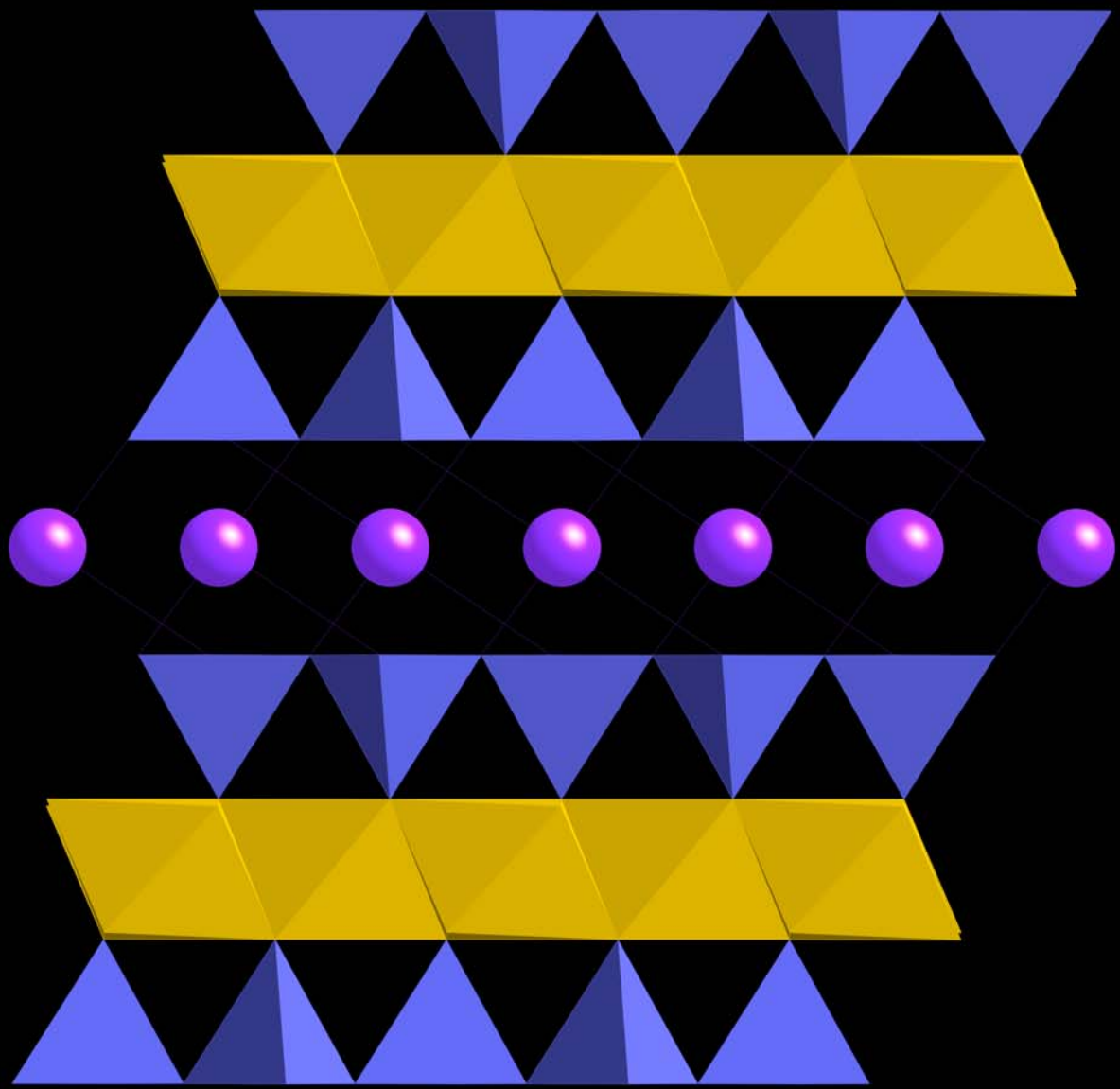

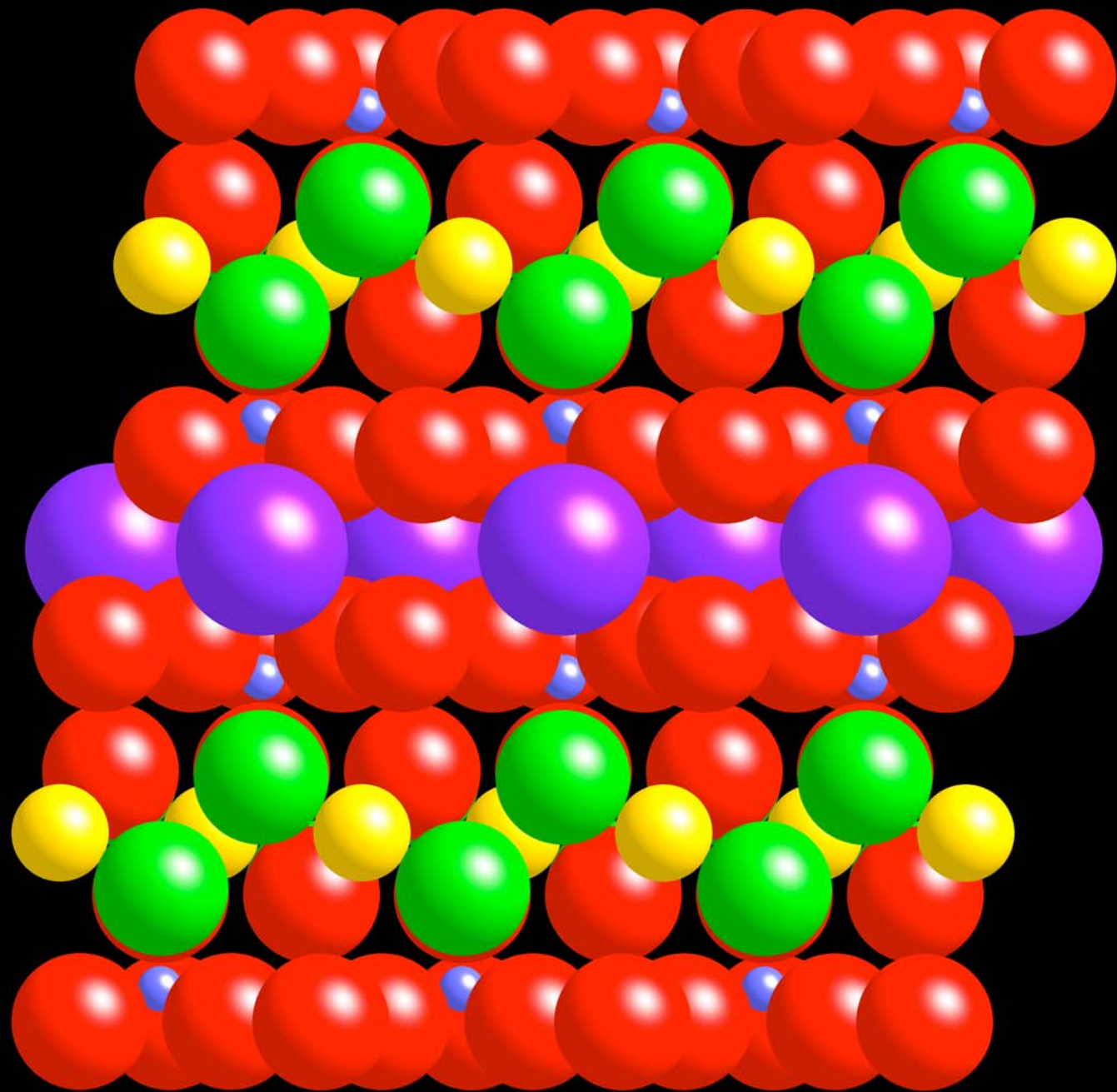

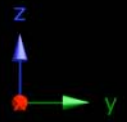
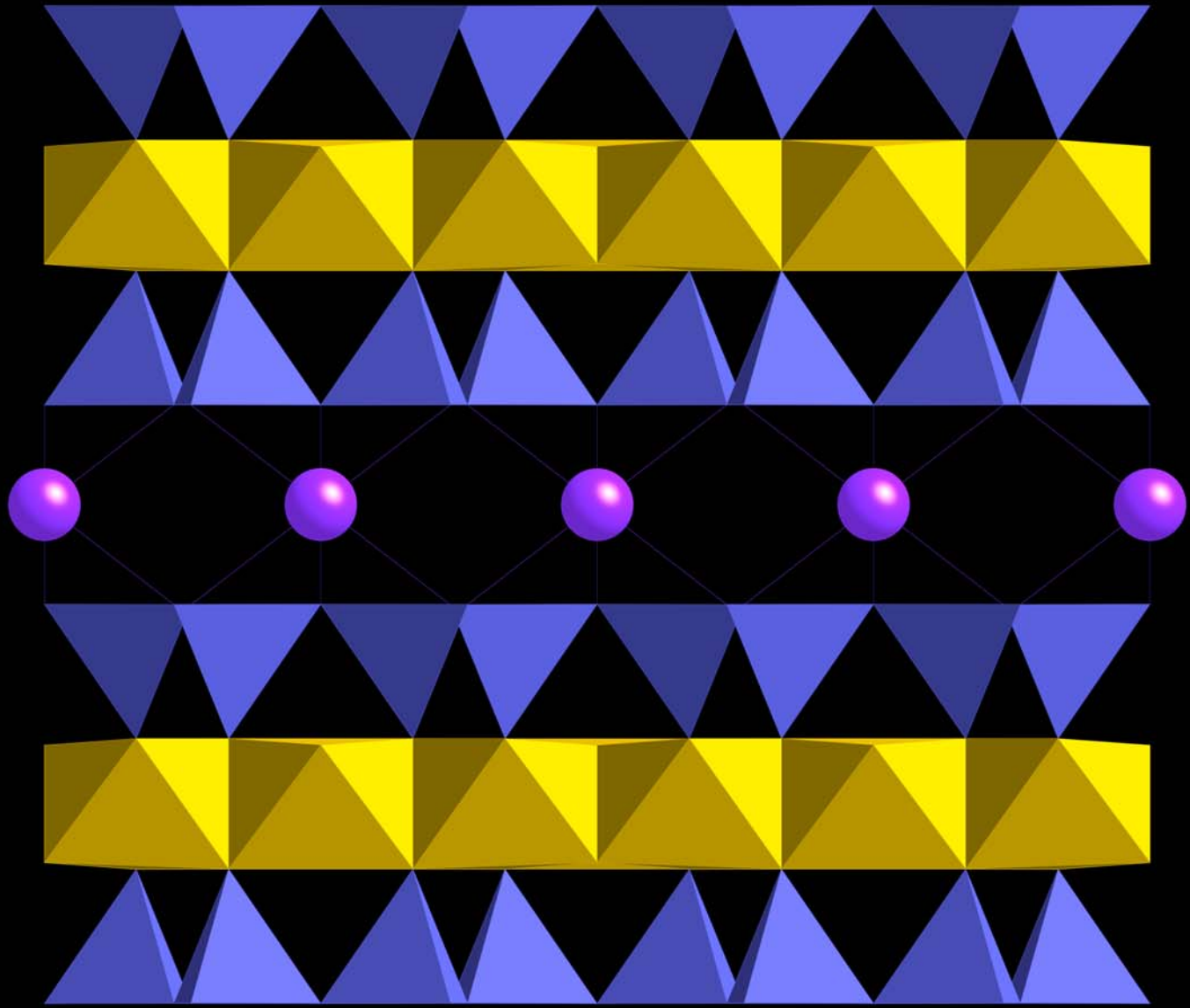

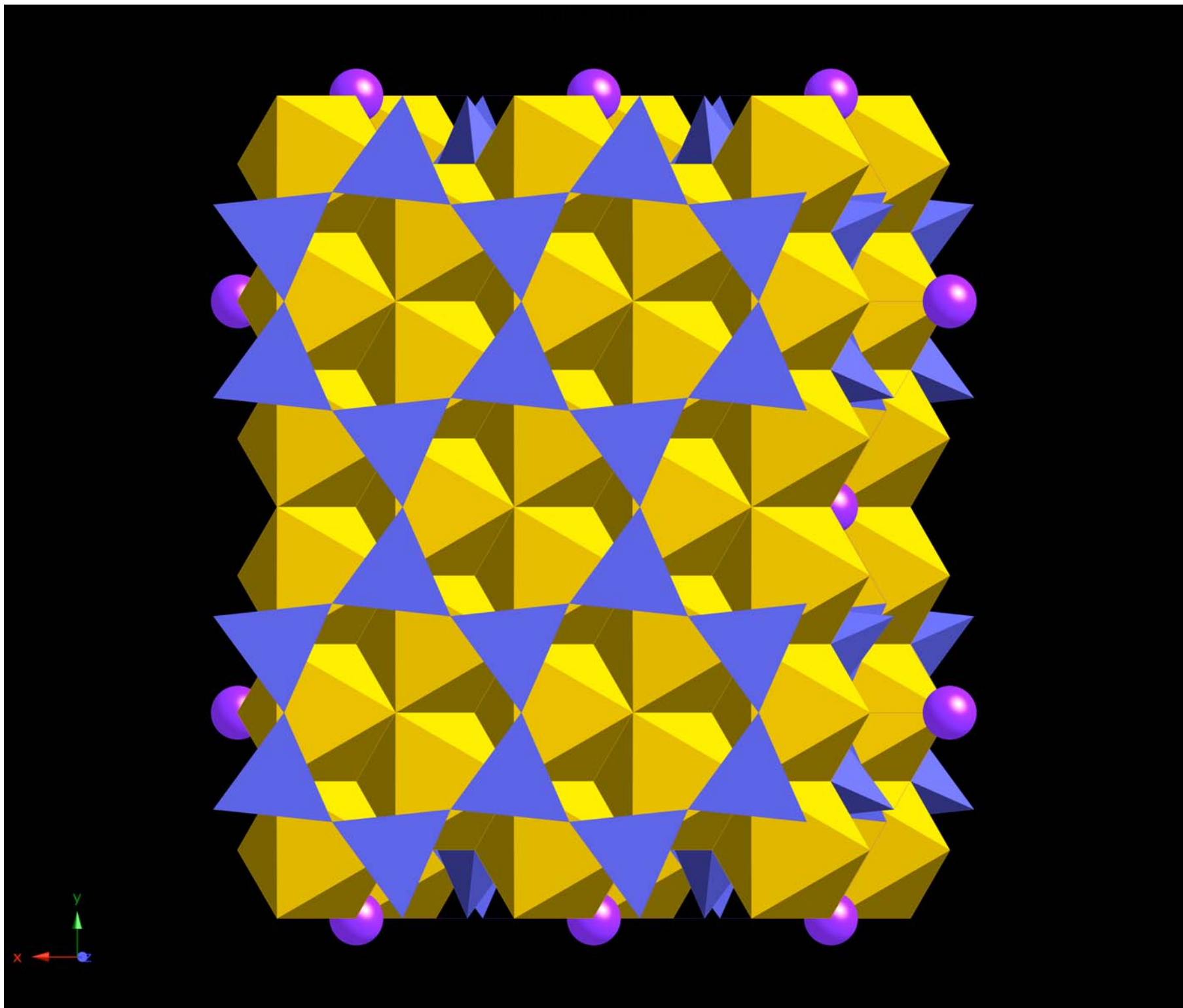

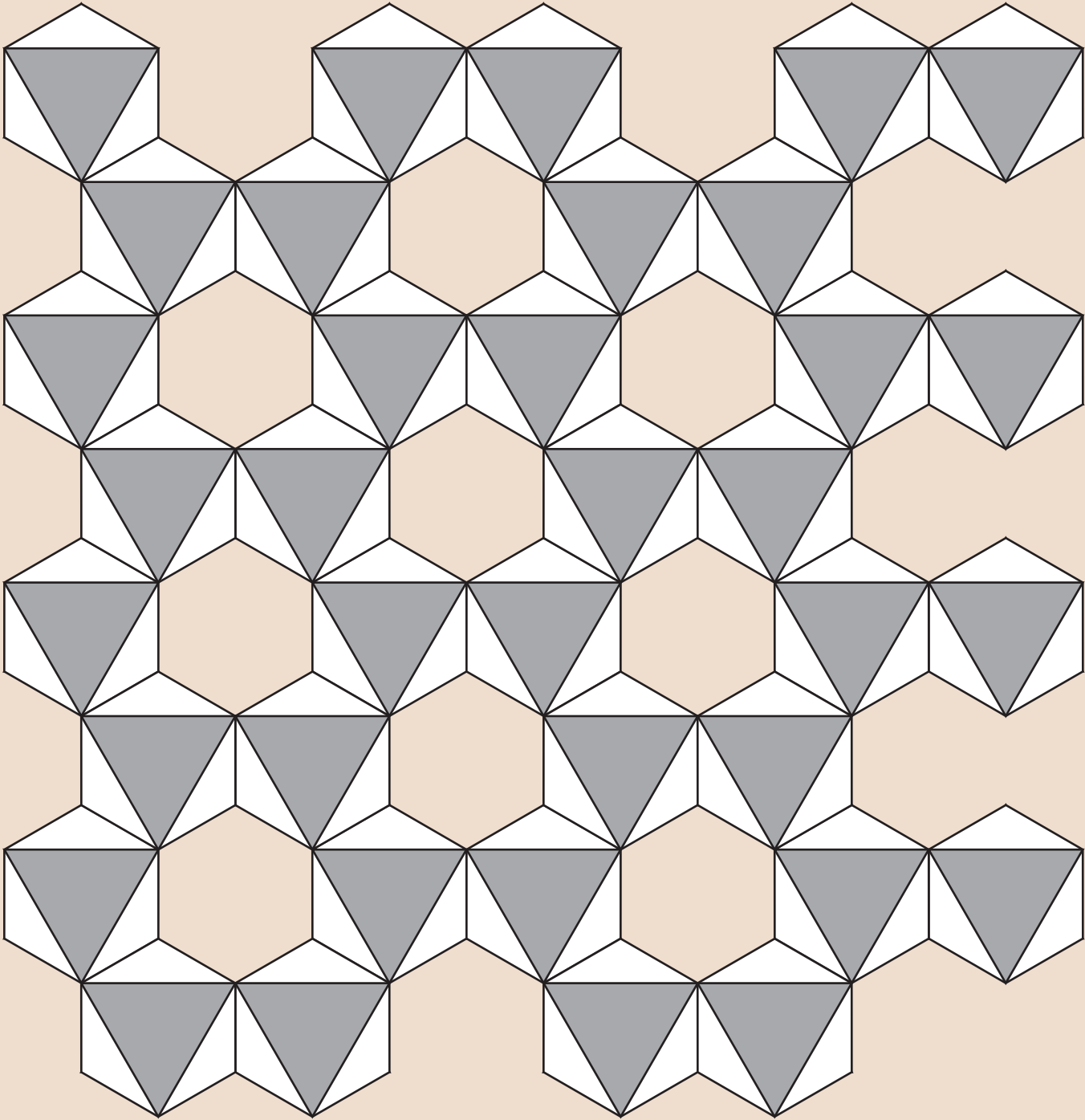

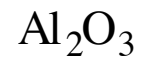
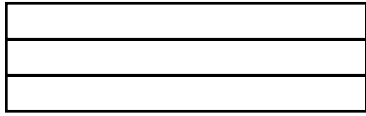

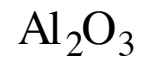
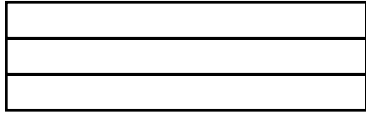

Corundum

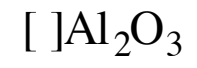

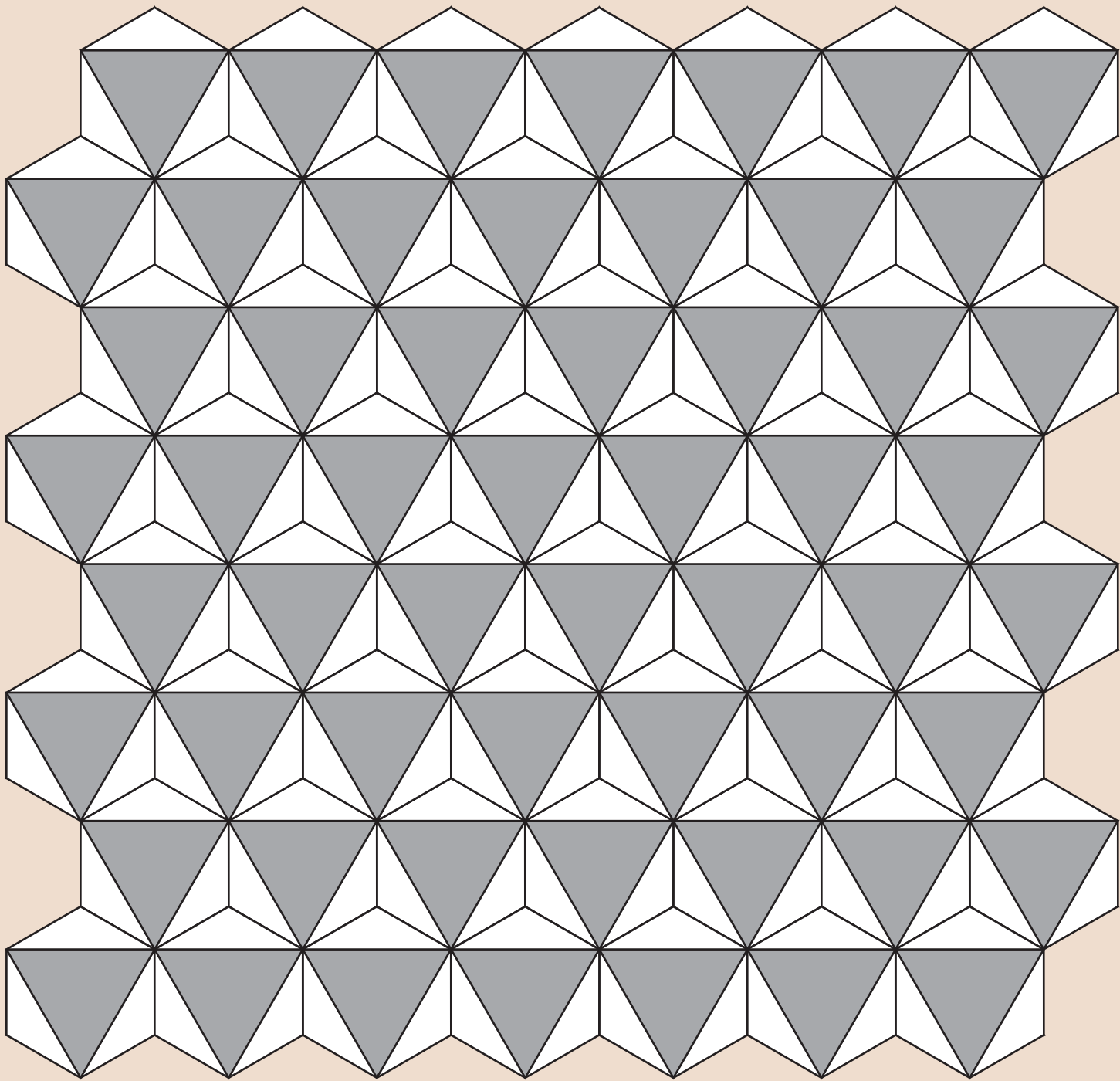

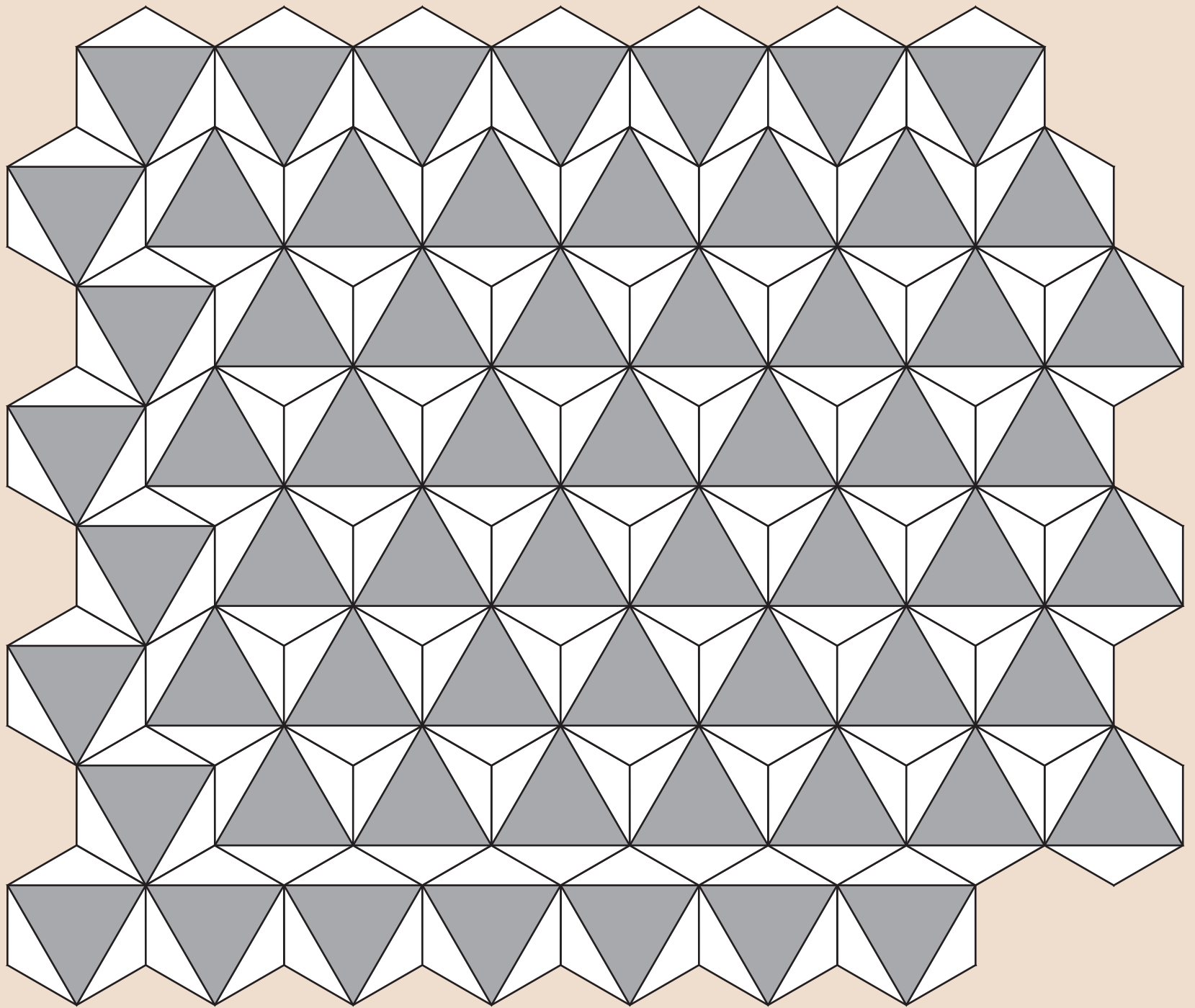

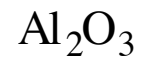
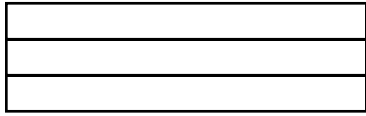

Corundum

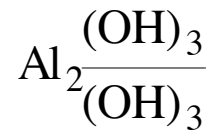
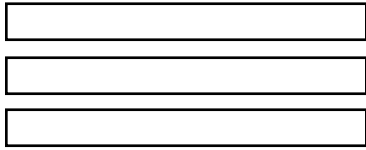
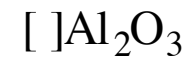

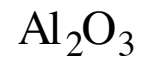
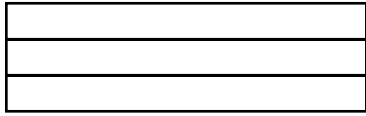

Corundum

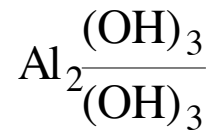
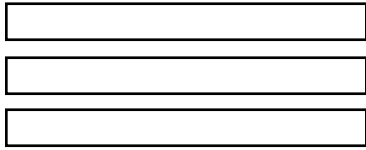
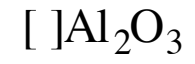

Gibbsite

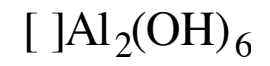

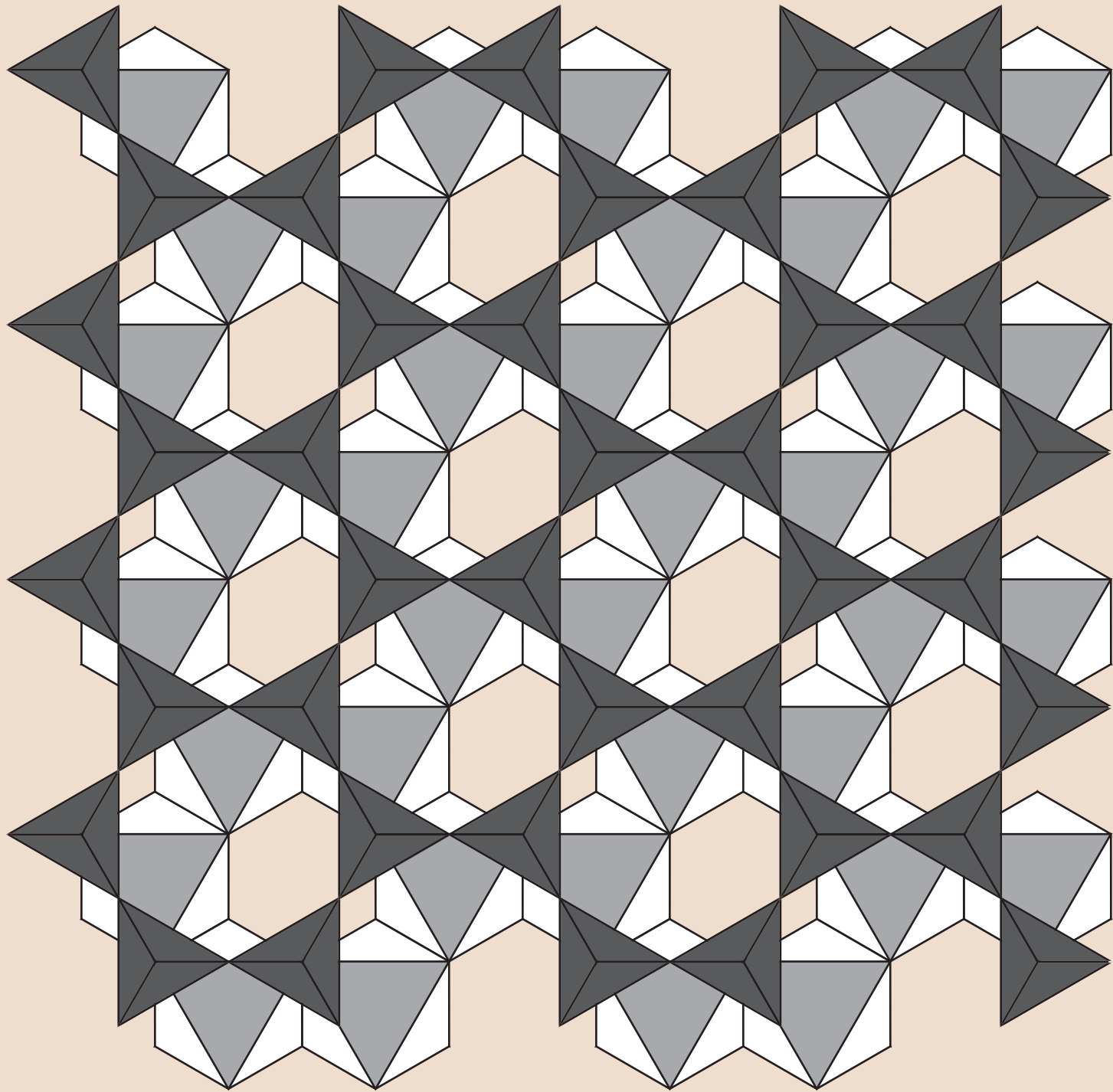

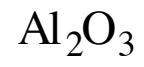
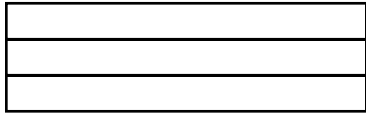

Corundum

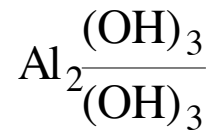
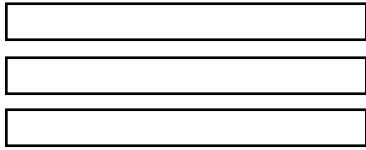
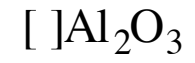

Gibbsite

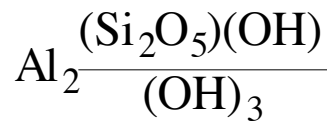
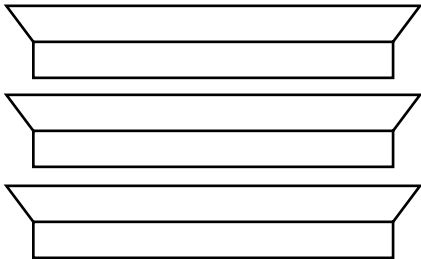
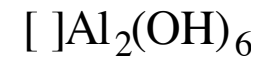

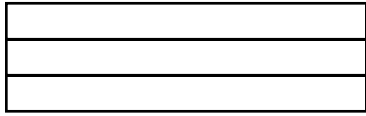

Corundum

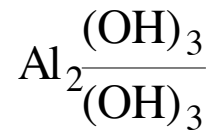
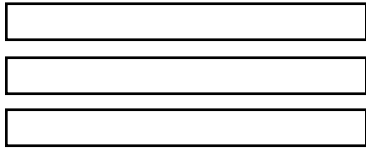
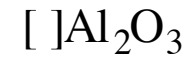

Gibbsite

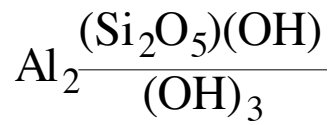
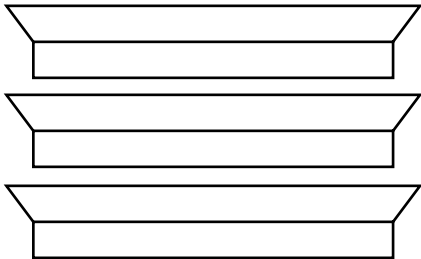
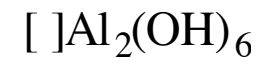

Kaolinite

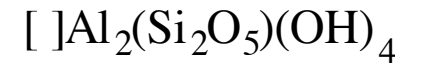

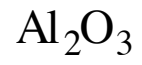
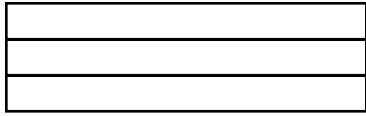

Corundum

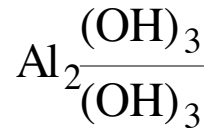
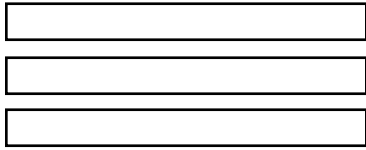
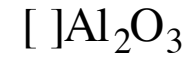

Gibbsite

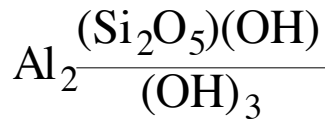
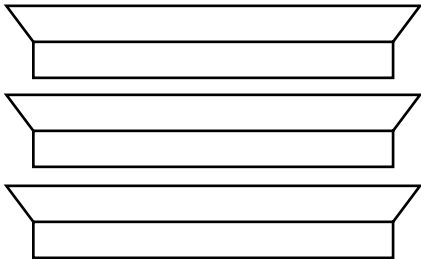
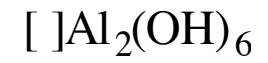

Kaolinite

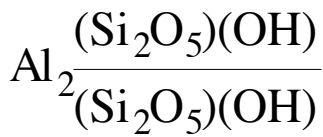
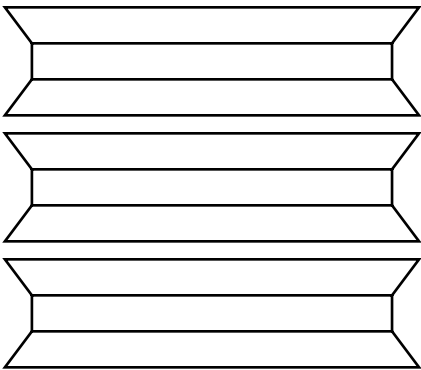
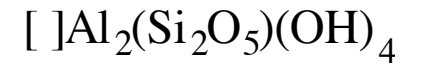

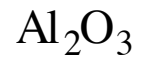
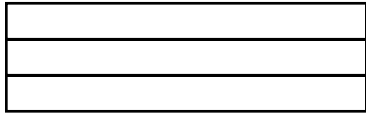

Corundum

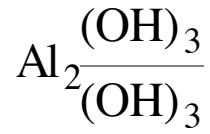
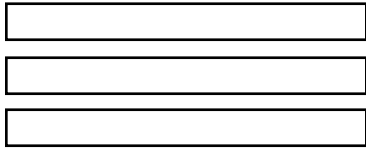
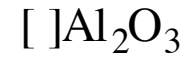

Gibbsite

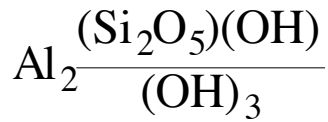
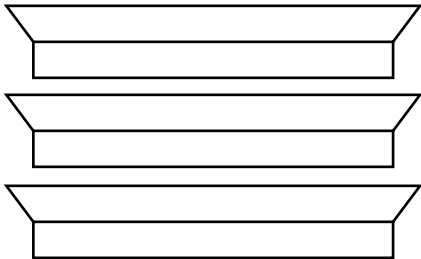
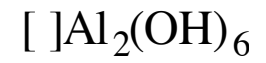

Kaolinite

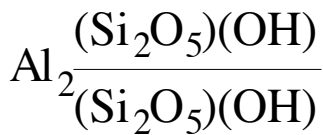
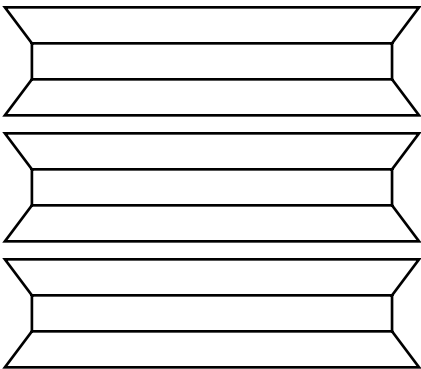
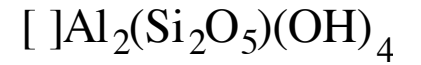

Pyrophyllite

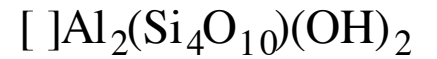

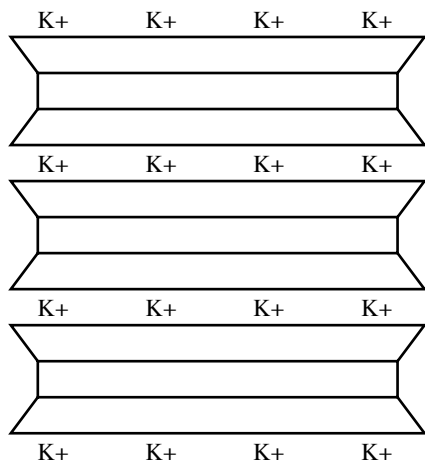

Muscovite

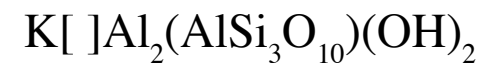

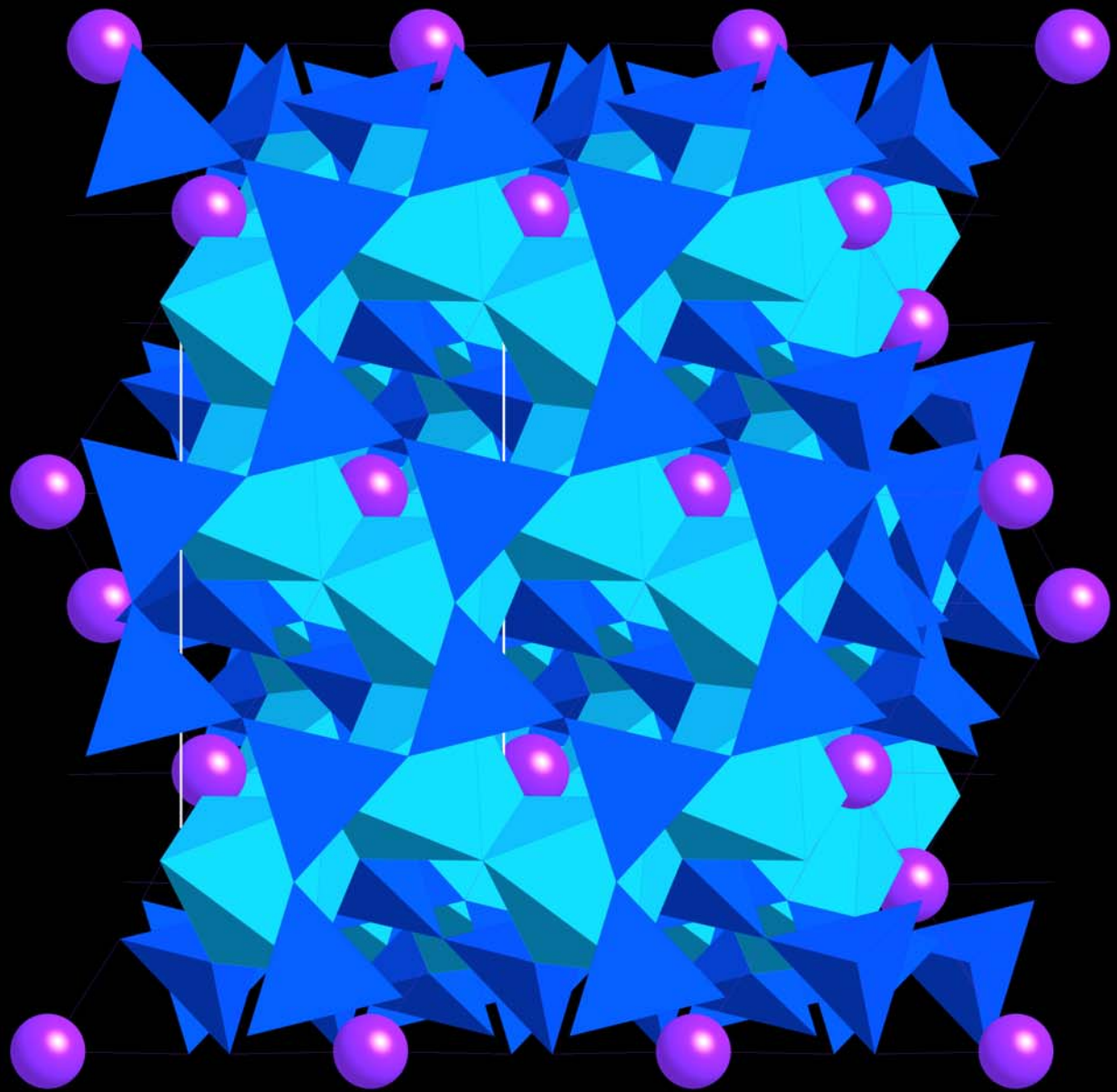

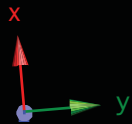
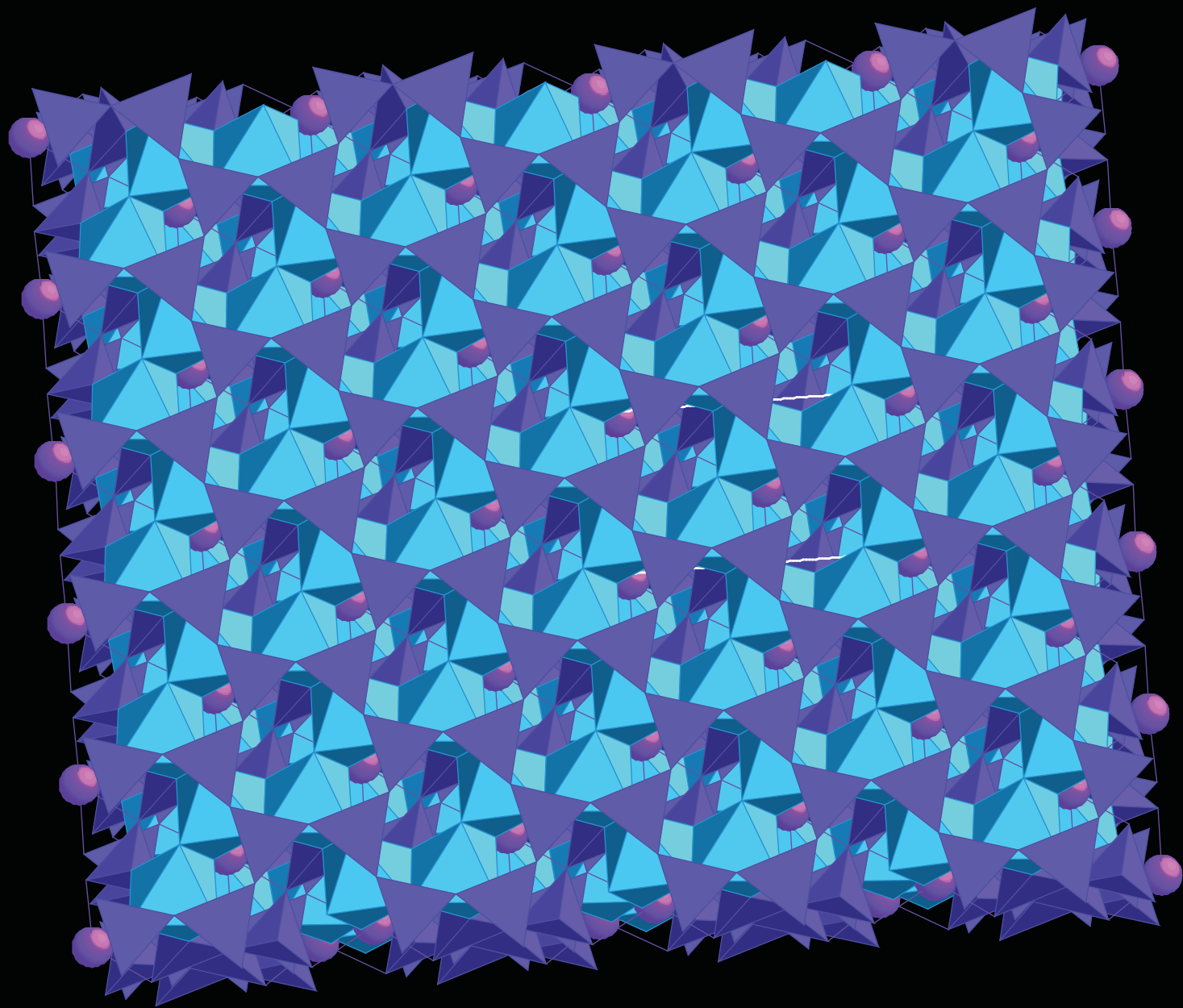

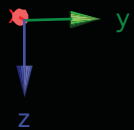
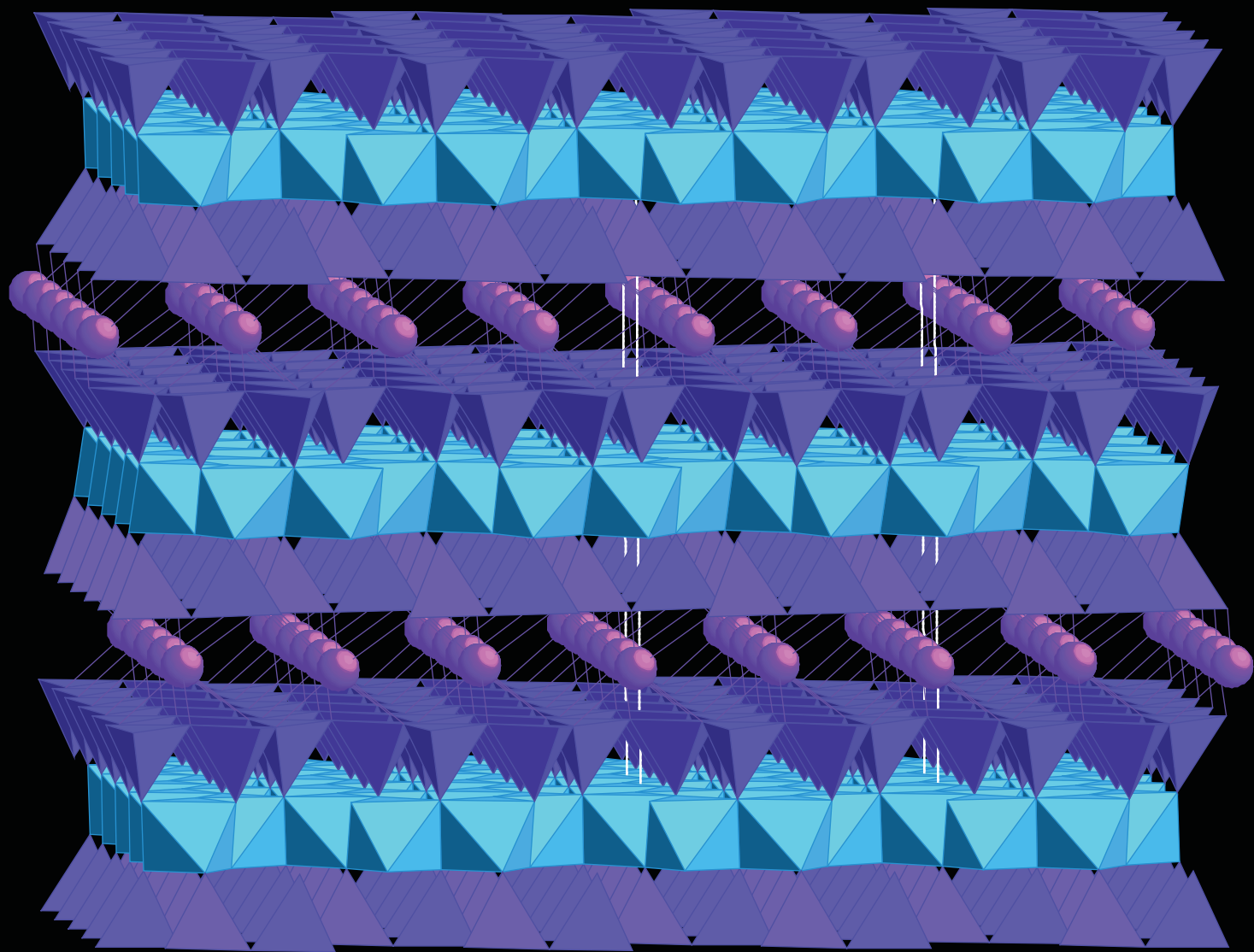

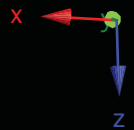
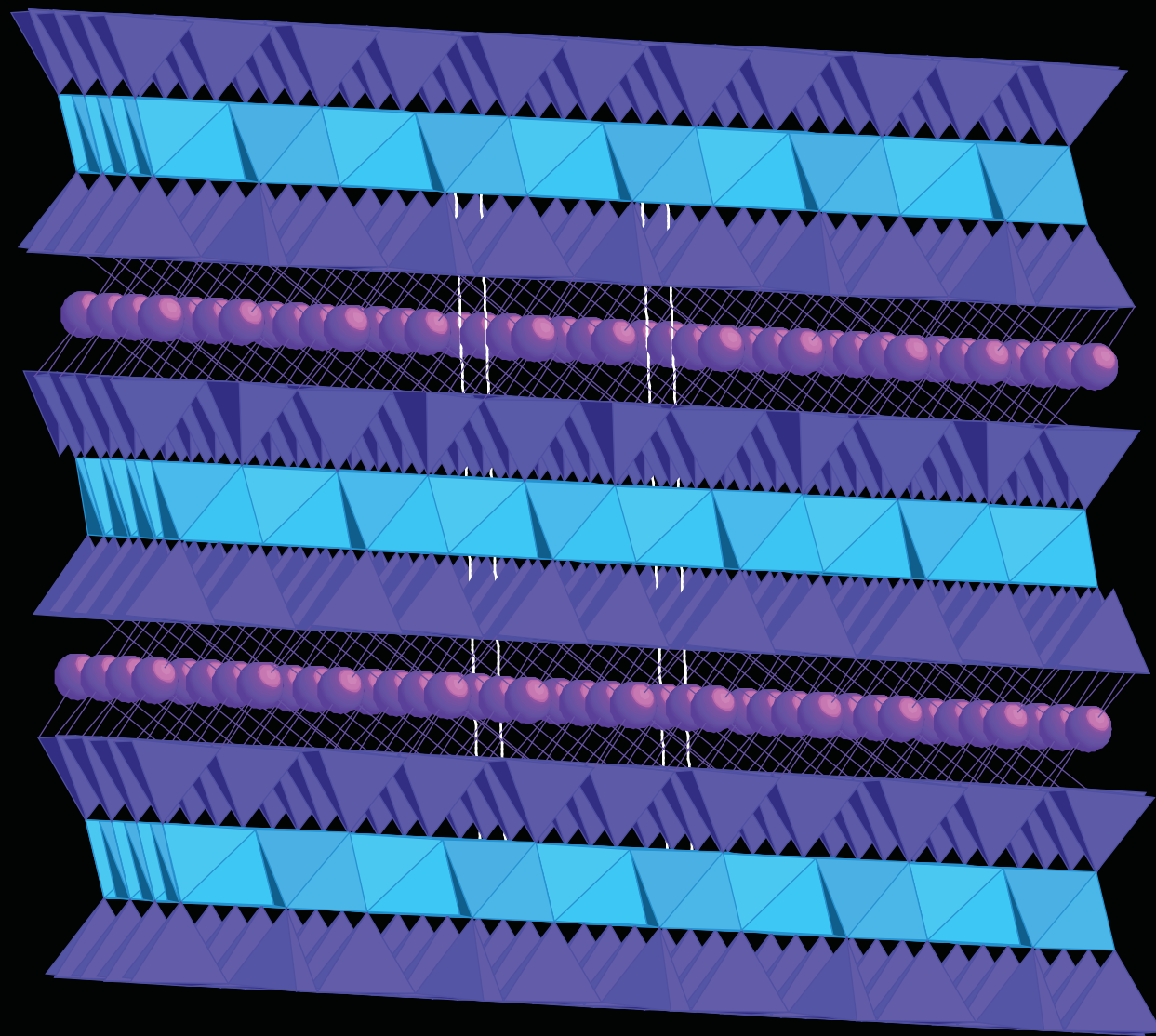

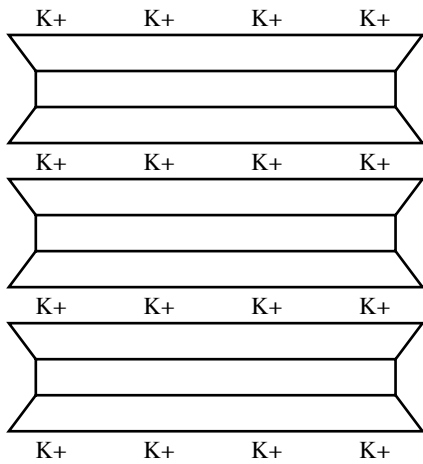

Muscovite

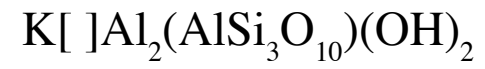

Paragonite



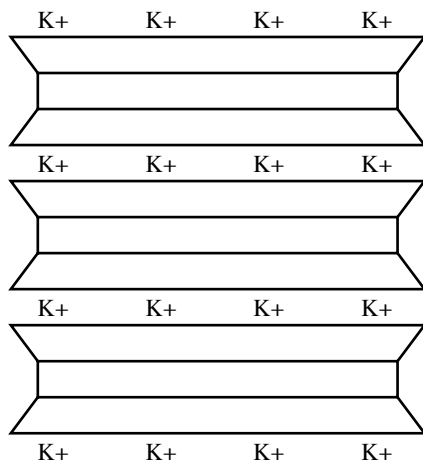

Muscovite



Paragonite



Margarite

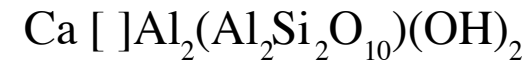

Lepidolite

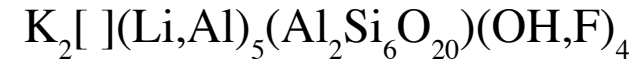

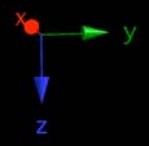
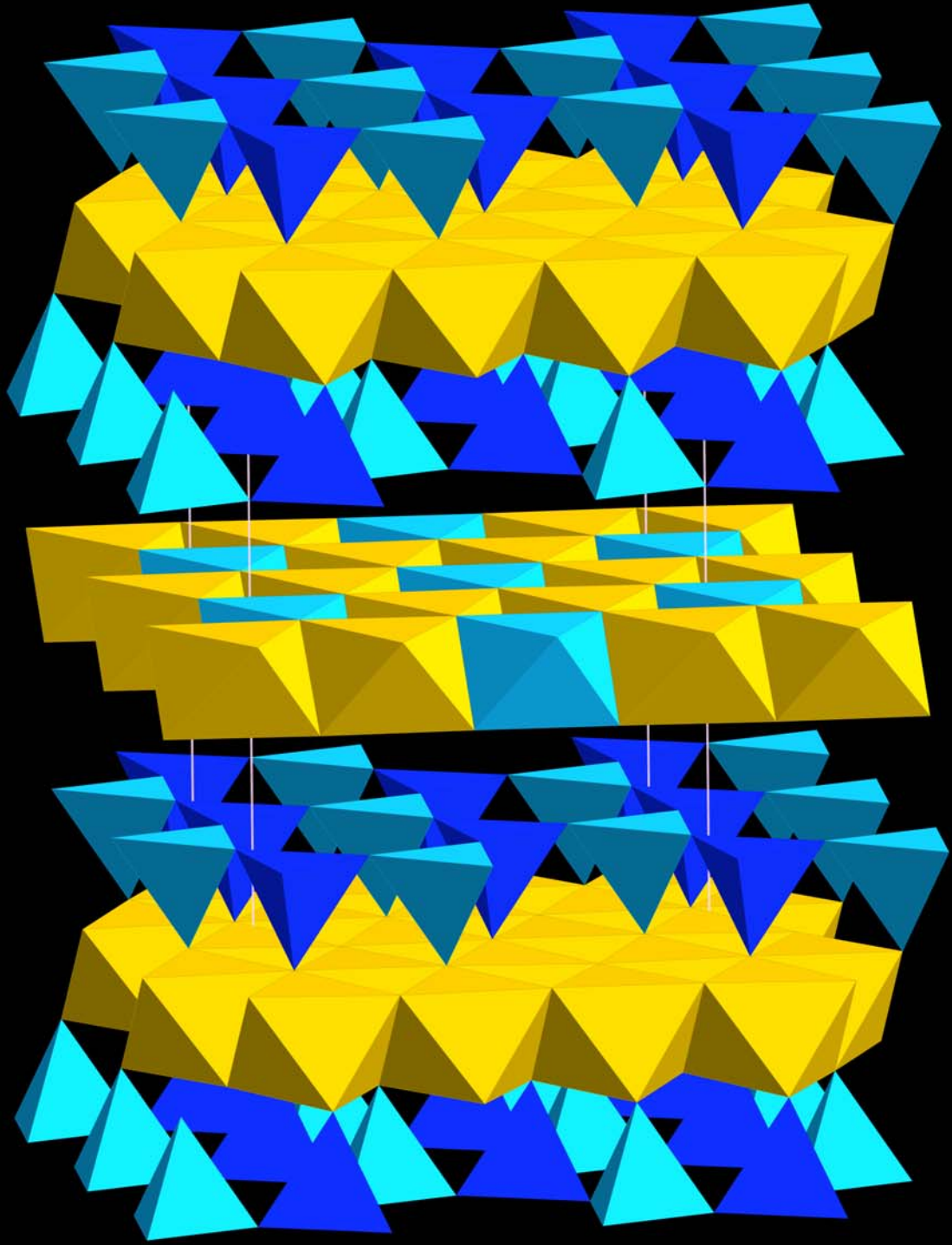

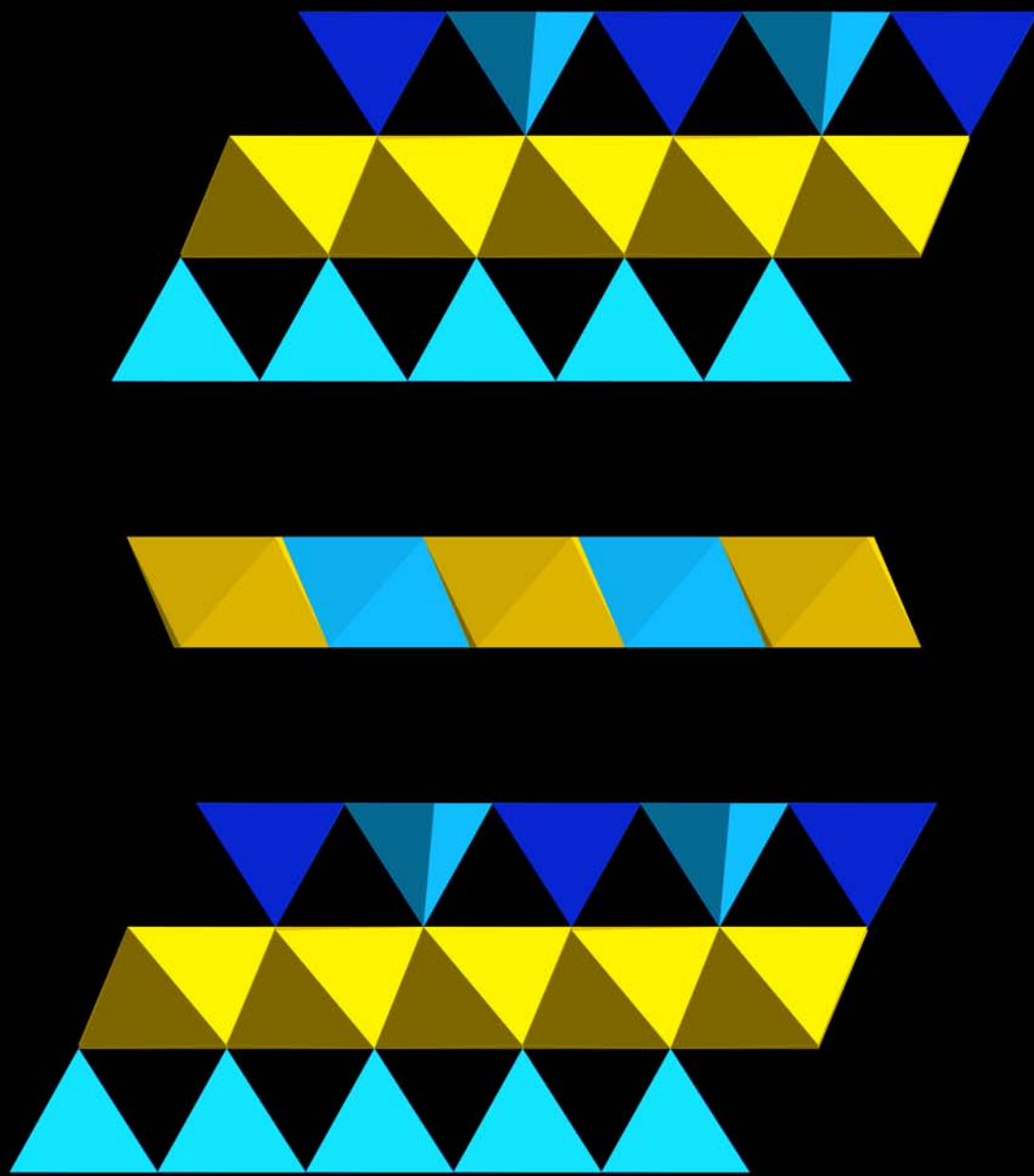

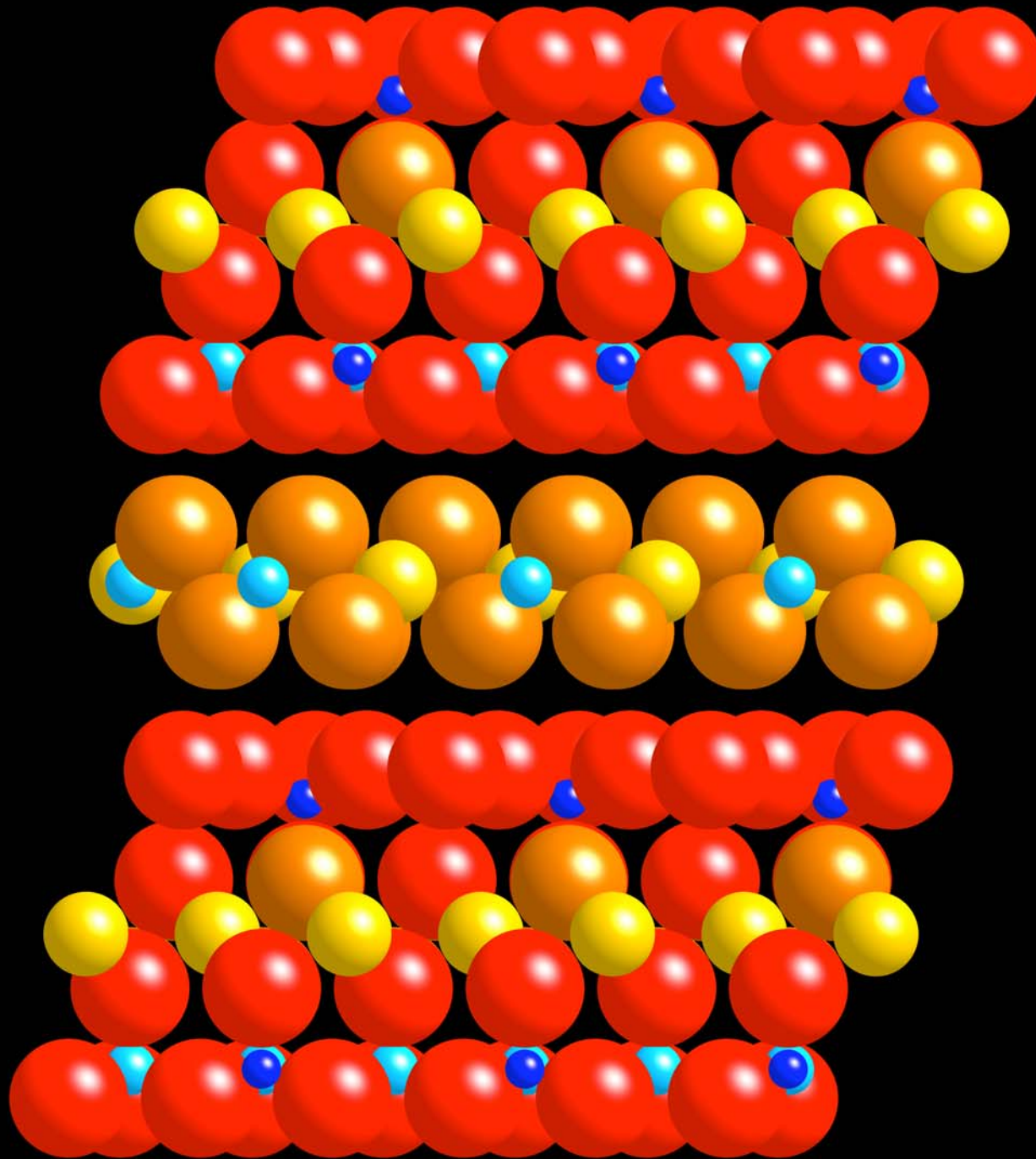

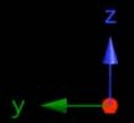
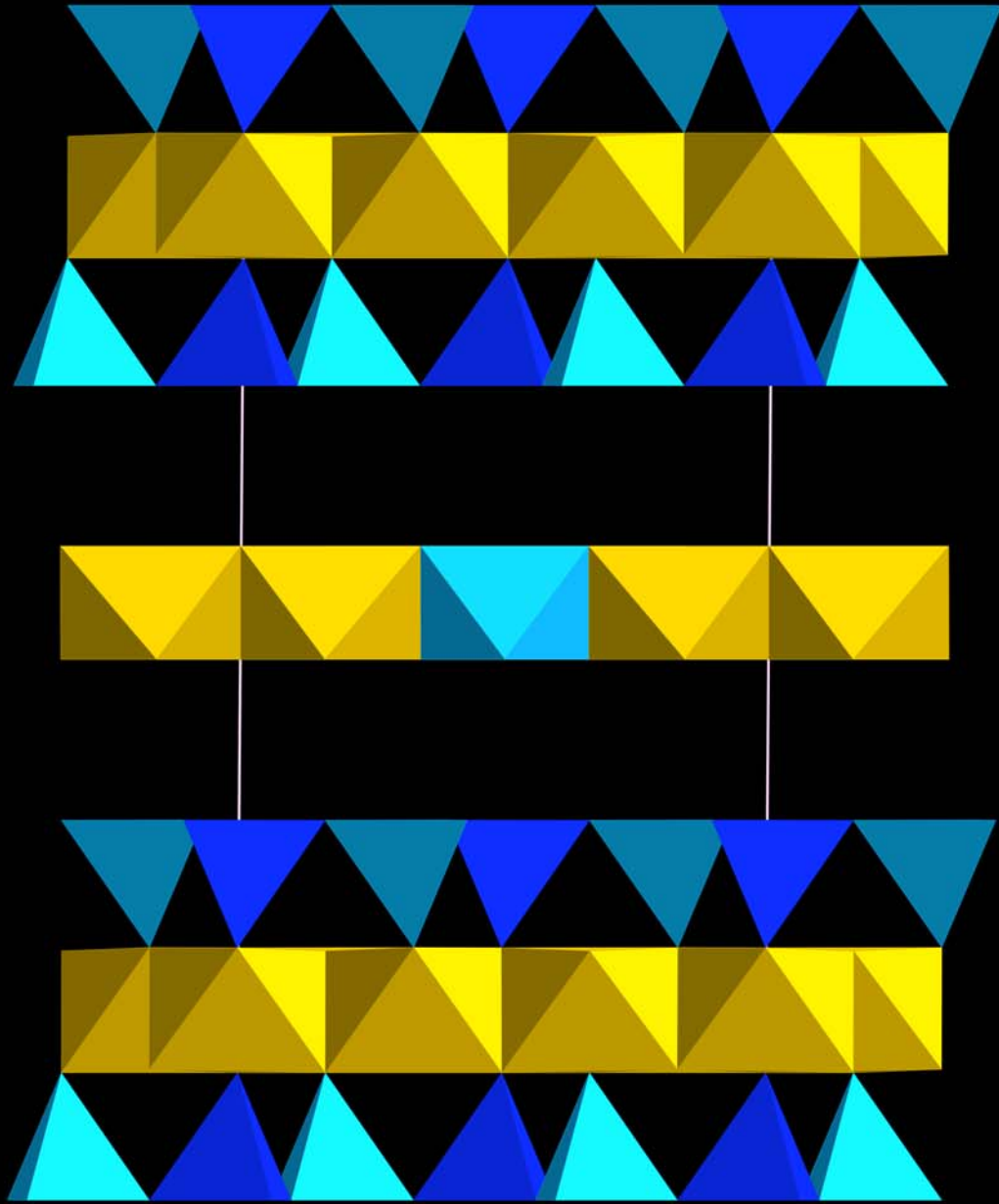

0.2 mm

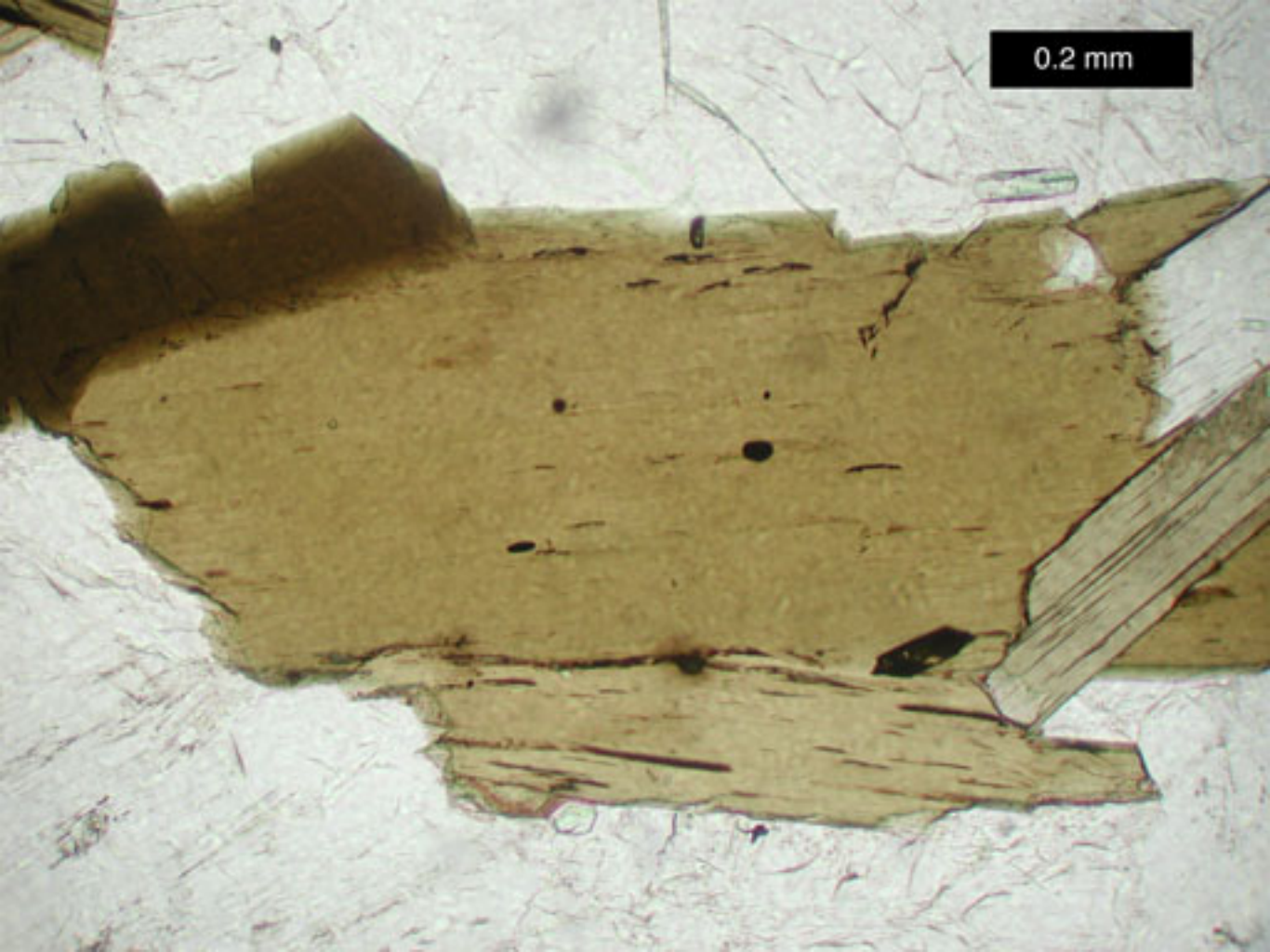

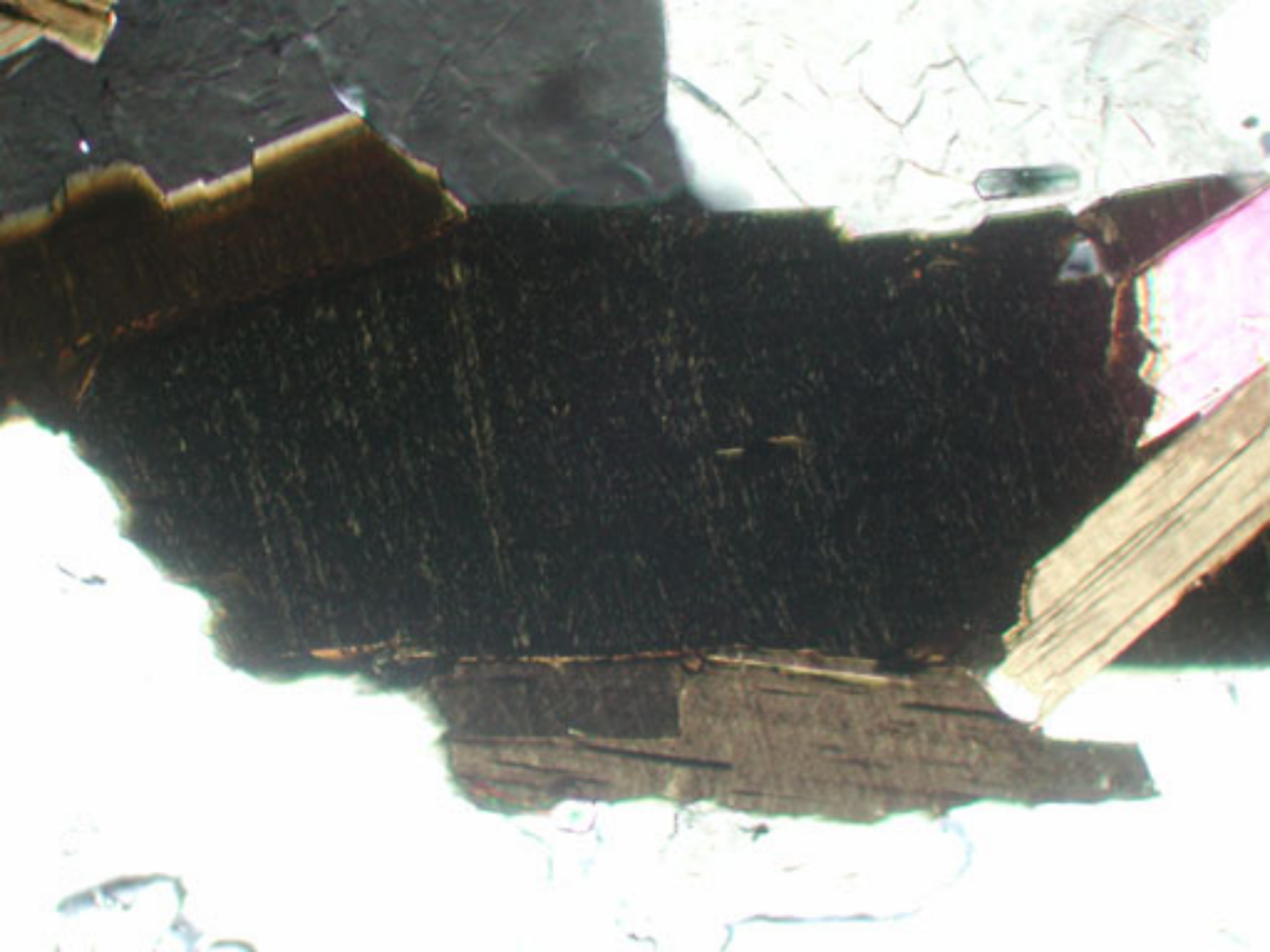

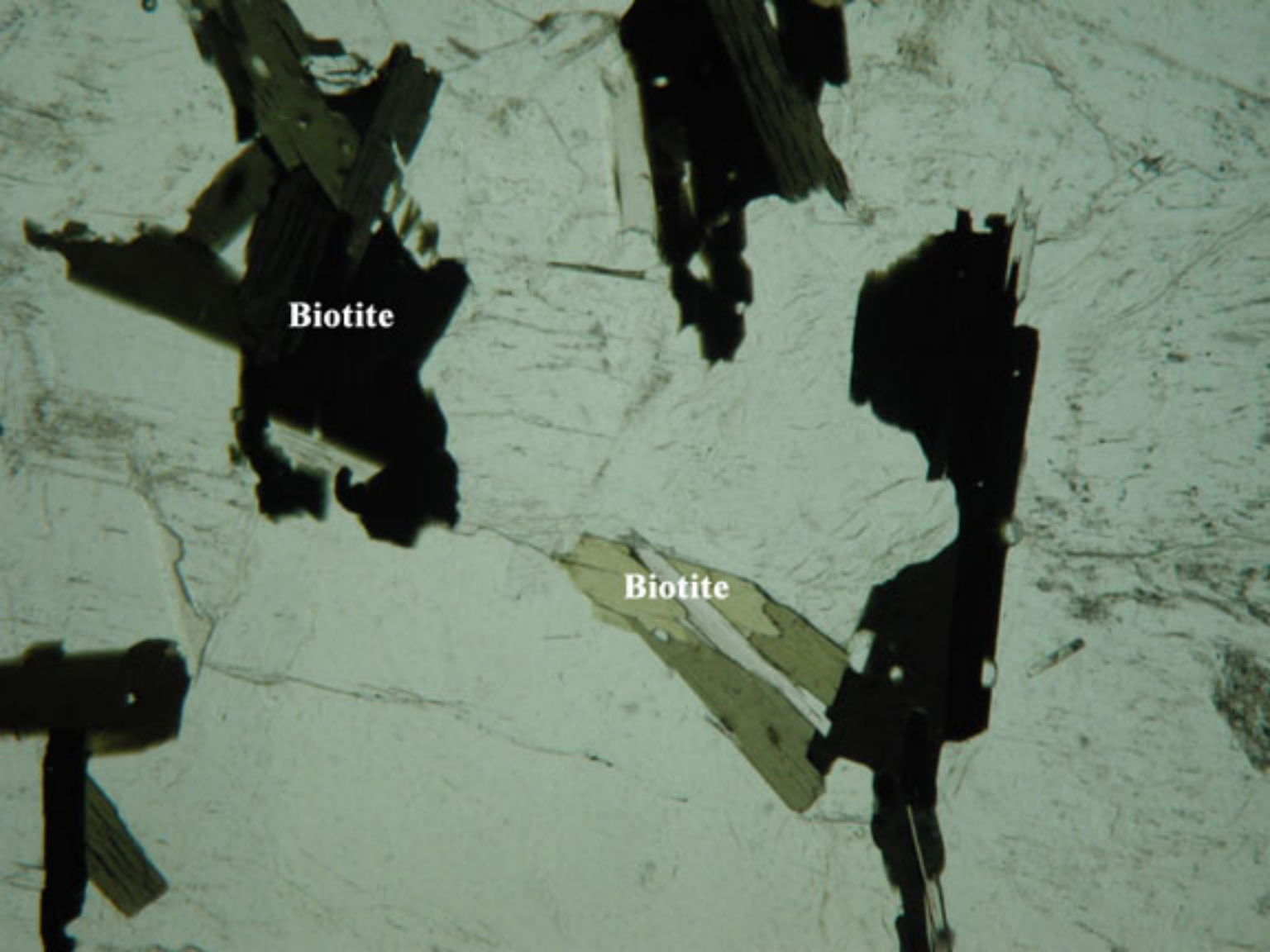
A photomicrograph showing several dark, irregularly shaped Biotite crystals embedded in a light-colored, textured matrix. The crystals exhibit various orientations and sizes, with some showing distinct cleavage patterns. The matrix has a fine, fibrous or crystalline texture. Two specific crystals are highlighted with white text labels.

Biotite

Biotite

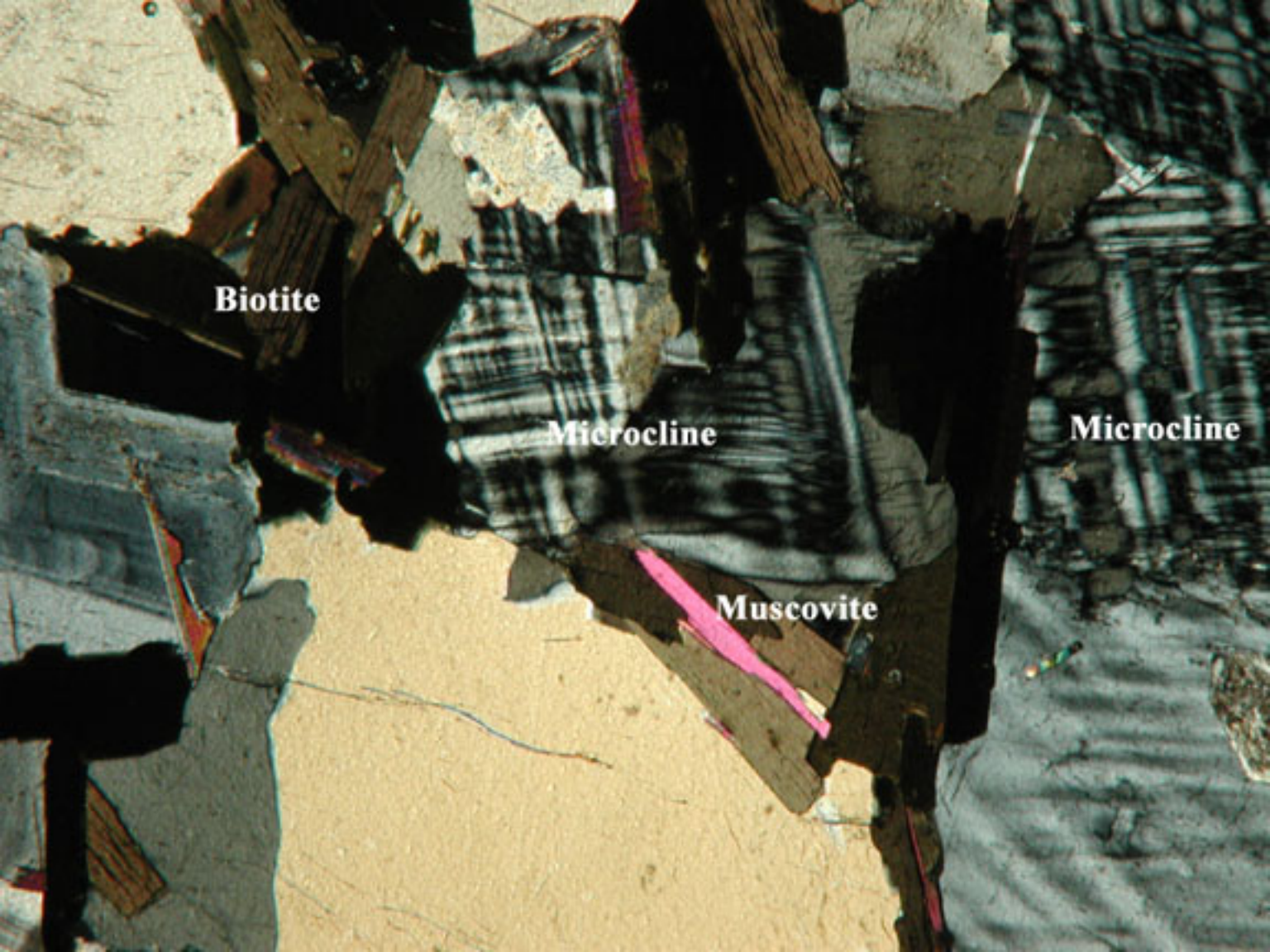

A polarized light micrograph of a rock thin section. The image shows several distinct mineral grains with different textures and colors. A large, dark, irregularly shaped grain is labeled 'Biotite'. Two large, light-colored, rectangular grains with a grid-like internal texture are labeled 'Microcline'. A smaller, elongated, pinkish grain is labeled 'Muscovite'. The background consists of a fine-grained, light-colored matrix. The lighting is polarized, creating bright and dark areas within the grains.

Biotite

Microcline

Microcline

Muscovite

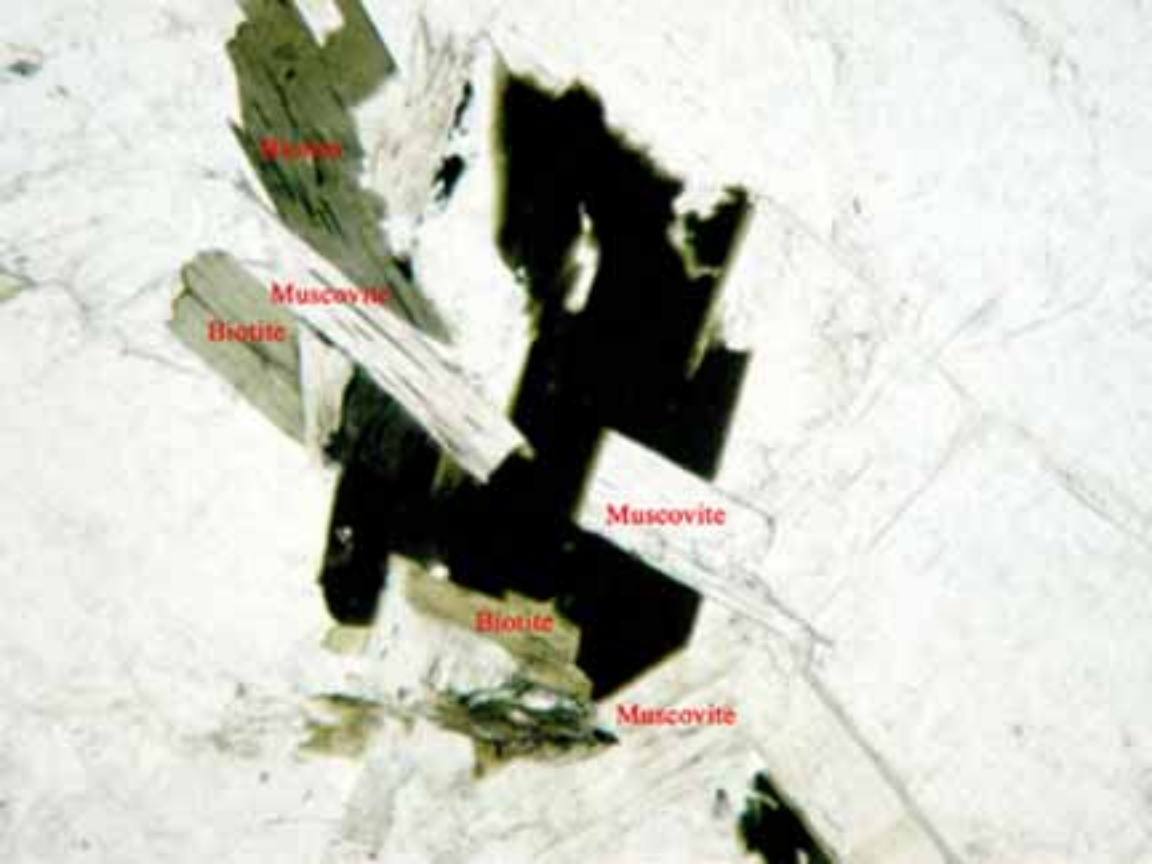

Quartz

Muscovite

Biotite

Muscovite

Biotite

Muscovite

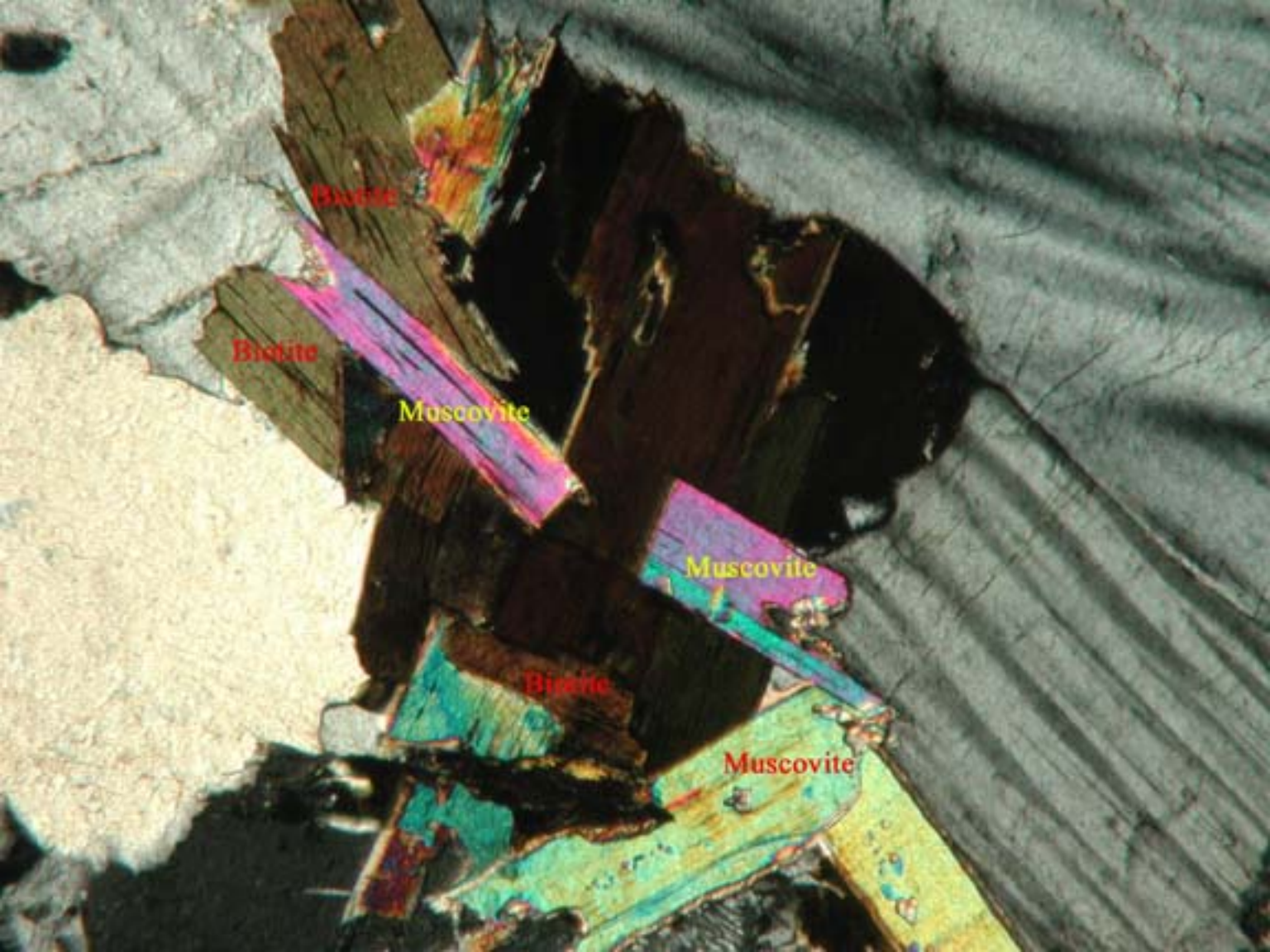

Biotite

Biotite

Muscovite

Muscovite

Biotite

Muscovite

<-- Muscovite

Feldspar -->

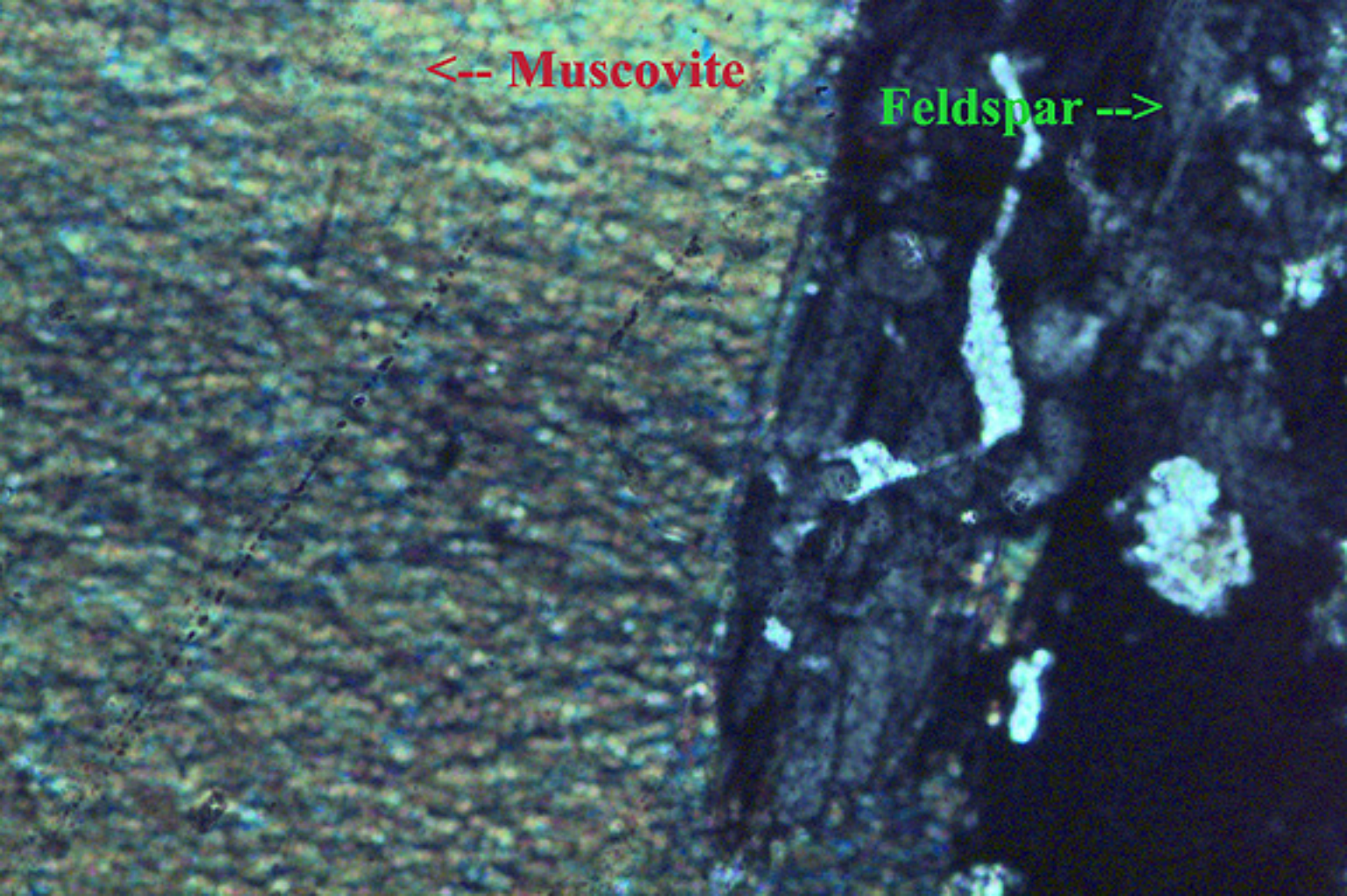

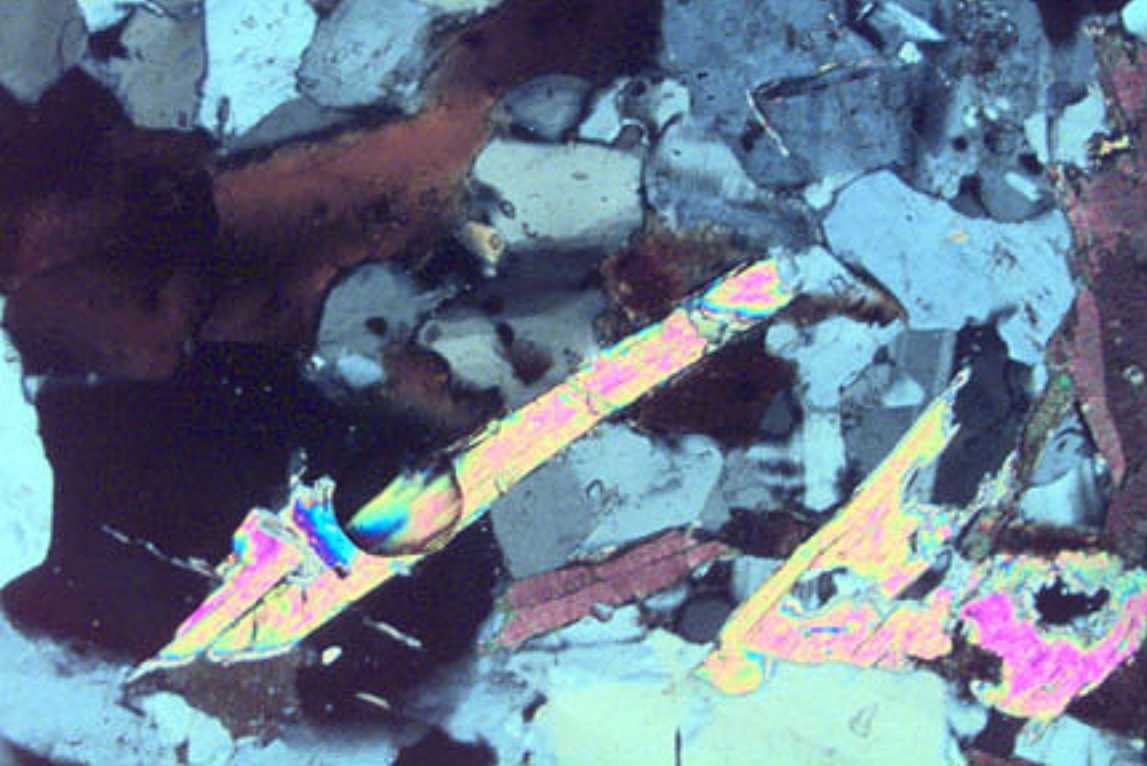

Muscovite

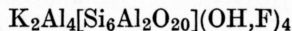

MONOCLINIC (-)

α	1.552-1.574
β	1.582-1.610
γ	1.587-1.616
δ	0.036-0.049
$2V_\alpha$	30°-47°

$\alpha : z = 0^\circ - 5^\circ, \beta : x = 1^\circ - 3^\circ$

$\gamma = y, \text{ O.A.P. } \perp (010)$

Dispersion : $r > v$

D 2.77-2.88

H $2\frac{1}{2}$ -3

Cleavage : {001} perfect.

Twinning : Composition plane {001}, twin axis [310].

Colour : Colourless, or light shades of green, red or brown ; colourless in thin section.

Pleochroism : Weak ; absorption greater for vibration directions in the plane of cleavage.

Unit cell : The most common polymorph has
 a 5.19, b 9.04, c 20.08 Å, β 95° 30'.

$Z=2$. Space group $C2/c$.

Insoluble in acids.

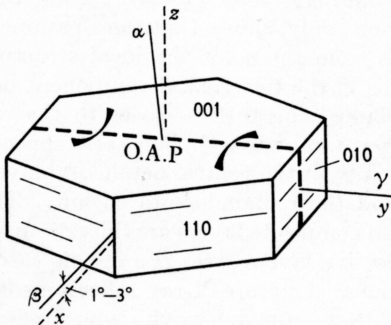

Biotite

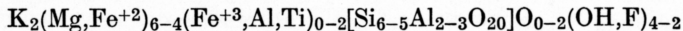

MONOCLINIC (-)

α	1.565-1.625
β	1.605-1.696
γ	1.605-1.696
δ	0.04-0.08
$2V_\alpha$	$0^\circ-25^\circ$

$\gamma: x = 0^\circ$ to 9°

$\beta = \gamma$; O.A.P. (010)

Dispersion: Weak:

Fe-rich biotites $r < v$

Mg-rich biotites $r \geq v$

D 2.7-3.3

H $2\frac{1}{2}-3$

Cleavage: {001} perfect.

Twinning: Composition plane {001}, twin axis [310].

Colour: Black, deep shades of brown, reddish brown or green; yellow, brown or green in thin section.

Pleochroism: Strong;

α greyish yellow, brownish green or brown;

$\beta = \gamma$ dark brown, dark green or dark reddish brown.

Unit cell: a 5.3, b 9.2, c 10.2 Å, β 100° .

$Z=1$. Space group Cm (1M polymorph).

Bleached and attacked by sulphuric acid.

