

Mineralogy Problem Set

Crystal Systems, Crystal Classes

- (1) For each of the five numbered wooden blocks:
 - (a) Identify the crystal system;
 - (b) Identify the crystal class;
 - (c) List the **forms** present.

- (2) Determine the axial ratios (**a:b:c**) for the mineral **celestite** using the crystals and goniometers (contact or reflection) available in the lab. Please show all of your calculations and reference them to cross-section diagrams of the crystal(s) measured. Draw carefully. Make your diagrams accurate. Be sure to label all faces with the appropriate Miller indices on your diagrams. Celestite has an orthorhombic unit cell with $\alpha = \beta = \gamma = 90^\circ$. It is isostructural with barite, with similar crystal forms. The most common faces are *c* (001), *m* (210), *o* (011), and *d* (101). You may also see *b* (010) or *l* (102). See attached diagram.

- (4) Real crystals are rarely as perfect as models. The symmetry of their shapes does not always match their crystal class because of the circumstances of crystal growth. Nevertheless, the angles between faces must be consistent with the mineral's crystal system. Some good natural crystals are also in the tray with the wooden blocks. Determine the crystal system for each of the eight examples of real crystals (149, 602, 1101, 2502, 2506, 2807, 2837).

- (5) Use the computer program SHAPE to draw an ideal crystal that matches a drawing in a textbook that includes at least 3 forms. Use the actual unit cell of the mineral as data for the SHAPE program. Make a print of your crystal and data to hand in. Be sure to label the print with Miller Indices for the faces shown. Color the forms with different colors. Also, give the Figure and Page numbers of the figure in the book (and the title of the book) you are matching, or better yet attach a Xerox copy of the book figure.

Celestite (SrSO₄)

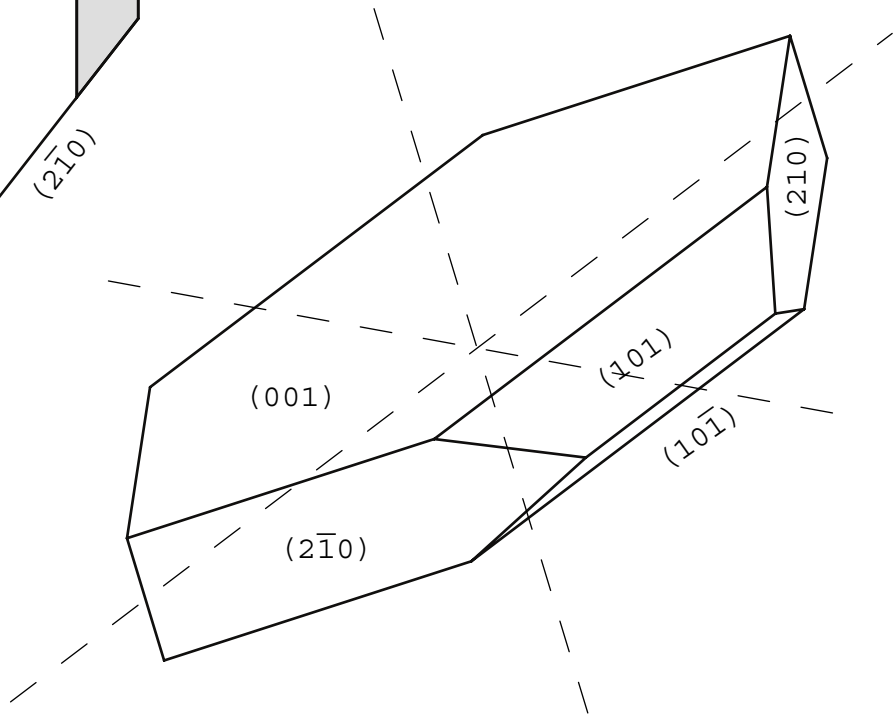
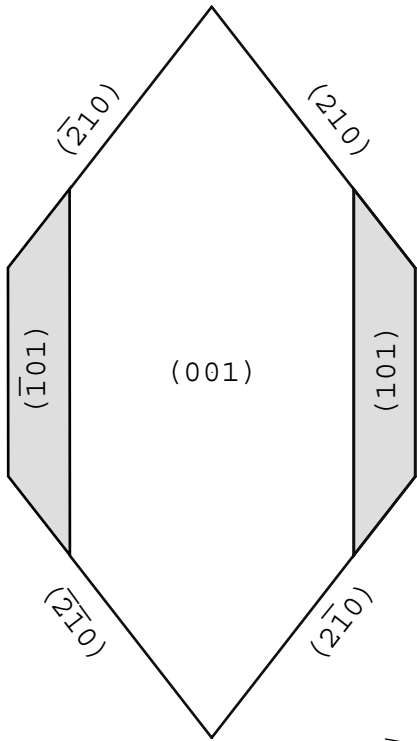

Common faces:

- c* (001)
- m* (210)
- o* (011)
- d* (101)
- b* (010)
- l* (102)

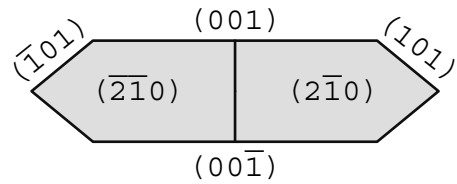

Using the computer program SHAPE

SHAPE is a computer program that draws crystal shapes according to instructions input by the user. The user specifies: 1) a crystal class (thus specifying the symmetry of the crystal); 2) the lengths of the crystallographic axes and the angles between them (except in cases where these are automatically determined by the symmetry of the crystal class); 3) the Miller indices of one or more forms, and the distances of those forms from the center of the crystal. If the user has specified an appropriate combination of forms, the program will generate a closed 3-D crystal shape, which is displayed on the screen (if the combination of forms does NOT produce a CLOSED shape, you will get an error message).

Starting SHAPE:

The SHAPE program lives in the "Geology Applications" folder in the Dock on the Geology Department Macintosh computers. To start SHAPE, double-click on the "SHAPE 7.1" icon.

Entering data:

- From the Start-Up window, choose "New". (Choose "no" in the popup dialog box.)
- The program will ask you for a title for your drawing. Create any title you like.
- Select the crystal system from the pull-down button.
- Enter the lengths of the crystallographic axes, and the angles between them, in the boxes opened by the program when you select the crystal system. If your choice of crystal system automatically determines any these parameters, then the program only ask for those parameters needed (*e.g.* for isometric classes, $\mathbf{a}=\mathbf{b}=\mathbf{c}$, so only \mathbf{a} must be specified, and $\alpha=\beta=\gamma=90^\circ$, so no angles need to be specified).
- Click "OK" when you are done.
- You must specify a crystal class (the "point symmetry"). Choose one of the 32 crystal classes by clicking on the appropriate button. Note that the crystal classes are designated by a notation somewhat different from the standard Hermann-Mauguin symbol (to prevent confusion, a notation conversion chart is attached to these instructions). Be sure to select a crystal class from the crystal system you specified. The program uses the crystal system information only to choose a coordinate system.
- Click "OK" when you are done.
- Now you must enter the Miller indices of forms, one at a time. On the Forms List window that opens, press the "Add" button.

- On the Add/Revise Form window that opens, enter values for **h**, **k**, and **l** (representing the three numbers of the Miller index). Enter also the “Central Distance (the distance from the center of the crystal to the form, measured perpendicular to each face). This tells the program how far the faces should be drawn.
- After each form that you specify, click “OK”. Then click the “Add” button again to enter another form. When you’ve specified all the forms you want, click “OK” instead of “Add”.
- Answer “Yes” to the question “New input completed – calculate now?” and the program will automatically calculate the finished shape and display it on the screen. IF YOUR COMBINATION OF FORMS DOES NOT PRODUCE A CLOSED CRYSTAL, a pop-up window will appear saying “Closed form not defined”. If you get this message, press “Cancel” and “Add” more forms.

Manipulating the image

- Once you have an image, you can work with it in various ways.
- You can choose a “Cursor Mode” to “Identify Faces” (click on a face), to “Resize Forms” (left-click on a face to make it grow – the central distance is increased, right-click to make it shrink – the central distance is decreased), or to “Rotate” the crystal (click and drag).
- You can “Resize” the crystal by clicking on the Resize buttons.
- You can “Set Center” to a new location.
- You can view the crystal in 3D mode, perhaps making stereo pairs for 3D viewing, or clicking on the “Symmetry (3D) button to view the symmetry elements present.

Printing:

To print an image of a crystal, use the "Print " option in the FILE menu. There are quite a few options in the “Print Graphics Image” dialog box that you should consider.

Other things you can do:

A variety of other options are available. You can experiment. A pdf version of the manual is in the Shape 7 folder.

SEVERAL WAYS OF DESCRIBING THE 32 CRYSTAL CLASSES

Rogers (1937)	Schoenflies	Full Hermann-Mauguin	SHAPE	(Example)
TRICLINIC				
Pedial	C ₁	1	1	calcium thiosulfate
Pinacoidal	C _i	-1	B1	albite
MONOCLINIC				
Sphenoidal	C ₂	2	2	clinochredite
Domatic	C _s	m	m	tartaric acid
Prismatic	C _{2h}	2/m	2/m	gypsum
ORTHORHOMBIC				
Rhombic-pyramidal	C _{2v}	m m 2	mm2	hemimorphite
Rhombic-disphenoidal	D ₂	2 2 2	222	epsomite
Rhombic-dipyramidal	D _{2h}	2/m 2/m 2/m	mmm	barite
TRIGONAL				
Trigonal-pyramidal	C ₃	3	3	sodium periodite
Rhombohedral	C _{3i}	-3	B3	phenacite
Trigonal-trapezohedral	D ₃	3 2	32	low quartz
Ditrigonal-pyramidal	C _{3v}	3m	3m	tourmaline
Hexagonal-scalenohedral	D _{3d}	-3 2/m	B3m	calcite
TETRAGONAL				
Tetragonal-pyramidal	C ₄	4	4	wulfenite
Tetragonal-disphenoidal	S ₄	-4	B4	-----
Tetragonal-dipyramidal	C _{4h}	4/m	4/m	scheelite
Tetragonal-trapezohedral	D ₄	4 2 2	422	nickel sulfate
Ditetragonal-pyramidal	C _{4v}	4 m m	4mm	iodosuccinimide
Tetragonal-scalenohedral	D _{2d}	-42m	B42m	chalcopyrite
Ditetragonal-dipyramidal	D _{4h}	4/m 2/m 2/m	4/mmm	zircon
HEXAGONAL				
Hexagonal-pyramidal	C ₆	6	6	nepheline
Trigonal-dipyramidal	C _{3h}	-6	B6	disilverorthophosphate
Hexagonal-dipyramidal	C _{6h}	6/m	6/m	apatite
Hexagonal-trapezohedral	D ₆	6 2 2	622	high quartz
Dihexagonal-pyramidal	C _{6v}	6 m m	6mm	zincite
Ditrigonal-dipyramidal	D _{3h}	-6 m 2	B6m2	benitoite
Dihexagonal-dipyramidal	D _{6h}	6/m 2/m 2/m	6/mmm	beryl
ISOMETRIC				
Tetartoidal	T	2 3	23	ullmanite
Diploidal	T _h	2/m -3	mB3	pyrite
Hextetrahedral	T _d	-4 3 m	B43m	tetrahedrite
Gyroidal	O	4 3 2	432	cuprite
Hexoctahedral	O _h	4/m -3 2/m	m3m	galena

Notes:

1. In the SHAPE program, a B preceding a number indicates an rotary inversion axis. Thus B3 is equivalent to -3. SHAPE usage is in column 4, and is a variant of the short Hermann-Mauguin symbols.
2. This list is modified from Dana's System of Mineralogy, Edition 7, volume 1 page 8. A listing of more alternative descriptions can be found in Dana's Textbook of Mineralogy, Fourth Edition (1932) pages 16-18.
3. "Type minerals" or chemicals for most classes are given in column 5, as listed in Dana's Textbook. Ironically, some of them are no longer considered to belong to the class for which they are the supposed type minerals.