

OLYMPUS®

Your Vision, Our Future

Research System Microscope

BX51/BX61

BX2 Series

UIS2
World-leading optics

*Everything
for digital imaging*



Photos courtesy of:
Junko Kyozuka, Associate Professor, Graduate School of Agricultural and Life Sciences, The Tokyo University (P.11 below)
Prof. Nakatani, Biochemistry course, School of medicine, Showa University (P.13 above)
Prof. Tadokoro, Pathology class, School of medicine, St. Marianna University (P.15)



ECO-PRODUCTS

BX51/BX61 are the environmental conscious products according to OLYMPUS's own standards.

Main features of OLYMPUS Eco-products are as follows.

- Lead-free and arsenic-free Eco-glass for optics, such as lenses and prisms.
- Exclusion of hexavalent chrome, mercury, lead and cadmium from metal materials and surface treatment of metal.
- Exclusion of lead solders.
- Adoption of cardboard for packing materials without styrene foam for promoting the recycling.

* A definition of exclusion depends on OLYMPUS standard. Some accessories are inapplicable.

Please visit our web site for further information: <http://www.olympus.co.jp/en/eco-products/>

- OLYMPUS CORPORATION has obtained the ISO9001/ISO14001.
- OLYMPUS CORPORATION has obtained the MD540624/ISO13485.
- Illumination devices for microscope have suggested lifetimes. Periodic inspections are required. Please visit our web site for details.
- Windows is a registered trademark of Microsoft Corporation in the United States and other countries. All other company and product names are registered trademarks and/or trademarks of their respective owners.
- Images on the PC monitors are simulated.
- Specifications and appearances are subject to change without any notice or obligation on the part of the manufacturer.

OLYMPUS®

OLYMPUS CORPORATION
Shinjuku Monolith, 3-1, Nishi Shinjuku 2-chome, Shinjuku-ku, Tokyo, Japan
OLYMPUS LIFE SCIENCE EUROPA GMBH
Postfach 10 49 08, 20034, Hamburg, Germany
OLYMPUS AMERICA INC.
3500 Corporate Parkway, Center Valley, Pennsylvania 18034-0610, U.S.A.
OLYMPUS SINGAPORE PTE LTD.
491B River Valley Road, #12-01/04 Valley Point Office Tower, Singapore 248373

OLYMPUS AUSTRALIA PTY. LTD.
31 Gilby Road, Mt. Waverley, VIC 3149, Melbourne, Australia.
OLYMPUS LATIN AMERICA, INC.
5301 Blue Lagoon Drive, Suite 290 Miami, FL 33126, U.S.A.
OLYMPUS (CHINA) CO., LTD.
A8F, Ping An International Financial Center, No. 1-3, Xinyuan South Road,
Chaoyang District, Beijing, China, 100027

www.olympus.com

Printed in Japan M1540E-0909B

The UIS2 optical system: a new evolutionary advance in fluorescence digital imaging.

The new BX2 series addresses the research demands of the future with Olympus' most advanced optical system to date. UIS2 optics deliver the world's highest standard of fluorescence performance, along with the image quality and clarity needed for progress of fast-developing life science research programs. With increased S/N ratio, high optical transmission, and diverse illumination capabilities, the UIS2 optical system provides excellent performance over a newly extended wavelength range between UV and IR. This improvement meets all current demands in fluorescence digital imaging and provides a firm foundation for future developments. As modern research advances to ever higher levels of complexity and sophistication, the need for quality and dependability makes the BX2 series today's most convincing solution.

UIS2

World-leading optics



BX51
System Microscope



BX61
Motorized System Microscope

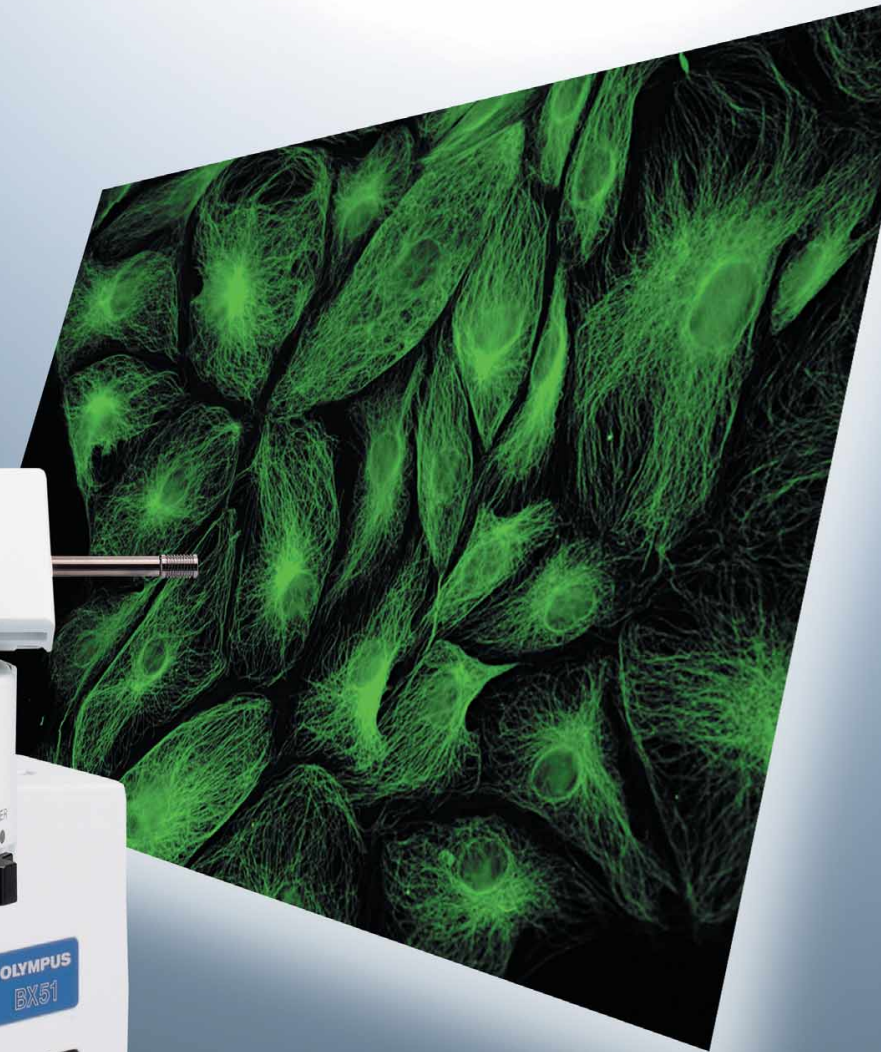

Higher S/N ratio enables clear capture of weak fluorescence emissions.

World leading fluorescence performance — a vital key to modern life science research

The ideal in fluorescence observation is to capture high-contrast images with the lowest exposure to excitation light, thus minimizing the chances of cell damage and fluorescence fading. With increased S/N ratio, high transmission of the objectives and the high performance mirror unit, Olympus' UIS2 optics provide excellent performance in fluorescence by obtaining bright images from weak fluorescence signals.

Improved performance of interference type fluorescence mirror units

The new fluorescence mirror units achieve high S/N ratio by application of new coating technology to the filters and optimal design of excitation and emission filters' characteristic. The hard coating, which prolongs the lifetime of filter, is applied to all Olympus fluorescence mirror units.

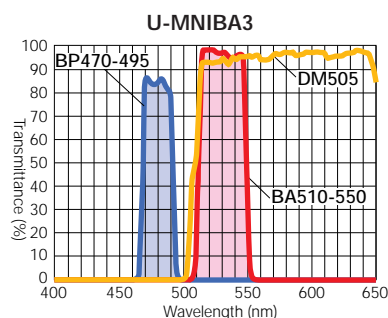

High-quality fluorescence mirror units for fluorescence proteins

The HQ type mirror units are ideal for the wavelength characteristics of ECFP/EGFP/EYFP/DsRed. With sharp upstroke and high transmission, the mirror unit efficiently transmits the fluorescence emitted from fluorescence proteins. This allows bright observation images even with weak excitation light, while preventing fluorescence fading and minimizing the chances of cell damage.

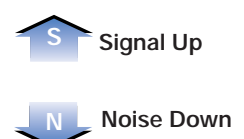
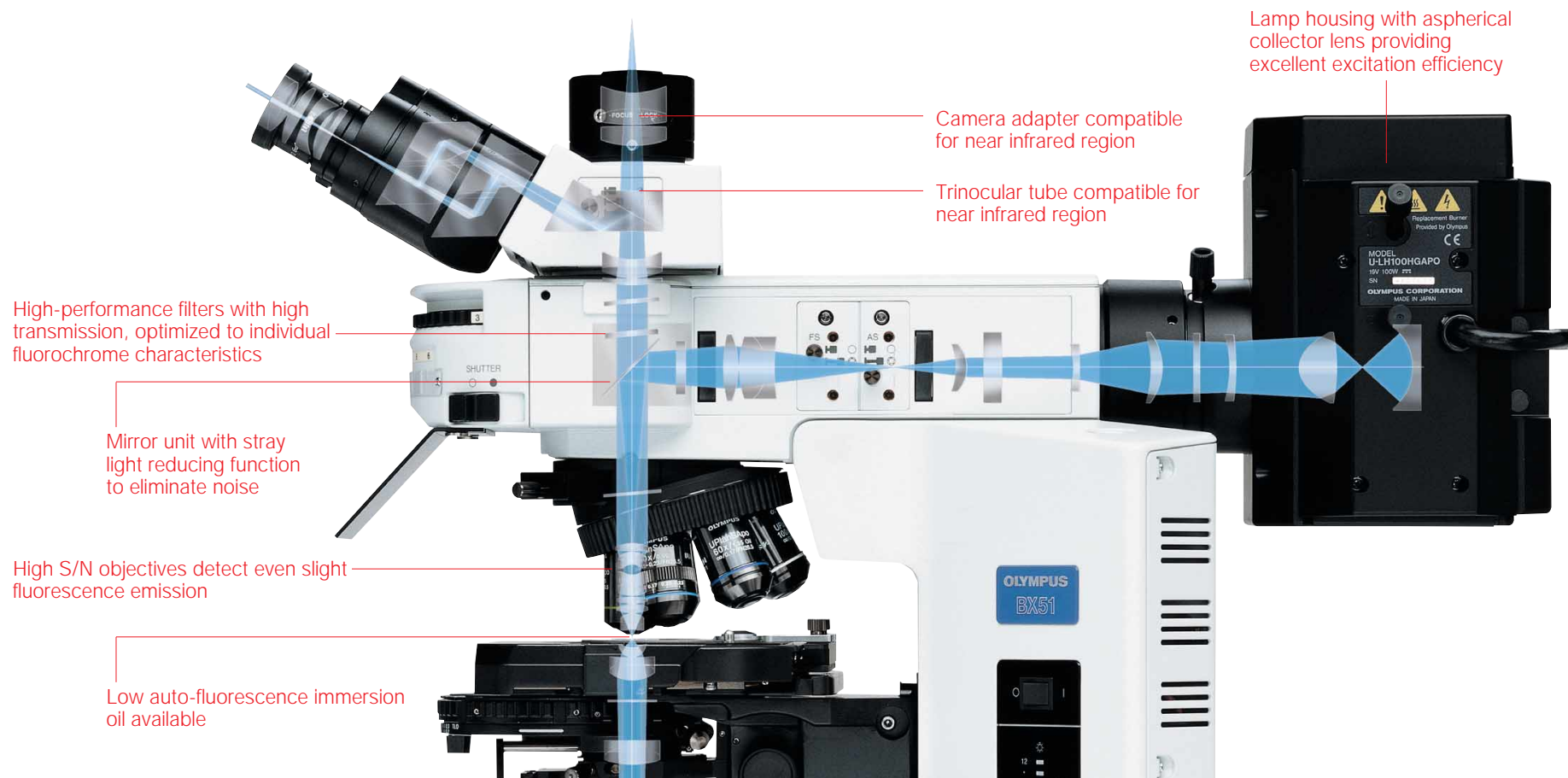
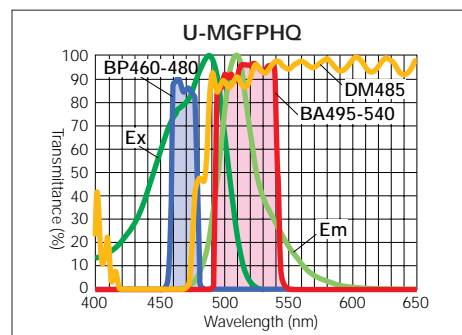

Excellent trinocular tube performance even in the near infrared region

The trinocular tube U-TR30NIR improves the transmission and compensates for aberrations over a wider wavelength range. A new multi-coatings is applied to the trinocular optical surfaces to widen the IR spectral characteristics and allow for observation of newly developed fluorochromes in the near-infrared region.

Camera adapter suitable for near infrared region

Users can choose from a variety of low magnification camera adapters with C-mount, all IR compatible.



① U-TV0.35x-C-2 ② U-TV0.5x-C-3 ③ U-TV0.63x-C ④ U-TV1x-2+U-CMAD3

High transmission across a wide wavelength spectrum

The latest UIS2 objectives achieve a flat, high transmission over a wide wavelength spectrum, from visible to near infrared — thanks to the incorporation of a newly-developed ultra-wide wavelength reflection prevention coating (UW multi-coatings). The improvement in transmission in the near infrared region is especially notable, and typifies the high performance which makes UIS2 objectives the natural choice in many leading-edge research fields.

Stray light reducing function

Olympus mirror units are equipped with a unique function to eliminate the stray light that could increase the background noise in fluorescence image.

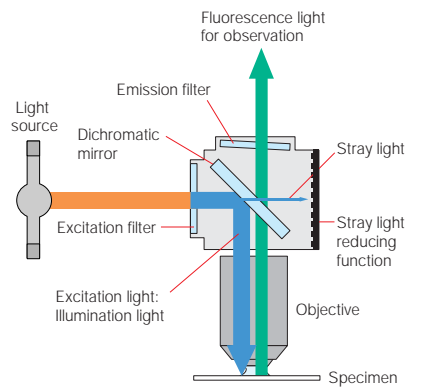

The best S/N ratio...and the best fluorescence performance

Olympus UIS2 objectives provide the best S/N ratio by employment of totally new design to curtail autofluorescence from all possible sources — glass material, coating and cementing material. UIS2 objectives achieve high N.A. while reducing autofluorescence, two benefits previously considered incompatible. With these improvements, UIS2 objectives provide the best fluorescence image.

Low auto-fluorescence immersion oil

The ability to reduce auto-fluorescence normally associated with immersion oil makes this product well suited for fluorescence microscopy. Resistance to crystallization allows it to be used over long periods of time.

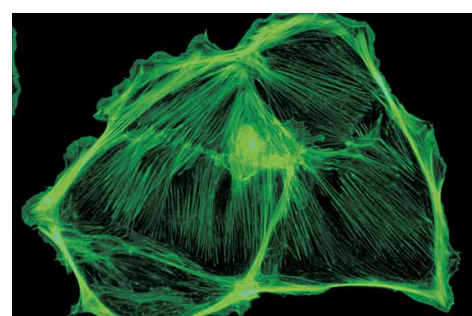

Image captured by the UIS2 objective

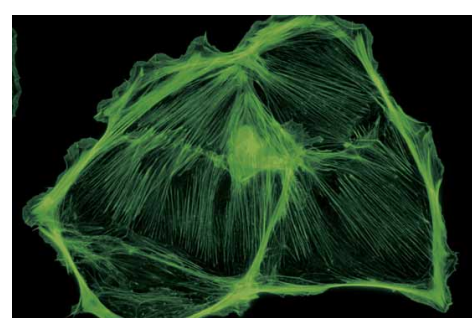

Image captured by a conventional objective

High N.A. objectives for fluorescence imaging

The BX2 series features the newly-developed PLAPON60XO objective, offering for the world's highest N.A. (1.42) for fluorescence imaging, and the UPLSAPO100XO with high 1.4 N.A. and advanced universal features. In addition to their outstanding fluorescence S/N ratio, they enjoy UV transmission. The UPLSAPO100XO objective is especially notable for maintaining its transmission down to the 340 nm wavelength.



Up to near infrared compensation for chromatic aberration

The Super Apochromat performance of UPLSAPO series objectives compensates for all chromatic aberrations, from visible to up to 1000nm wavelength light. Clear images without color shift are provided even in multi-color observations. Imaging all the way from UV to IR can be performed with a single objective.

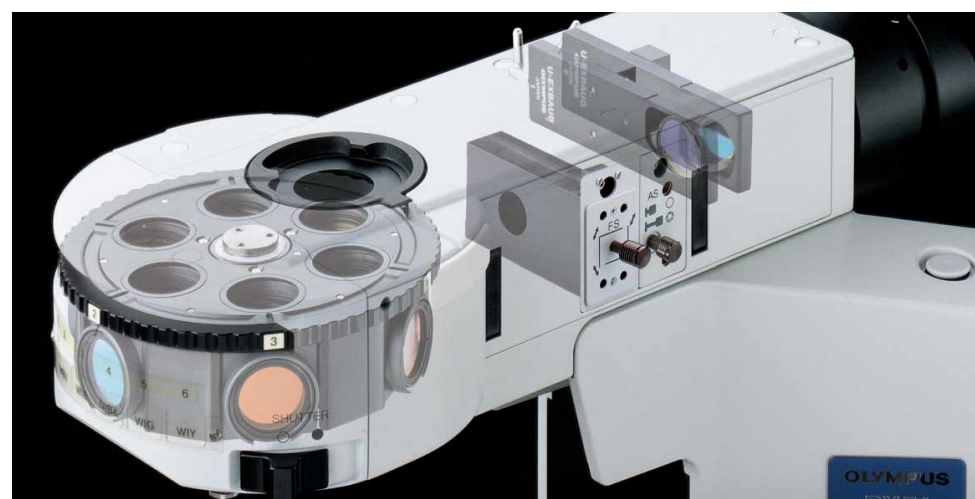
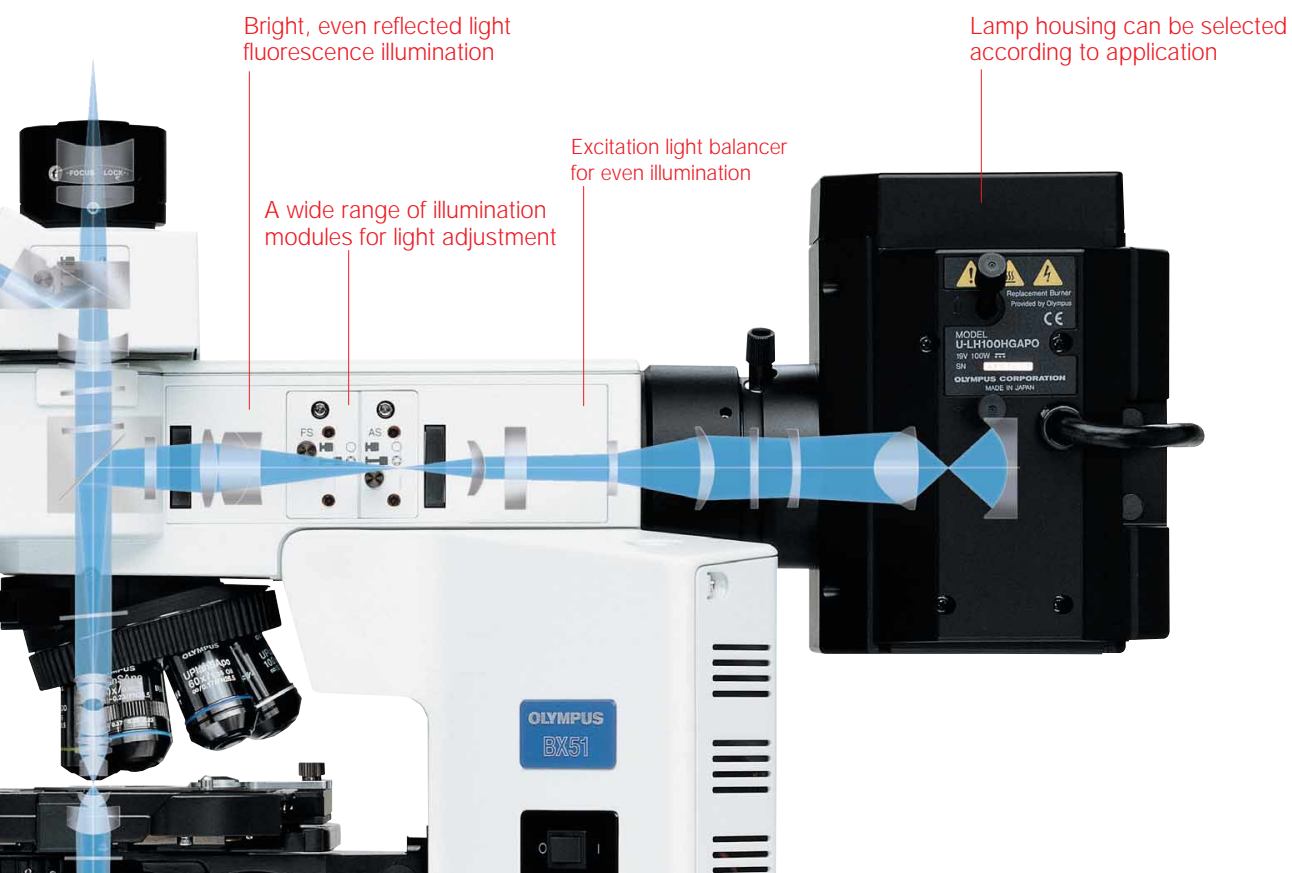

Fluorescence excitation balancers/ U-EXBABG, U-EXBAUB, U-EXBAUG
 When observing double and triple stained specimens, both observation and photography can be conducted by arranging or altering the fluorescence brightness while freely changing the excitation light for each stained color. An excitation balancer is attached in the parallel light path, so there is no unevenness in the visual field.



Pinhole field stop module/BX-RFSPOT
 This slider makes it possible to use the light source as a spotlight, illuminating tiny individual areas on the fluorescence specimen — an especially valuable feature in experimental work. The slider is attached to the BX-RFA fluorescence illuminator in the field stop position.



Rectangular field stop for digital imaging/U-RFSS
 The rectangular field stop can be set to the exact size of the imaging sensor to avoid fading outside of the imaging area and damaging sensitive tissue.



Unnecessary exposure area caused by a round field stop

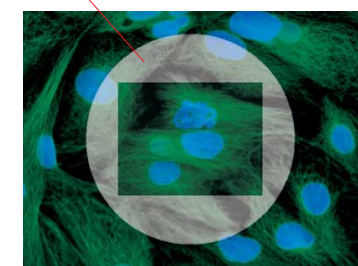
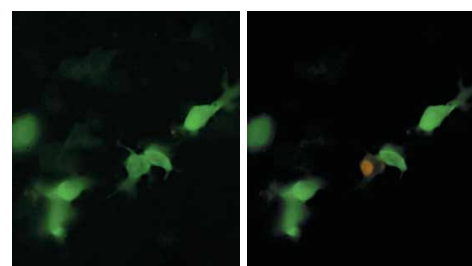
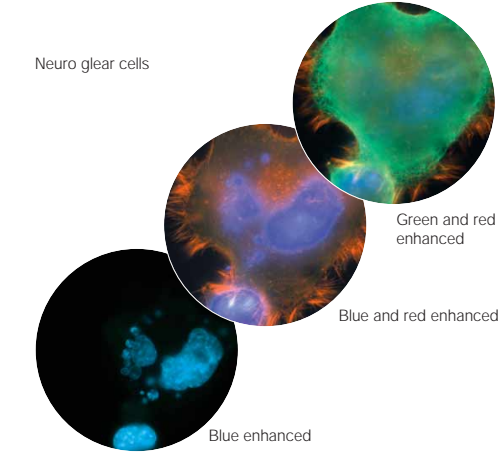

High-rigidity reflected light illuminator
 Two types of reflected light illuminator are provided: the multi-purpose BX-RFA, suitable for a wide range of different research projects, and the economical BX-URA2. Up to 6 mirror units can be attached in the cassette, which is especially useful when observing multi-stained specimens. A click weight adjustment function is provided for filter exchange, and a click release function that eliminates vibration.



Lamphouses according to application
 Two 100 W mercury lamphouses (U-LH100HG and U-LH100HGAP0) are available, the latter with color correction extending to UV wavelengths. The U-LH75XEAP0 is available for 75 W xenon lamps, also with correction extending to the UV.



Double lamp housing adapter U-DULHA for exchange between two light sources
 When two different light sources are attached at the same time, this adapter unit enables easy exchange between them according to the user's application. (Optical path: 100/0, 0/100, F.N.11)



Luminous mirror unit indicator for easy confirmation in dark room
 Bright, easy-to-see self-illuminated labels are used to denote fluorescence filter sets, easily visible in a dark room. Three filter positions are displayed simultaneously making the next selection of the next filter easy and intuitive.



Bright, consistent illumination
 Twice the brightness provided by conventional models can be obtained with the 10X ~ 20X objectives, or 2-3 times the brightness when light is narrowed to F.N. 12. This enables efficient observations at lower magnifications.

Convenient 6-position filter sliders U-RSL6/U-RSL6EM
 Setting the excitation and emission filters on this sextuple filter slider enables synchronous and continuous exchange between positions. With ND filters attached, illumination can be adjusted in 6 steps.



Confocal laser scanning biological microscope/FV1000
 The FluoView/FV1000 is a next-generation imaging system designed for high-resolution, confocal observation of both fixed and live cells. The FV1000 offers advances in confocal system performance while providing the speed and sensitivity required for live cell imaging with minimal risk of damage to specimens. In addition, the FV1000 offers a revolutionary synchronized laser scanning system called the SIM Scanner. While one laser stimulates, the second laser simultaneously provides high-resolution imaging. This coordination of laser stimulation and imaging makes the FV1000 an ideal choice for FRAP, FLIP and photoactivation.

*FV1000 is a class 3B laser product.



Varied illumination and advanced optics deliver top quality digital images.

Excellent color reproduction from daylight illumination

Since Olympus microscopes can apply ideal color temperature at natural daylight (5500 K) throughout the light source, the objectives and the CCD camera, the camera captures color information accurately and provides faithful reproduction on the display.

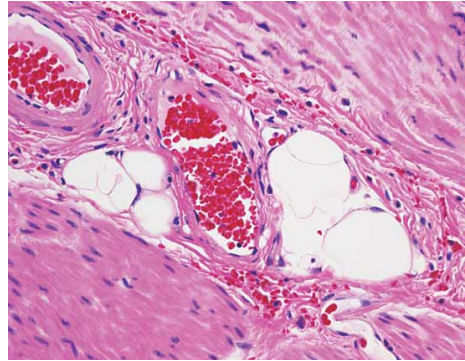

UIS2 optics provide high transmission for clear, flat images

In the UIS2 optical system, improved transmission and compensation for chromatic aberration over a wide wavelength spectrum are not only characteristics of the objectives, but also of image forming components such as the trinocular tube and video camera adapter. As a result, images at all magnification levels are flat, sharp, clear and free from color shift.

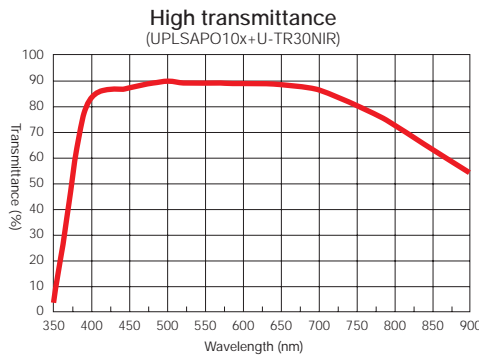

Optimal trinocular tube for digital imaging

In digital imaging, the best light intensity balance between the observation side and the digital camera side should be equal. Olympus' new trinocular tube U-TR30NIR provides a choice of three light path exchange: 100% for binocular, 100% for camera, or 50% each for binocular and camera.

Digital camera/ DP72

High-resolution digital images equivalent to 12.8 million pixels* captured in approx. 2.5 seconds — from brightfield to fluorescence.

Thanks to its high-speed hardware, the DP72 can capture high-resolution images equivalent to 12.8 million pixels in around 2.5 seconds*. The camera's high sensitivity and low noise (equivalent to the level of ISO 1600) ensure clear fluorescence imaging, while the resolution quality allows precise representation of particular specimen areas.

By shifting the pixels of the 1.45 million pixel 2/3 inch CCD (one pixel = 6.45 μm), it is possible to record still images equivalent to the maximum image recording size (4140 x 3096) or effective image size of 12.5 million pixels.



Digital camera/ DP25

5 megapixel high-precision, high-quality technology for microscopic imaging

In addition to live display at a high frame rate of 8 fps with exceptional quality (2560 x 1920 pixels), the DP25 is equipped with a color profile that provides full-color images in real-time, allowing faithful color reproduction of specimens. It can easily be connected with just 1 cable (6 pin) to a PC with a FireWire (IEEE1394) port. And it can be connected to a laptop PC as well via a FireWire (IEEE1394a) PC card.

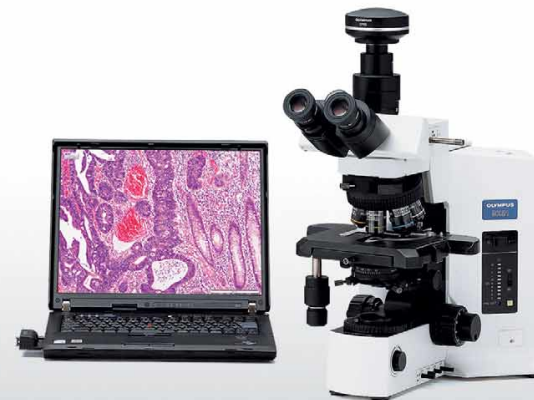

Digital camera/ DP20

Providing live image display speed that's close to real-time while maintaining high-precision image quality

The DP20 can display high-precision images of 2 megapixels in UXGA (1600 x 1200) format at 15 frames/second. Additionally, it provides faithful 8-bit RGB color reproduction that is ideal for conferences both large and small. The handset control unit has functional key layout for quick and easy control.

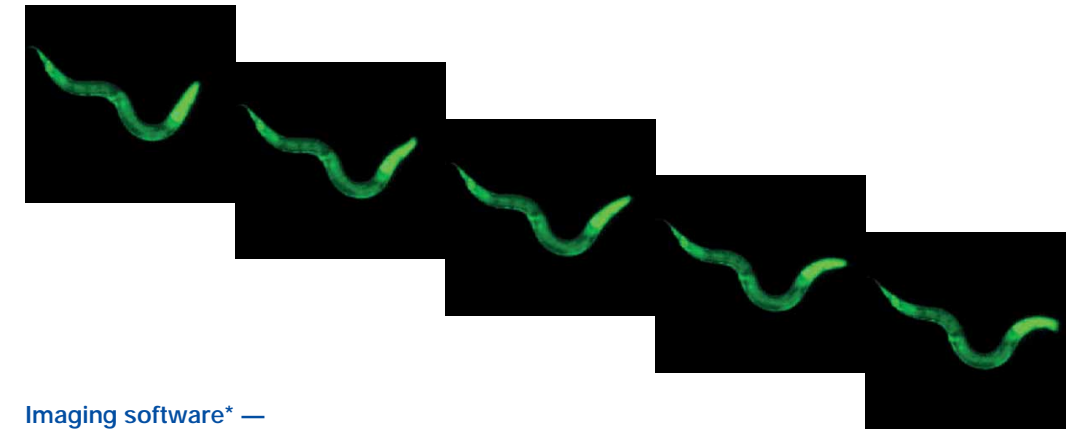

Imaging software* — Software to support basic functions

DP2-BSW is a simple and easy-to-use, thus user-friendly image capturing software package. It can be used to control different types of motorized units, and to perform both still time-lapse images and live image movie recording.

*As per the software for Europe, please contact the nearest Olympus representative office.

- Intuitive, easy-to-use GUI (Graphical User Interface). Tool bar items can be user-customized and menu icons restricted to frequently used functions.

- A reference scale bar can be displayed, overlaid, and subsequently burned onto a saved image. Arrows and text can also be entered and saved in an image.

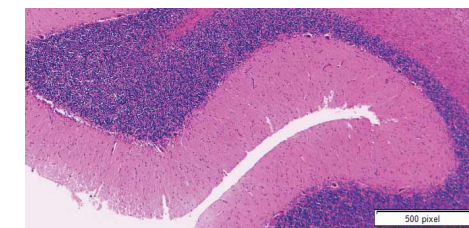

- A focusing indicator function makes focusing in a live image easy; a line profile function lets you focus accurately on user-defined regions. Additionally, the region in focus can be magnified up to 16 times.

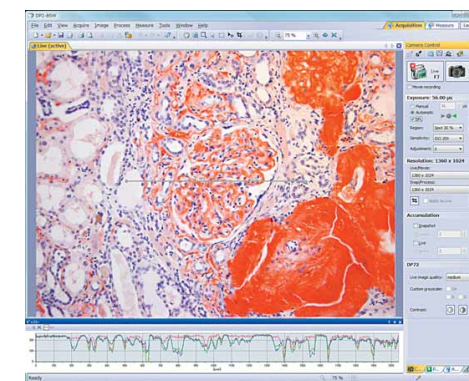

- Time-lapse feature lets you set the starting time of a photo sequence, the duration, the number of images, and thus the chronological development of the whole sequence.

- Combine multiple color images (from a single specimen) from different excitation wavelengths, into a single final image (grayscale or color).

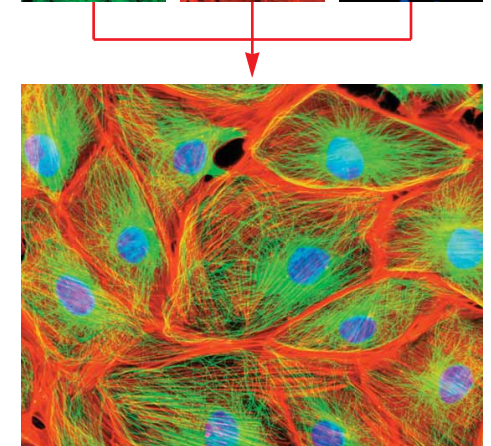
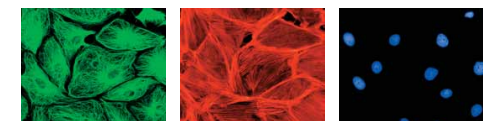

- BX61 motorized microscopes can be controlled from a personal computer. Different conditions can be set for respective observation methods, and the observation method can be changed by simply clicking on a button on the controller screen.

- Several functions for measuring live or still images, including point measurements, arbitrary line, polygon, circle and ellipse or rectangle measurements, are integrated. For further processing the measurements can be exported to MS Excel with the simple click of a mouse.

The advanced UIS2 system delivers high performance over a wider wavelength spectrum.

UIS2 optics inherit high expandability

As heir to Olympus' infinity-corrected optical system, in which the tube lens is built into the observation tube, UIS2 optics display no image deterioration even when many different optical components or equipment are inserted in the parallel light path. This inherent expandability gives users ample freedom to construct the system in a way that meets their specific requirements.

UW (Ultra wideband) multi-coatings reduces autofluorescence and improves S/N ratio

By using carefully selected raw materials for glass, and applying advanced UW multi-coatings technology, Olympus has reduced objective autofluorescence and significantly improved the S/N ratio.

Flat, high transmission over wide wavelength range from UV to IR

UW multi-coatings also yields a flat, high transmission over a wide wavelength range, ensuring high performance in research tasks using different types of fluorochromes.

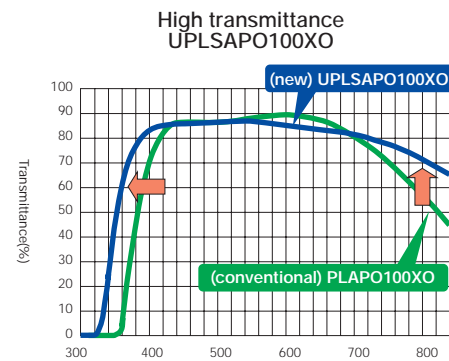

Complete chromatic aberration compensation up to near infrared region

UPLSAPO objectives completely eliminate chromatic aberration up to the near infrared region, matching the ability of Super Apochromat objectives to provide clear images without overlapping colors or color shift. As a result, a single objective can perform imaging from UV to IR wavelengths.

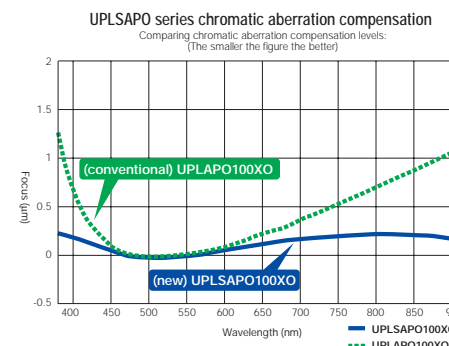

■ UPLSAPO series

Thanks to the application of Olympus' original UW multi-coatings, these Super Apochromat objectives fully compensate for both spherical and chromatic aberrations from the UV to the near infrared region. Their sensitivity to fluorescence emissions ensures the acquisition of sharp, clear images, without color shift, even in brightfield and Nomarski DIC observations. For quality and performance, they offer an unbeatable solution to every kind of digital imaging need.

■ PLAPON series

Designed for unsurpassed resolution and contrast, these Plan Apochromat objectives keep chromatic aberration down to an absolute minimum. The PLAPON60XO, to which the UW multi-coatings is applied, is the first in the world to achieve N.A. 1.42 for fluorescence imaging.



UIS2 objectives

Objective	N.A.	W.D. (mm)	F.N.	Cover glass thickness (mm)	Immer-sion	Spring	Cor-rec-tion ring	Iris dia-phragm	Water proof and oil proof function
UPLSAPO 4X	0.16	13	26.5	—					
UPLSAPO 10X2	0.4	3.1	26.5	0.17					
UPLSAPO 20X	0.75	0.6	26.5	0.17		○			
UPLSAPO 20XO	0.85	0.2	26.5	—	Oil	○			
UPLSAPO 40X2	0.95	0.18	26.5	0.11-0.23		○	○		
UPLSAPO 60XW	1.20	0.28	26.5	0.15-0.21	Water	○	○		○
UPLSAPO 60XO	1.35	0.15	26.5	0.17	Oil	○			○
UPLSAPO 100XO	1.40	0.13	26.5	0.17	Oil	○			○
PLAPON 1.25X	0.04	5	26.5	—					
PLAPON 2X	0.08	6.2	26.5	—					
PLAPON 60XO	1.42	0.15	26.5	0.17	Oil	○			○
UPLFLN 4X	0.13	17	26.5	—					
UPLFLN 10X2	0.3	10	26.5	—					
UPLFLN 20X	0.5	2.1	26.5	0.17		○			
UPLFLN 40X	0.75	0.51	26.5	0.17		○			
UPLFLN 40XO	1.3	0.2	26.5	0.17	Oil	○			○
UPLFLN 60X	0.9	0.2	26.5	0.11-0.23		○	○		
UPLFLN 60XOI	1.25-0.65	0.12	26.5	0.17	Oil	○		○	○
UPLFLN 100XO2	1.3	0.2	26.5	0.17	Oil	○			○
UPLFLN 100XO12	1.3-0.6	0.2	26.5	0.17	Oil	○		○	○
UPLFLN 10X2PH	0.3	10	26.5	—					
UPLFLN 20XPH	0.5	2.1	26.5	0.17		○			
UPLFLN 40XPH	0.75	0.51	26.5	0.17		○			
UPLFLN 60XOPH	1.25-0.65	0.12	26.5	0.17	Oil	○		○	○
UPLFLN 100XO2PH	1.3	0.2	26.5	0.17	Oil	○			○
UPLFLN 4XP	0.13	17	26.5	—					
UPLFLN 10XP	0.3	10	26.5	—					
UPLFLN 20XP	0.5	2.1	26.5	0.17		○			
UPLFLN 40XP	0.75	0.51	26.5	0.17		○			
UPLFLN 100XOP	1.3	0.2	26.5	0.17	Oil	○			○

Objective	N.A.	W.D. (mm)	F.N.	Cover glass thickness (mm)	Immer-sion	Spring	Cor-rec-tion ring	Iris dia-phragm	Water proof and oil proof function
PLN 2X	0.06	5.8	22	—					
PLN 4X	0.1	18.5	22	—					
PLN 10X	0.25	10.6	22	—					
PLN 20X	0.4	1.2	22	0.17		○			
PLN 40X	0.65	0.6	22	0.17		○			
PLN 50XOI	0.9-0.5	0.2	22	—	Oil	○		○	○
PLN 100XO	1.25	0.15	22	—	Oil	○			
PLN 10XPH	0.25	10.6	22	—					
PLN 20XPH	0.4	1.2	22	0.17		○			
PLN 40XPH	0.65	0.6	22	0.17		○			
PLN 100XOPH	1.25	0.15	22	—	Oil	○			
PLN 4XP	0.1	18.5	22	—					
ACHN 10XP	0.25	6	22	—					
ACHN 20XP	0.4	3	22	0.17					
ACHN 40XP	0.65	0.45	22	0.17		○			
ACHN 100XOP	1.25	0.13	22	—	Oil	○			
MPLAPON 100XO	1.4	0.1	26.5	0	Oil	○			○
MPLFLN 40X	0.75	0.63	26.5	0		○			
APON 60XOTIRF	1.49	0.1	22	0.13-0.19	Oil		○		○
UAPON 100XOTIRF	1.49	0.1	22	0.13-0.19	Oil		○		○
UAPON 150XOTIRF	1.45	0.08	22	0.13-0.19	Oil		○		○

All UIS2 objectives and WHN eyepieces: lead-free eco-glass

UIS objectives

Objective	N.A.	W.D. (mm)	F.N.	Cover glass thickness (mm)	Immer-sion	Spring	Cor-rec-tion ring	Iris dia-phragm	Oil proof cap
PLFL 100X	0.95	0.2	26.5	0.14-0.2		○	○		

■ UPLFLN (UPLFLN-PH) series

These plan objectives also provide flat images with high transmission up to the near infrared region of the spectrum through the employment of UW multi-coatings. With their high S/N ratio, excellent resolution and high contrast imaging, they are especially effective in brightfield and Nomarski DIC observations. The UPLFLN-PH series is optimized for phase contrast observation.



■ PLN(PLN-PH) series

Ideal for a range of clinical and research applications, these high quality objectives feature excellent flatness up to F.N. 22 in transmitted brightfield (phase contrast) observation. The PLN-PH series is specifically designed for phase contrast work.



New DIC observation system optimizes the specimen image at wider magnifications.

Nomarski DIC

Clear, high-contrast imaging from low to high magnifications.

Brightfield

Optimum shearing value according to the specimen

Three types of prisms with different shearing value are provided to define contrast and resolution.

New DIC system allows wider selection

More DIC-compatible objectives are available in UIS2, and users can select the most suitable shearing value for a given specimen from among 10X to 100X objectives. In addition, combination with other observation methods and components is simpler and more convenient.

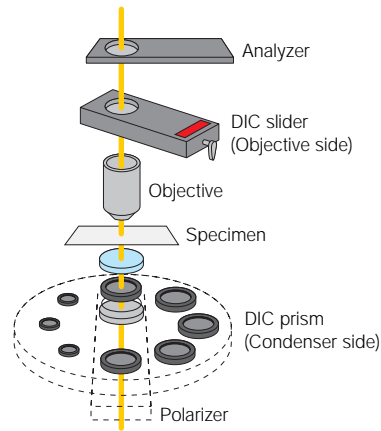

High contrast for thin specimens U-DICTHC

High contrast can be obtained even in high magnification observations of thin specimens, such as culture cells.

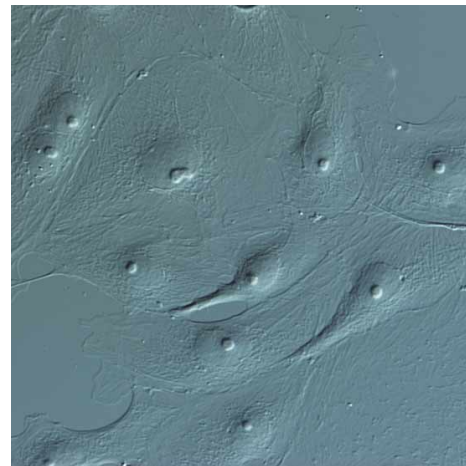

PtK2 cell

High resolution with less glare U-DICTHR

This unit enables observations with high resolution but less glare even for thick specimens used in developmental and genetic research, such as finely-structured diatoms, embryos, zebrafish and *C. elegans*.



C. elegans

Universal condenser/U-UCD8

This condenser, with built-in polarizer, allows simultaneous attachment of up to 8 optical components, freely combined or easily switched.



High all-round performance U-DICT, U-DICTS

Suitable for observing a wide range of general specimens, such as tissue.

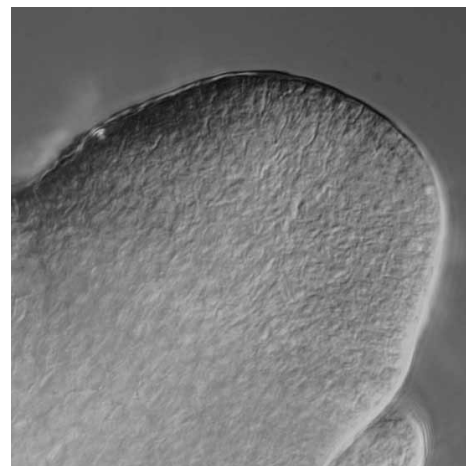

A shoot apical meristem of rice

Septuple revolving nosepiece for DIC/simple POL/U-D7RE

Equipped with a DIC slider slot, the U-D7RE septuple revolving nosepiece allows simultaneous attachment of 7 objectives from low to high magnifications. It is especially suitable for combined DIC and fluorescence observations.



	For high contrast	For high resolution	General	
Specimen	Thin	Thick	—	
DIC slider (objective side)	U-DICTHC	U-DICTHR	U-DICT*1	U-DICTS*1

*1 Choose upon objective magnification

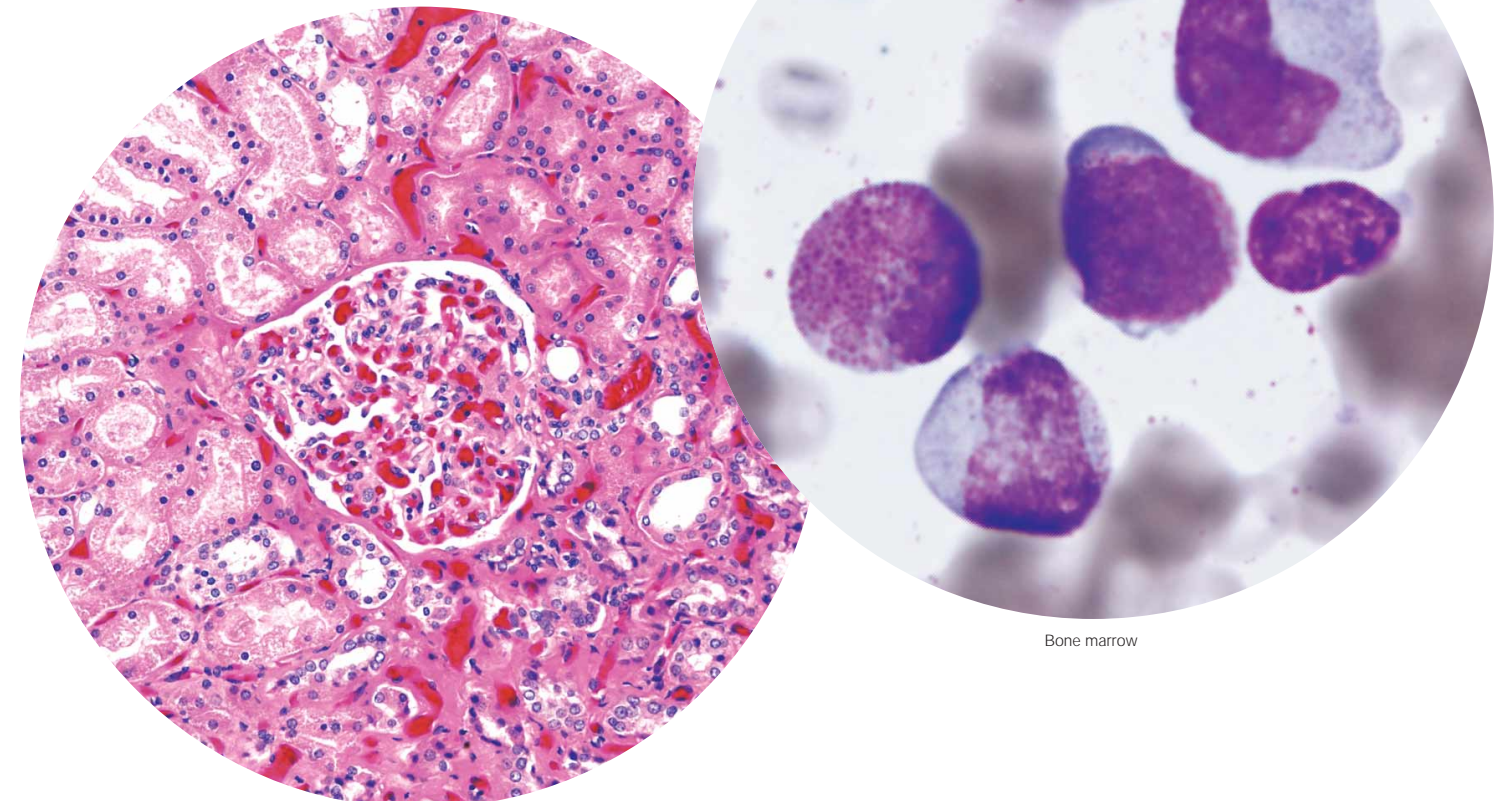

Kidney

Bone marrow

Task-specific brightfield condenser options

According to their purpose, users can choose from the U-SC3, a swing-out condenser suitable for observations from 1.25X-100X; the U-AC2, a highly cost-efficient Abbe-type model; the U-AAC, whose Aplanat-Achromat design comprehensively eliminates chromatic aberration; and the U-ULC-2, a special condenser for ultra low magnifications.

* Select the U-ULC2 condenser for optimal digital imaging with the 1.25X objective.



Clear, high-contrast observation of stained specimens

Image contrast is significantly enhanced by combining UIS2 objectives with the UIS2 eyepiece WHN, which features multi-

coatings on all its surfaces. This makes the image background look whiter, so that the stained area of the specimen stands out more clearly.

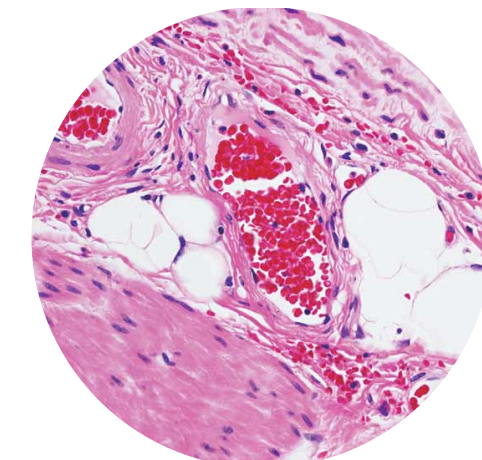

UIS2 image

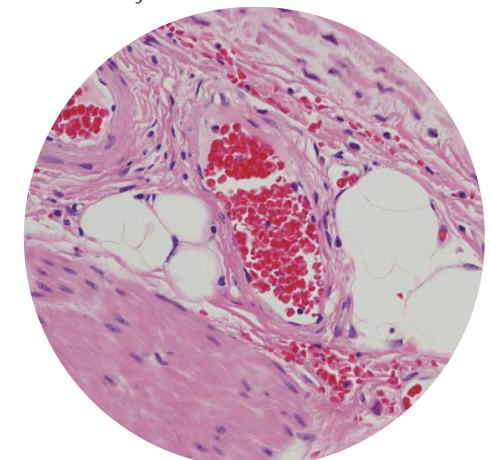

Conventional image

Ideal phase contrast observation with excellent image clarity.

Phase Contrast

High-contrast observation of internal structure of live cells/fungus

• UPLFLN-PH series objectives have high transmission, producing well-balanced images with high contrast even at low magnifications. They are suitable for simultaneous fluorescence, brightfield and darkfield observations.



Phase contrast accessories

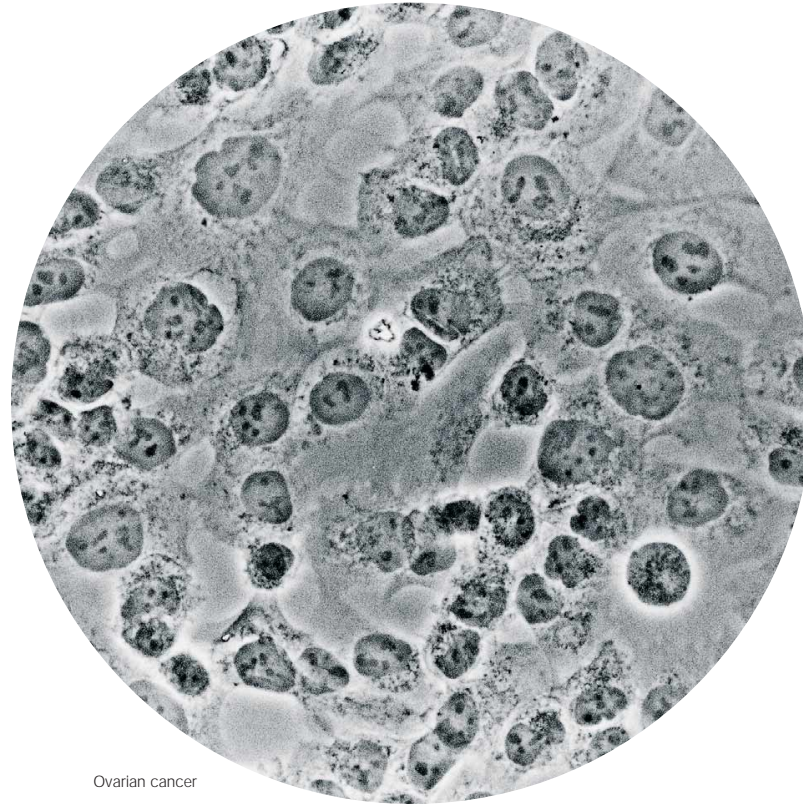

Ovarian cancer

Polarizing observation for wide-area retardation measurement.

Polarizing

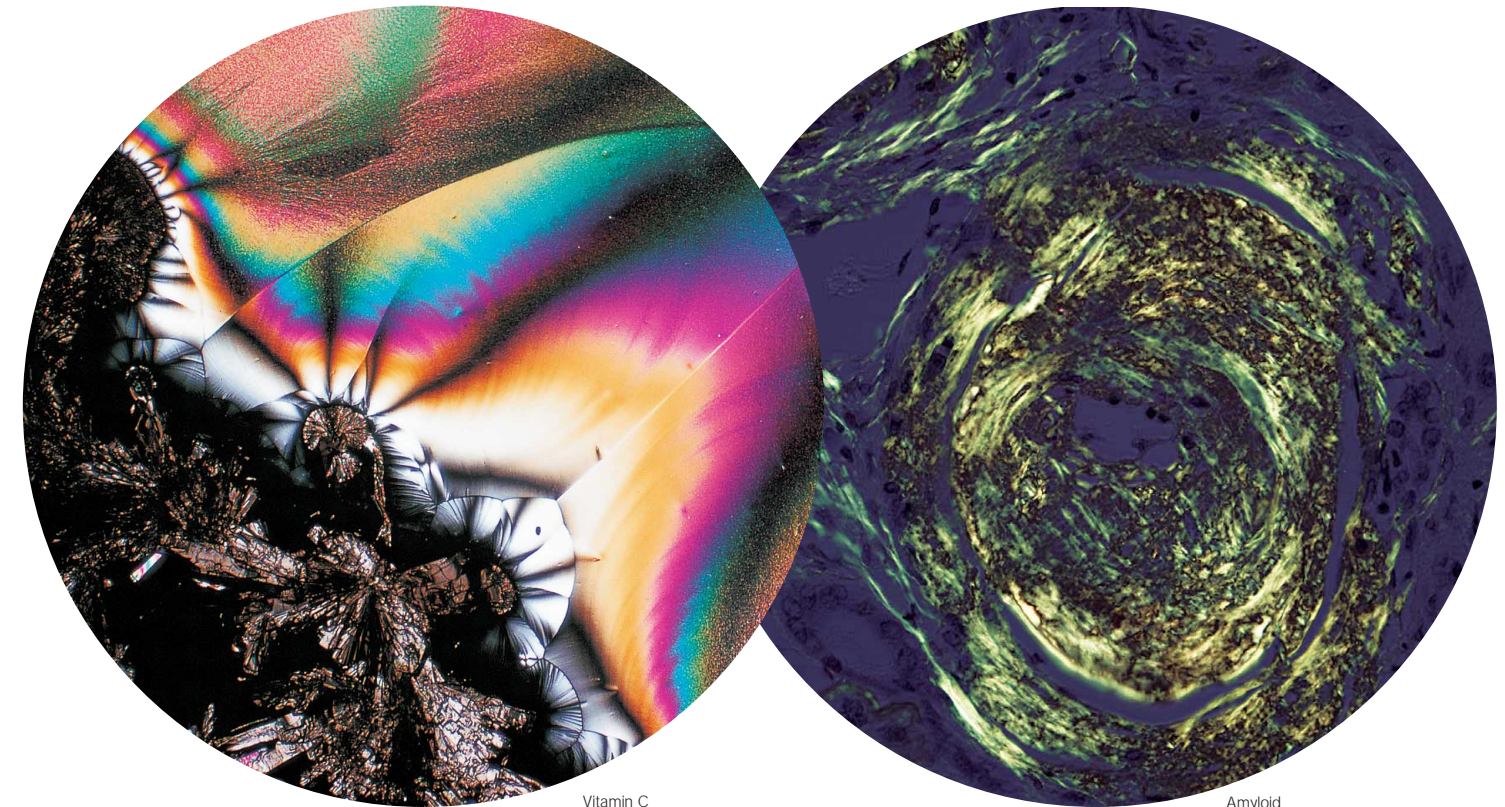

Vitamin C

Amyloid

High-quality darkfield effect at all magnifications.

Darkfield

Observing algae in water, or muscle tissue

Two darkfield condensers are provided: dry darkfield condenser U-DCD, for magnifications from 10X to 100X (up to N.A. 0.80); and oil immersion darkfield condenser U-DCW, for magnifications from 20X to 100X (up to N.A. 1.2).

* Please consult your nearest Olympus dealer for applicable objectives.



U-DCD U-DCW

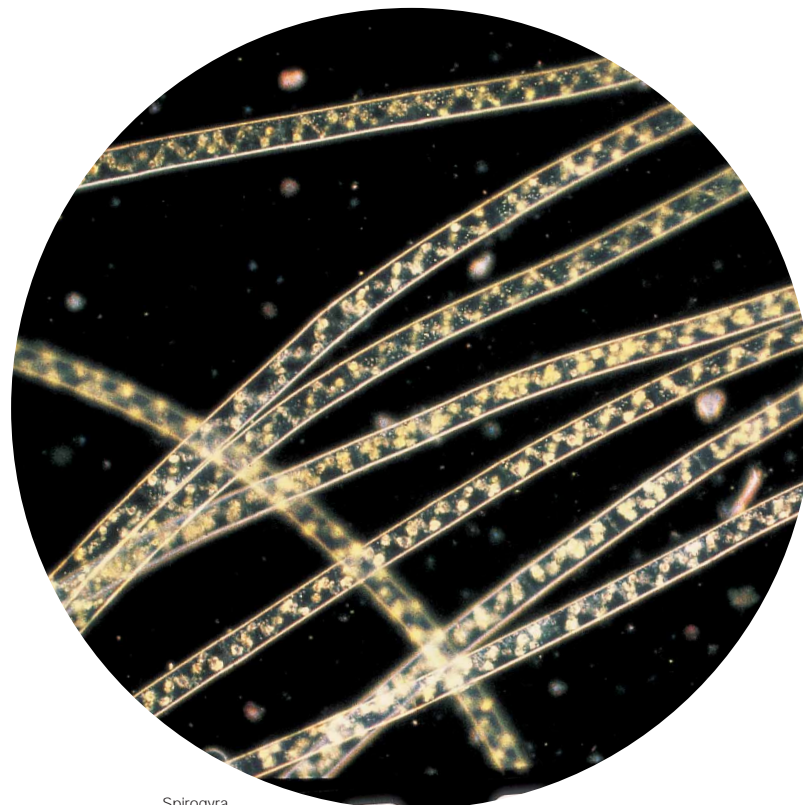

Spirogyra

• With the U-CPA conoscopic observation attachment, the changeover between orthoscopic and conoscopic observation methods is simple and quick — just slide the Bertrand lens control knob in or out.



U-CPA U-POC-2 U-OPA U-P4RE U-AN360P-2



① U-TP530 ② U-TP137 ③ U-TAD ④ U-CBR1 ⑤ U-CBR2 ⑥ U-CWE2 ⑦ U-CSE ⑧ U-CBE ⑨ U-CTB

• UPLFLN-P series objectives, designed for observation under polarizing light, can be used with the revolving nosepiece U-P4RE, which provides a centering function, and the special polarizing light condenser U-POC-2. Also available as an option is the sextuple revolving nosepiece U-P6RE, which allows perfect alignment of the light path among 3 objectives.

• The circular rotatable graduated stage has two centering knobs and allows smooth sample rotation. By setting a click stop every 45 degrees, it enables accurate observation and measurement.

• Mounting an attachable cross-movement mechanical stage (U-FMP) onto the circular rotatable stage makes for improved observation efficiency. Interference between the mechanical stage and the objectives is eliminated, so that images of superb quality can be effortlessly observed at all objective magnification.



U-FMP

Measuring range of compensators

Compensator	Measurement range	Applications
Thick Berek (U-CTB)	0-11,000 nm (20λ)	Measurement of high retardation level (R* > 3λ), (crystals, macromolecules, fiber, etc.)
Berek (U-CBE)	0-1,640 nm (3λ)	Measurement of retardation level (crystals, macromolecules, living organisms, etc.)
Senarmont compensator (U-CSE)	0-546 nm (1λ)	Measurement of retardation level (crystals, living organisms, etc.) Enhancement of image contrast (living organisms, etc.)
Brace-Koehler compensator 1/10λ (U-CBR1)	0-55 nm (1/10λ)	Measurement of low retardation level (living organisms, etc.)
Brace-Koehler compensator 1/30λ (U-CBE2)	0-20 nm (1/30λ)	Enhancement of image contrast (living organisms, etc.)
Quartz wedge (U-CWE2)	500-2,200 nm (4λ)	Approximate measurement of retardation level (crystal, macromolecules, etc.)

*R= retardation level

For more accurate measurement, it is recommended that compensators (except U-CWE2) be used together with the interference filter 45-IF546.

New advances in ergonomics secure improved observation efficiency.

Ergonomics

Rackless stage design

BX2 series microscopes feature a wire-driven stage from which the X-axis guide does not protrude. This design provides a rigid and precise X-Y translation. The X-Y movement weight is freely adjustable. The stage surface has a ceramic coating which provides excellent wear resistance and ensures consistently smooth specimen movement.



Grooved oil stage

For operators who frequently use high magnification oil immersion objectives, Olympus offers a special stage with a groove for oil run-off, to prevent glass slides from sticking to the surface.

Smooth, light rubber knob movement

A rubber cap allowing light and accurate one-finger operation is available as option.



DC power source with no flicker

The microscope body's power source is direct current, which delivers bright observation images without flicker.

Metal construction for maximum rigidity

The microscope bodies are made from aluminum alloy to ensure the high rigidity needed for consistent performance and long-term durability.



Swing-out U-SC3 condenser allows observation over wide area

The swing-out U-SC3 condenser is suitable for all observations from 1.25X to 100X. No special condenser is required for work at ultra low magnifications.



Up to 4 filters can be mounted

Space is provided for an optional fourth filter. This allows any filter to be inserted freely, and the built-in frosted filter to be changed. Changing to direct light observation is a one-touch operation.

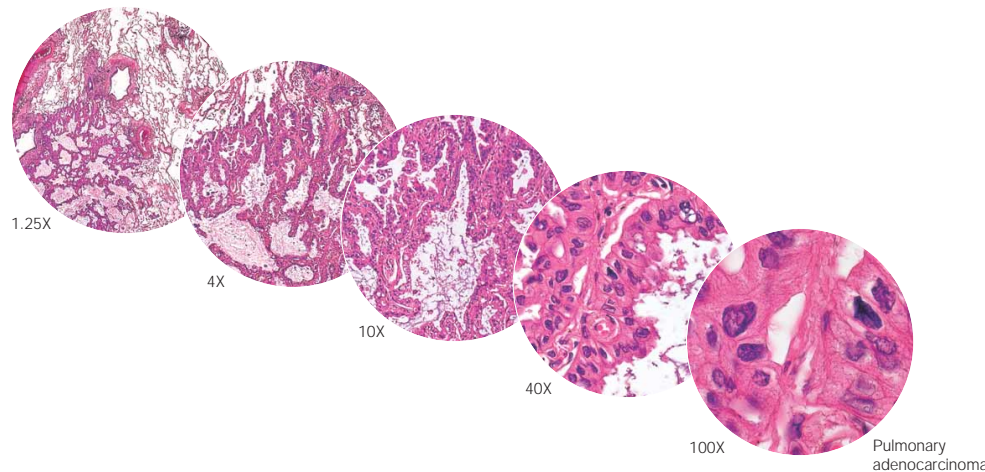

High-efficiency motorized system meets more sophisticated research demands.

Motorized Image Capture Microscope

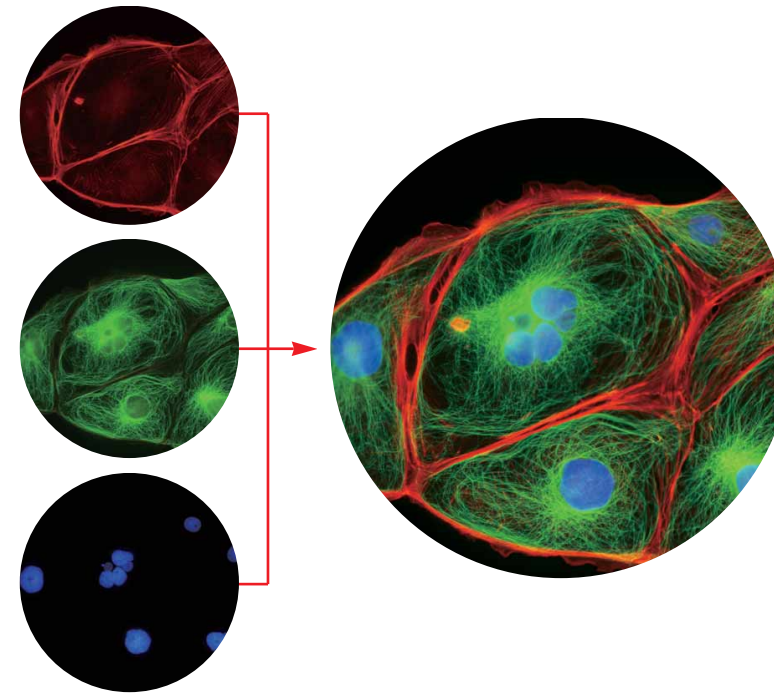

• **Filter wheels / U-FWR, U-FWO and U-FWT**
Motorized exchange of 6 filters. 3 kinds of filters can be attached simultaneously: U-FWR (ø32, 25) for excitation, U-FWO (ø32, 25) for emission and U-FWT (ø32) for transmitted light.



Reflected light illuminator/BX-RFAA

This motorized turret can load up to 6 fluorescence mirror units. Also, equipped with motorized shutter.



Motorized revolving nosepiece/ U-D6REM

Motorized sextuple revolving nosepiece with slider slot for Nomarski DIC.



Motorized universal condenser/ U-UCD8A-2

8 position universal condenser. Different combinations of designated optical components allow for various kinds of transmitted light observation. Automatic control of optical component exchange, top lens swing out and aperture iris diaphragm.



Light adjustment buttons



Stage adjustment buttons



■ **Lamp preset and lamp on/off button**
Mounted on the front left side of the microscope frame.

■ **Fine/coarse and stage escape button**
Mounted on the left side of the microscope frame.

■ **Hand switch/U-HSTR2**
Hand set used to control the microscope while conducting visual observations.

■ **Control box/BX-UCB**
Motorized modules attached to the microscope are controlled via this control box, which is linked to the computer via an RS232C connector.



EYEPIECES



Eyepieces/WHN, WH, SWH
Eyepieces maintain image flatness even when a reflected light illuminator or other intermediate tube is attached. The two available types are F.N. 22 and F.N. 26.5.

Eyepiece specifications

Item	Name	F.N.	Diopter	Micrometer (omm)
Widefield	WHN10X	22		24
	WHN10X-H	22	-8 — +5	24
	WH15X	14		24
	CROSSWHN10X	22	-8 — +5	
Super widefield	SWH10X-H	26.5	-8 — +2	—
	MICROSSWH10X	26.5	-8 — +2	
	CROSSSWH10X	26.5	-8 — +2	

* Users who want the SWH10X micrometer: please have your eyepiece adapted by the manufacturer.

OBSERVATION TUBES/EYEPOINT ADJUSTER

A wide range of observation tubes is available for the BX2 series, including wide field binocular and trinocular types, various tilting tubes, and tubes for observation of upright images in which the specimen and the observed image move in the same direction.



- ① Super widefield erect image trinocular tube/U-SWETR
- ② Super widefield trinocular tube/U-SWTR-3
- ③ Trinocular tube/U-TR30-2
- ④ Trinocular tube/U-TR30NIR
- ⑤ Binocular tube/U-BI30-2
- ⑥ Tilting binocular tube/U-TBI-3
- ⑦ Ergonomic binocular tube/U-ETBI
- ⑧ Ergonomic binocular tube/U-TTBI
- ⑨ Eyepoint adjuster/U-EPA2

CONDENSERS

Universal condensers, ultra low magnification condensers and Abbe type condensers are available to meet all observation needs.



8 position universal condenser/U-UCD8
Top lenses/U-TLD, U-TLO



Brightfield condensers



Darkfield condensers



Phase/darkfield condenser/U-PCD2



Polarizing condenser U-POC-2

STAGES

The U-SHG and U-SHGT rubber grip can be attached to the standard stage handle. Different specimen holders are available for use with one glass slide or two, making it easy to switch specimens with just one hand. A simple plain stage is available with optional stage clips. Rotatable stages are available with the option of simple stage clips or attachable mechanical stage mechanisms. A special grooved stage is available, designed to disperse immersion oil, preventing the glass slide from sticking to the stage surface. Users can choose according to purpose.



Mechanical stage with left-hand control/U-SVLB-4
Specimen holder/U-HRD-4
Rubber grip/U-SHG



Mechanical stage with right-hand control/U-SVRB-4
Specimen holder/U-HLD-4
Rubber grip/U-SHG



Oil rectangular stage with right-hand control/U-SVRO
Oil rectangular stage with left-hand control/U-SVLO
Specimen holder/U-HLD-4, Rubber grip/U-SHG



Plain stage/U-SP

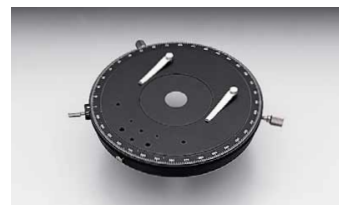

Rotatable graduated stage/U-SRG2



Precision rotatable graduated stage/U-SRP,
Mechanical stage/U-FMP

REVOLVING NOSEPIECES



Septuple revolving nosepiece for DIC/simple POL/
U-D7RE

Septuple revolving nosepiece with slider slot for DIC/POL. Use of thick specimen holder may damage some objectives.



Centerable sextuple revolving nosepiece/
U-P6RE

Sextuple centerable revolving nosepiece allows centering of three objectives. Use of thick specimen holder may damage some objectives.

GROUP OBSERVATION SYSTEMS

Multi observation bodies/BX2N-DO, BX2N-SDO, BX2N-MDO-5, BX2N-MDO-10

Olympus discussion systems are invaluable for research studies, lab training, and education. Multi-view configurations are available to accommodate between 2 and 10 participants. The pointer is powered by LED, so there is no need for concern about sudden lamp failure.



INTERMEDIATE UNITS



Dual port/U-DP
The dual port may be used for a variety of purposes: separating the image by spectral composition (e.g. directing fluorescence to one port, infrared to the other), as an illumination port for adding a new incident light source or as a C-mount compatible trinocular port for image output. A 1X image formation lens is also provided.



Trinocular intermediate attachments/U-TRU
This intermediate trinocular attachment can be used simultaneously with the inclinable binocular observation tube (U-TBI-3). Two light paths are selectable: 100% light for binocular observation or 20% for binocular observation and 80% for imaging through the trinocular port.



Drawing attachment/U-DA
The drawing attachment projects an image of the pencil and drawing surface into the visual field. Tracing of microscopic structures is made easier and more accurate.



Simple polarizing attachment
Simple polarizing observation can be accomplished with the combination of U-KPA intermediate attachment for simple polarizing observation, U-ANT analyzer for transmitted light and U-POT polarizer.



Magnification changer/U-CA
This intermediate magnification changer expands the capability of UIS2 objectives, optimizing the imaged field without the interruption of rotating the objective lens: 1X / 1.25X / 1.6X / 2X



Magnification changer/U-ECA, U-ECA1.6X
This intermediate magnification changer expands the capability of UIS2 objectives, optimizing the imaged field without the interruption of rotating the objective lens: U-ECA: 1X / 2X, U-ECA1.6X: 1X / 1.6X



Arrow pointer/U-APT
Enables insertion of a red or green LED arrow for display on a monitor.



Filter cassette/U-FC
Use of this cassette enables fast exchange among three filters (with ø45 mm and below 2.8 mm thickness).

CAMERA ADAPTERS

The single port tube of the trinocular tube is detachable, and can be used with various cameras via a range of adapters. Using the U-TV1X-2, video can be shot directly with no need for a shooting lens. The potential of your microscope is greatly increased by its multiple image utilization capabilities.



- ①U-SMAD
- ②U-CMAD3
- ③U-TMAD
- ④U-BMAD
- ⑤U-FMT
- ⑥U-TV0.25x-C
- ⑦U-TVZ
- ⑧U-TV0.35x-C-2
- ⑨U-TV0.5x-C-3
- ⑩U-TV0.63x-C
- ⑪U-TV1x-2

BX51/61 specifications

		BX51	BX61
Microscope frame	Optical system	UIS2 optical system	
	Focus	Vertical stage movement: 25 mm Stage stroke with coarse adjustment limit stopper Torque adjustment for coarse adjustment knobs Stage mounting position variable High sensitivity fine focusing knob (minimum adjustment gradations: 1 μm)	Motorized focus/vertical stage movement: 25 mm, 0.01 μm increments, maximum speed: 3 mm/s, coarse/fine changeover button, stage shunting button and stage up/down button
	Illuminator	Built-in Koehler illumination for transmitted light 12 V 100 W halogen bulb Light intensity LED indicator Built-in filters (LBD-IF, ND6, ND25, option)	Light preset switch
Revolving nosepiece		Interchangeable reversed quintuple/sextuple/septuple nosepiece Motorized sextuple revolving nosepiece with slider slot for DIC Septuple revolving nosepiece for DIC/simple POL	
Observation tube	Widefield (F.N. 22)	<ul style="list-style-type: none"> Widefield binocular, inclined 30° Widefield tilting binocular, inclined 5°-35° Widefield trinocular, inclined 30° Widefield tilting/telescoping binocular, inclined 0°-25°, telescoping 0-45 mm 	
	Super widefield (F.N. 26.5)	Super widefield trinocular, inclined 24°	
Stage		Ceramic-coated coaxial stage with left or right hand low drive control: with rotating mechanism and torque adjustment mechanism, optional rubber grips available (Non stick grooved coaxial, plain, rotatable stages are also available)	
Condenser		<ul style="list-style-type: none"> Abbe (N.A. 1.1), for 4x-100x Swing out Achromatic (N.A. 0.9), for 1.25x-100x (swing-out: 1.25x-4x) Achromatic Aplanatic (N.A. 1.4), for 10x-100x Universal (N.A. 1.4/0.9), for 2x-100x (swing-out: 2x-4x, with oil top lens: 20x-100x) 	
Motorized fluorescence illuminator ^{*3}		Motorized reflected fluorescence, 6-position mirror turret unit, motorized shutter changeover speed: shutter speed: 0.1 s	
Motorized universal condenser ^{*3}		8-position with motorized AS, turret and top lens swing out mechanism (N.A. 1.4-0.9), for 1.25x ^{*1,2} -100x	
Motorized transmitted filter wheel ^{*3}		To be mounted on light exit, 6 positions, ø32, filter thickness: up to 6 mm	
Motorized reflected filter wheel ^{*3}		To be mounted between the lamphouse and the frame, 6 positions, ø25/ø32, filter thickness: up to 6 mm	
Motorized observation filter wheel ^{*3}		To be mounted between the frame and the observation tube, 6 positions, ø25/ø32, filter thickness: up to 6 mm	
Hand switch ^{*3}		Control of septuple revolving nosepiece, 6-position mirror turret illumination unit and 8-position condenser	
Control box ^{*3}		Serial interface RS232C, built-in transmitted/reflected halogen power supply	

^{*1} Slight vignetting may occur in the periphery of the field due to the top lens. This occurs in observation only. ^{*2} U-FWCO 1.25x should be mounted on U-FWT ^{*3} Optional

BX51 dimensions

(unit: mm)

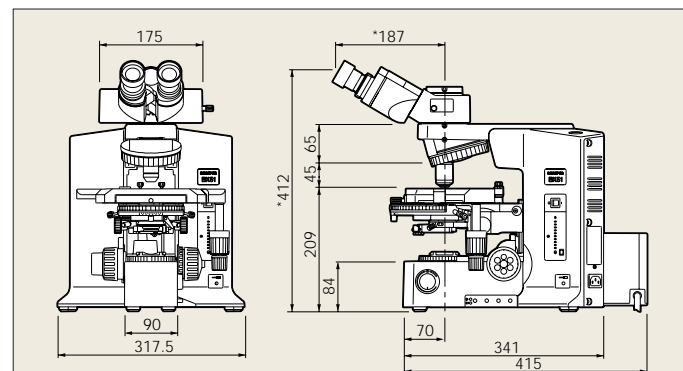

Weight: 18 kg Power consumption: 140 W
The length marked with an asterisk (*) may vary according to interpupillary distance.
Distance for figure shown is 62 mm.

BX51+BX-RFA dimensions

(unit: mm)

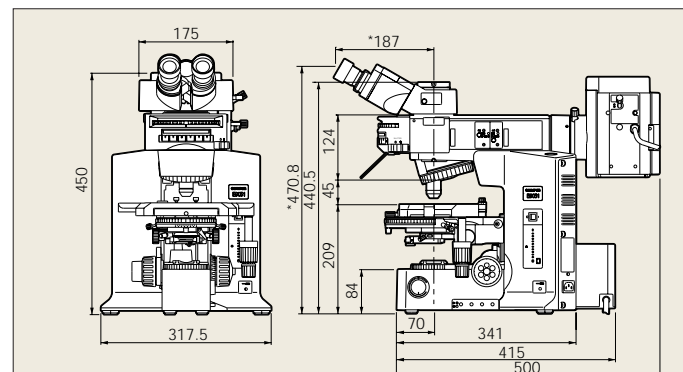

Weight: 27 kg Power consumption: 390 W
The length marked with an asterisk (*) may vary according to interpupillary distance.
Distance for figure shown is 62 mm.

BX51+U-DO3 dimensions

(unit: mm)

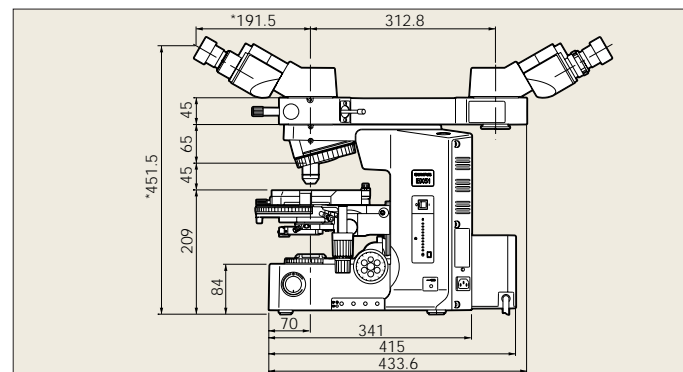

Weight: 20.5 kg Power consumption: 160 W
The length marked with an asterisk (*) may vary according to interpupillary distance.
Distance for figure shown is 62 mm.

BX51+U-MDO10 dimensions

(unit: mm)

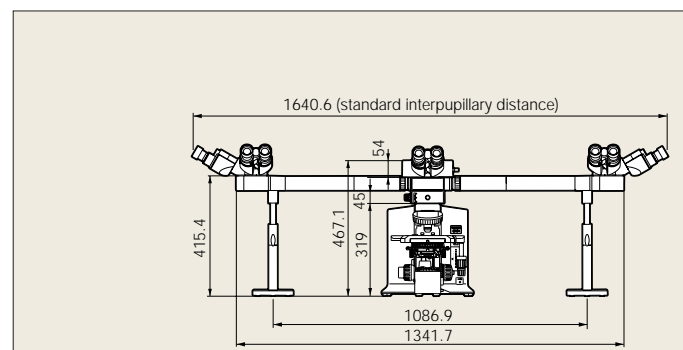

Weight: 45 kg Power consumption: 160 W

BX61 dimensions

(unit: mm)

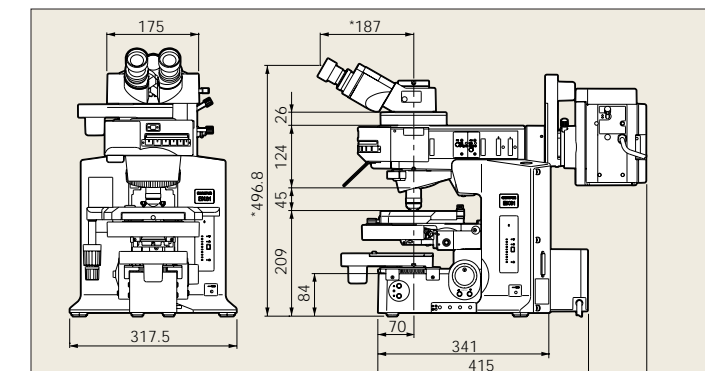

Weight: 37 kg Power consumption: 500 W
The length marked with an asterisk (*) may vary according to interpupillary distance.
Distance for figure shown is 62 mm.

BX-UCB dimensions

(unit: mm)

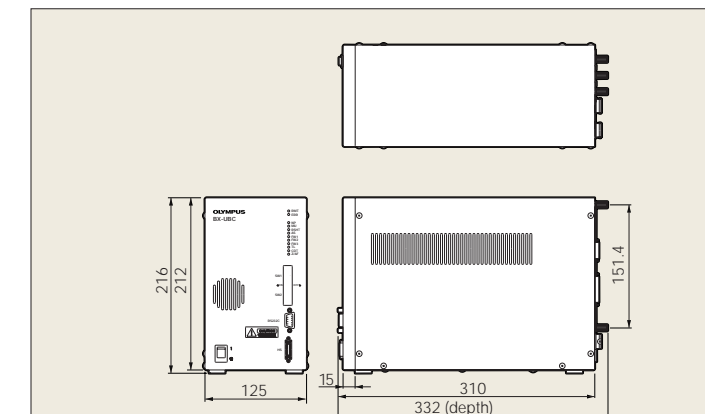

Weight: 5 kg Power consumption: 250 W

U-HSTR2 dimensions

(unit: mm)

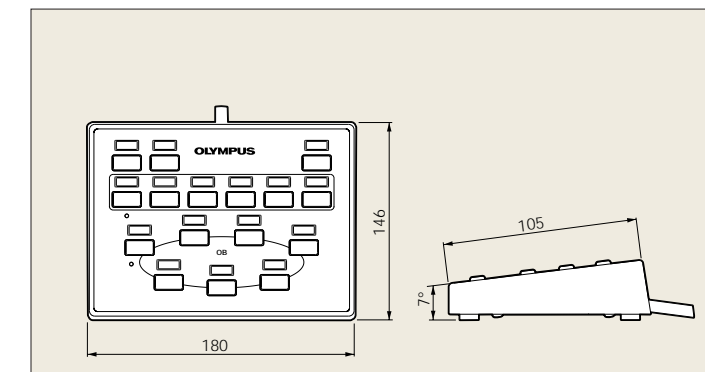

Weight: 0.4 kg

